

Board Office Use: <b>Legislative File Info.</b>	
File ID Number	23-1217
Introduction Date	6/7/2023
Enactment Number	23-1070
Enactment Date	6/7/2023 er



# Board Cover Memorandum

<b>To</b>	Board of Education
<b>From</b>	Kyla Johnson-Trammell, Superintendent Lisa Grant-Dawson, Chief Business Officer Hannah Press
<b>Meeting Date</b>	June 7, 2023
<b>Subject</b>	Approval of the Resolution for the Intent to Dedicate a Public Utility Easement to the Pacific Gas and Electric Company (“PG&E”) for the District’s Participation in PG&E’s Electric Vehicle Charge Schools and Parks Program

**Ask of the Board** Adoption by the Board of Education of Resolution No. 2223-0218, which will establish the District’s intent to dedicate an easement to PG&E to allow PG&E to access East Oakland Pride Elementary School (“Site”) to install and maintain the components of the electrical vehicle chargers PG&E is providing as part of the District’s participation in PG&E’s program to provide electric vehicle charging infrastructure at school facilities (i.e., PG&E’s Electric Vehicle Charge Schools and Parks Program, herein after the “Program”).

**Background** The Site was selected to participate in PG&E’s program to provide electric vehicle charging infrastructure at school facilities, which will allow the District to install three electric chargers at the Site. To secure the Site’s participation in the Program, the District signed an Agreement with PG&E on March 24, 2022, pursuant to delegated authority. (BP 3312; Education Code §17604.) The Board’s Ratification of the Agreement with PG&E is before the Board for approval at this meeting. The Board’s Ratification of the Agreement with PG&E was approved on April 12th, 2023. Pursuant to the Agreement, PG&E has requested that the District convey an easement to PG&E to allow PG&E to access the Site to install and maintain the components of the electric vehicle chargers PG&E will be providing under the Agreement (i.e., the Electric Vehicle Service Connection and the Electric Vehicle Supply Infrastructure). In order to convey the easement to PG&E the District must follow the following process:

Step 1: Adopt a resolution by 2/3 vote, declaring the Board’s intention to dedicate or convey the easement to PG&E. The resolution must fix a time not less than 10 days thereafter for a public hearing at a regular Board meeting. (Ed. Code, § 17557.)

Step 2: After the resolution in Step 1 is adopted, post the required notices as follows: 1) post a copy of the adopted resolution in three public places in the

District not less than 10 days prior to the public hearing regarding the proposed dedication, and 2) publish notice in a newspaper published in the District at least 5 days prior to the meeting at which the public hearing will be held. (Ed. Code, § 17558.)

Step 3: Hold the public hearing and adopt a second resolution by 2/3 vote authorizing execution of the easement deed. (Ed. Code, § 17559.)

**Discussion** See Resolution No. 2223-0218 - East Oakland Pride Elementary School (“Site”) to install and maintain the components of the electrical vehicle chargers PG&E is providing as part of the District’s participation in PG&E’s program to provide electric vehicle charging infrastructure at school facilities (i.e., PG&E’s Electric Vehicle Charge Schools and Parks Program, herein after the “Program”).

**Fiscal Impact** N/A

**Attachment(s)**

- Resolution No. 2223-0218 - Intent to Dedicate a Public Utility Easement to the Pacific Gas and Electric Company (“PG&E”) for the District’s Participation in PG&E’s Electric Vehicle Charge Schools and Parks Program
- EV Easement Document (Exhibit A)
- OUSD/PG&E Project Contract (Exhibit B)

**RESOLUTION OF  
THE BOARD OF EDUCATION OF THE  
OAKLAND UNIFIED SCHOOL DISTRICT**

**RESOLUTION NO. 2223-0218**

**RESOLUTION OF INTENT TO DEDICATE PUBLIC UTILITY EASEMENT TO THE  
PACIFIC GAS AND ELECTRIC COMPANY FOR THE DISTRICT'S PARTICIPATION  
IN THE PACIFIC GAS AND ELECTRIC COMPANY'S ELECTRICAL VEHICLE  
CHARGE SCHOOLS AND PARKS PROGRAM**

**WHEREAS**, the Oakland Unified School District ("District") owns certain real property located at 8000 Birch Street, Oakland, California, 94621, currently designated as Assessor's Parcel Numbers 40-3370-1-4 and 40-3371-1-2, and as more particularly described in in the Easement Deed, attached hereto and incorporated herein as **Exhibit A** to this Resolution ("Easement Deed"), on which the property is currently improved with East Oakland Pride Elementary School ("Site");

**WHEREAS**, the Pacific Gas and Electric Company ("PG&E") is a California Corporation;

**WHEREAS**, the Site was selected by PG&E to join PG&E's Electric Vehicle Charge Schools and Parks Program ("Program");

**WHEREAS**, the purpose of the Program is to provide electrical vehicle charging infrastructure at school facilities and education institutions;

**WHEREAS**, the District and PG&E signed an Agreement on March 24, 2023, and March 25, 2022, respectively, ("Agreement"), to secure the District's participation in the Program, a copy of which is attached hereto and incorporated herein as **Exhibit B** to this Resolution;

**WHEREAS**, as part of the District's participation in the Program, three electric vehicle chargers will be installed at the Site and the District has selected ChargePoint as its supplier through the Program, who will provide the equipment and subscription services for the electric vehicle chargers that will be installed;

**WHEREAS**, as part of the District's participation in the Program, PG&E will design, construct, own, and maintain some components for the electric vehicle chargers, i.e., the Electric Vehicle Service Connection and the Electric Vehicle Supply Infrastructure, at no cost to the District;

**WHEREAS**, as part of the District's participation in the Program, PG&E will provide the District with a rebate, currently estimated at \$39,315.00 pursuant to the Agreement, to go toward the total cost incurred by the District for participating in the Program;

**WHEREAS**, pursuant to the Agreement, PG&E has requested that the District convey an easement to PG&E to allow PG&E access to the Site to install and maintain the Electric Vehicle Service Connection and the Electric Vehicle Supply Infrastructure that PG&E is providing to the District as part of the District's participation in the Program;

**WHEREAS**, the easement conveyed to PG&E is intended to allow PG&E to construct, reconstruct, replace, remove, maintain, inspect, and use facilities, to install and maintain the Electric Vehicle Service Connection and the Electric Vehicle Supply Infrastructure and all equipment necessary for the distribution of electric energy and communication purposes, as described in the Easement Deed attached hereto as **Exhibit A**, together with a right of way therefor, on, over, and under that certain land described and depicted as part of the Easement Deed attached hereto as **Exhibit A**;

**WHEREAS**, Education Code section 17556 provides that the governing board may dedicate or convey to any public corporation, or private corporation engaged in the public utility business, without a vote of the electors first being taken, an easement to lay, construct, reconstruct, maintain, and operate water, sewer, gas, or storm drain pipes or ditches, electric or telephone lines, and access roads used in connection therewith, over and upon any land belonging to the District, upon such terms and conditions as the parties thereto may agree; and

**WHEREAS**, pursuant to Education Code section 17557, before so conveying property, the governing board must adopt a resolution in an open meeting by a two-thirds vote of all of its members declaring the intention to convey the property.

**NOW, THEREFORE**, the Oakland Unified Board of Education the hereby finds, determines, declares, orders, and resolves as follows:

1. Recitals. The foregoing recitals are hereby adopted as true and correct.
2. Intent to Dedicate, Terms, and Conditions. Pursuant to Education Code sections 17556 *et seq.*, it is the intention of the District to convey the Easement Deed pursuant to the terms and conditions set forth in the Grants of Easement attached hereto as **Exhibit A**.
3. Public Hearing. On the 21st day of June 2023, at the hour of 7 p.m., or as soon thereafter as the matter can be heard, the Board of Education shall hold a public hearing upon the question of making the conveyance of the Easement Deed to PG&E pursuant to Education Code sections 17558 and 17559, at which time any interested person may appear and be heard thereon.
4. Notice of Adoption. Notice of adoption of this Resolution shall be given by posting a true copy of this Resolution in three (3) public places in the District not less than ten (10) days before the date of the public hearing described above. Notice of said public hearing shall be given by publishing the notice in a newspaper of general circulation published in the District or in a newspaper published in Alameda County that has general circulation within the District not less than five (5) days before the date of the public hearing described above.

Passed by the following vote:

PREFERENTIAL AYES: None

PREFERENTIAL NOES: None

YEA: Benjamin "Sam" Davis, Jennifer Brouhard, VanCedric Williams, Valarie Bachelor, Vice President Thompson, President Mike Hutchinson

NOES: None

ABSENT: Natalie Gallegos Chavez (Student Director), Linh Le (Student Director), (Vacancy)

ABSTAINED: None

RECUSED: None

We hereby certify that the foregoing is a full, true and correct copy of a Resolution adopted, at a Regular Meeting of the Governing Board of the Oakland Unified School District held on June 7, 2023.

Legislative File	
File ID Number:	23-1217
Introduction Date:	6-7-2023
Enactment Number:	23-1070
Enactment Date:	6/7/2023
By:	er

**OAKLAND UNIFIED SCHOOL DISTRICT**

 /6/8/2023  
Mike Hutchinson President, Board of Education

 /6/8/2023  
Kyla Johnson Trammell, Secretary, Board of Education

**EXHIBIT A**

Easement Deed between the District and PG&E

**RECORDING REQUESTED BY AND RETURN TO:**

**PACIFIC GAS AND ELECTRIC COMPANY**  
**245 Market Street, N10A, Room 1015**  
**P.O. Box 770000**  
**San Francisco, California 94177**

Location: City/~~Union~~ Oakland

Recording Fee \$ \_\_\_\_\_

Document Transfer Tax \$ 0.00

- This is a conveyance where the consideration and Value is less than \$100.00 (R&T 11911)
- Computed on Full Value of Property Conveyed, or
- Computed on Full Value Less Liens & Encumbrances Remaining at Time of Sale
- Exempt from the fee per GC 27388.1 (a) (2); This document is subject to Documentary Transfer Tax

(SPACE ABOVE FOR RECORDER'S USE ONLY)

\_\_\_\_\_  
Signature of declarant or agent determining tax

**LD# 2302-03-**

**EASEMENT DEED**

PM#, 0070 - ZIS 8000 BIRCH ST OAKLAND

OAKLAND UNIFIED SCHOOL DISTRICT, who acquired title as Oakland School District of Alameda County, a public school district,

hereinafter called Grantor, hereby grants to PACIFIC GAS AND ELECTRIC COMPANY, a California corporation, hereinafter called Grantee, the right from time to time to construct, reconstruct, install, inspect, maintain, replace, remove, and use facilities of the type hereinafter specified, together with a right of way therefor, within the easement area as hereinafter set forth, and also ingress thereto and egress therefrom, over and across the lands of Grantor situate in the City of Oakland, County of Alameda, State of California, described as follows:

(APN 40-3370-1-4 & APN 40-3371-1-2)

The parcel of land described in the deed from Francisco Costa and Carolina Costa to Grantor dated August 17, 1920 and recorded in Book 2952 of Official Records at page 352, Alameda County Records.

The parcel of land described in the deed from S. D. Wilcox to Grantor dated August 5, 1920 and recorded in Book 2944 of Official Records at page 303, Alameda County Records.

The parcel of land described in the deed from Robert D. Elliot and Mary B. Elliot to Grantor dated September 12, 1965 and recorded in Book 1613 of Official Records at page 781, Alameda County Records.

The parcel of land described in the deed from Robert Elliot and Elizabeth K. Elliot to Grantor dated August 9, 1920 and recorded in Book 2981 of Official Records at page 45, Alameda County Records.

Said facilities and easement area are described as follows:

Such underground conduits, pipes, manholes, service boxes, wires, cables, and electrical conductors; aboveground marker posts, risers, and service pedestals; underground and aboveground switches, fuses, terminals, and transformers with associated concrete pads; electric vehicle charging supply equipment, bollards and/or curbs or other associated safety equipment, associated signage; and fixtures and appurtenances necessary to any and all thereof, as Grantee deems necessary for the distribution of electric energy and communication purposes located within the strips of land of the uniform width of 10 feet, lying 5 feet on each side of the alignment of the facilities as initially installed hereunder. The approximate location of said facilities are shown upon Grantee's Drawing Number 31600716 attached hereto and made a part hereof.

Grantee agrees that on receiving a request in writing, it will at Grantor's expense, survey, prepare and record a "Notice of Final Description" referring to this instrument and setting forth a description of said strips of land.

Grantor further grants to Grantee the right, from time to time, to trim or to cut down any and all trees and brush now or hereafter within said easement area, and shall have the further right, from time to time, to trim and cut down trees and brush along each side of said easement area which now or hereafter in the opinion of Grantee may interfere with or be a hazard to the facilities installed hereunder, or as Grantee deems necessary to comply with applicable state or federal regulations.

Grantor shall not erect or construct any building or other structure or drill or operate any well within said easement area.

Grantor further grants to Grantee the right to assign to another public utility as defined in Section 216 of the California Public Utilities Code the right to install, inspect, maintain, replace, remove and use communications facilities within said easement area (including ingress thereto and egress therefrom).

In the event upon termination of the electric vehicle charging station contract as set forth in said terms and conditions, Grantee shall upon written demand therefor execute and deliver to Grantor a good and sufficient quitclaim of said easement and right of way or such portion thereof conveyed in this document, at Grantor's expense.

The legal description herein, or the map attached hereto, defining the location of this utility distribution easement, was prepared by Grantee pursuant to Section 8730 (c) of the Business and Professions Code.

The provisions hereof shall inure to the benefit of and bind the successors and assigns of the respective parties hereto.



In exercising its easement rights hereunder, Grantee shall not unreasonably interfere with, disrupt, or materially adversely affect Grantor's business operations or access rights at the property owned by Grantor.

Dated: \_\_\_\_\_, \_\_\_\_\_.

I hereby certify that the foregoing is a full, true and correct copy of a Resolution adopted, at a Regular Meeting of the Governing Board of the Oakland Unified School District held on June 7, 2023.

I hereby certify that a resolution was adopted on the \_\_\_\_ day of \_\_\_\_\_, 20\_\_\_\_, by the \_\_\_\_\_ authorizing the foregoing grant of easement.  
By \_\_\_\_\_

OAKLAND UNIFIED SCHOOL DISTRICT

\_\_\_\_\_  
Mike Hutchinson

President, Board of Education

\_\_\_\_\_  
Kyla Johnson-Trammell

Superintendent and Secretary, Board of Education

A notary public or other officer completing this certificate verifies only the identity of the individual who signed the document to which this certificate is attached, and not the truthfulness, accuracy, or validity of that document.

State of California  
County of \_\_\_\_\_ )

On \_\_\_\_\_, before me, \_\_\_\_\_,  
Here insert name and title of the officer  
personally appeared \_\_\_\_\_  
\_\_\_\_\_

who proved to me on the basis of satisfactory evidence to be the person(s) whose name(s) is/are subscribed to the within instrument and acknowledged to me that he/she/they executed the same in his/her/their authorized capacity(ies), and that by his/her/their signature(s) on the instrument the person(s), or the entity upon behalf of which the person(s) acted, executed the instrument.

I certify under PENALTY OF PERJURY under the laws of the State of California that the foregoing paragraph is true and correct.

WITNESS my hand and official seal.

\_\_\_\_\_  
Signature of Notary Public (Seal)

**CAPACITY CLAIMED BY SIGNER**

- Individual(s) signing for oneself/themselves
- Corporate Officer(s) of the above named corporation(s)
- Trustee(s) of the above named Trust(s)
- Partner(s) of the above named Partnership(s)
- Attorney(s)-in-Fact of the above named Principal(s)
- Other \_\_\_\_\_

**LEGEND**

- ELECTRIC FACILITIES
- SUBJECT PARCEL
- M ELECTRIC METER
- TF ELECTRIC TRANSFORMER
- — — — CENTERLINE OF ALIGNMENT OF FACILITIES
- A.C.R. ALAMEDA COUNTY RECORDS

REAL PROPERTY SITUATED  
IN THE S.E./4 OF N.E./4  
OF SECTION 15  
RANCHO SAN ANTONIO (Y. PERALTA)

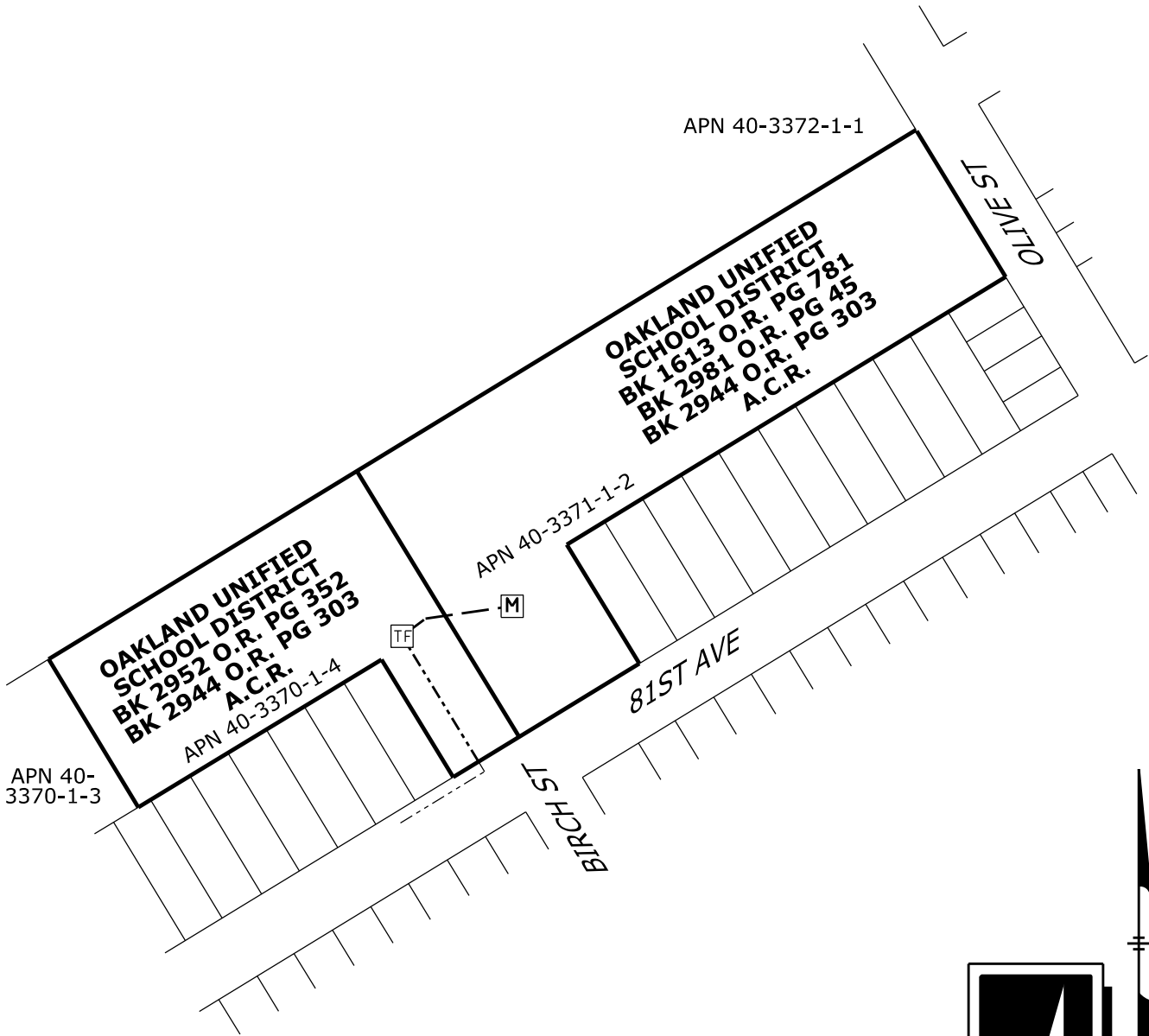

UNLESS OTHERWISE SHOWN ALL COURSES EXTEND TO OR ALONG ALL BOUNDARIES OR LINES

<b>APPLICANT: OAKLAND UNIFIED SCHOOL DISTRICT</b>				SCALE: N/A		DATE: 07/14/22	
<b>8000 BIRCH ST, OAKLAND CA 94621</b>							
SECTION: (15)	TOWNSHIP: (02S)	RANGE: (03W)	MERIDIAN: MDBM	COUNTY OF: ALAMEDA		CITY OF: OAKLAND	
				F.B.: N/A	DR.BY: LC	CH.BY: PRFB	
PLAT MAP: H0703 (E) PG&E L.D. REFERENCES: N/A				<b>EAST BAY DIVISION</b>		31600716 AUTHORIZ.	<b>31600716</b> <b>DRAWING No.</b>

Attach to LD: 2302-03-  
Area, Region or Location: 2; East Bay Division  
Land Service Office: Fresno  
Line of Business: Electric Charging Station (95), Electric Distribution (43)  
Business Doc Type: Easements  
MTRSQ: 23.02.03.15.13, 23.02.03.15.12  
FERC License Number: N/A  
PG&E Drawing Number: 31601716  
Plat No.: H0703  
LD of Affected Documents: N/A  
LD of Cross-Referenced Documents: N/A  
Type of interest: Communication Easements (6), Electric Underground Easements (4), Utility  
Easement (86)  
SBE Parcel: N/A  
% Being Quitclaimed: N/A  
Order or PM: 31601716  
JCN: N/A  
County: Alameda  
Utility Notice Number: N/A  
851 Approval Application No: N/A; Decision: N/A  
Prepared By: LC  
Checked By: PRFB

**EXHIBIT B**

Agreement Between the District and PG&E, signed by the District on March 24, 2022, and signed by PG&E on March 25, 2022

Board Office Use: Legislative File Info.	
File ID Number	23-0286
Introduction Date	4-12-2023
Enactment Number	23-0658
Enactment Date	4-12-2023 er



**OAKLAND UNIFIED SCHOOL DISTRICT**  
Community Schools, Thriving Students

## Memo

**To** Board of Education

**From** Kyla Johnson-Trammell, Superintendent  
Tadashi Nakadegawa, Division of Facilities Planning and Management

**Board Meeting Date** April 12, 2023

**Subject** Parks and Recreational Contract Agreement – Pacific Gas & Electric Company - East Oakland Pride Elementary School Electrical Vehicle Charger Installation Project – Division of Facilities Planning and Management

**Action Requested** Ratification by the Board of Education of the Agreement between the District and the Pacific Gas & Electric Company (“PG&E”) for the District’s participation in **PG&E’s Electric Vehicle Charge Schools and Parks Program, (“Program”)**, which will provide three electric vehicle chargers to be installed at . Through this Agreement, PG&E will design, construct, own, and maintain some components for the electric vehicle chargers, namely, the Electric Vehicle Service Connection and the Electric Vehicle Supply Infrastructure, at no cost to the District. The District will contract directly with the District’s electric vehicle supply equipment package supplier (ChargePoint) for the equipment and software for the electric vehicle chargers. The District will contract with another entity for the installation and activation of the electric vehicle chargers. As part of the District’s participation in the Program, the District will receive a rebate from PG&E, currently estimated at \$39,315.00, pursuant to the Agreement, to go toward the total cost incurred by the District for participating in the Program. After the electric vehicle chargers become operational, the District will pay PG&E monthly for the electricity supplied to the electric vehicle chargers, which the District currently estimates to be a total of approximately \$98,304.00 (approximately \$1,024/month) over the 8-year term. The contract with PG&E will expire 8 years from the date the electric vehicle chargers become operational, which is expected to be approximately December 31, 2031, pursuant to the Agreement.

**Discussion** To secure the Site’s participation in the Program, the Deputy Chief of Facilities Planning and Management signed the Agreement with PG&E on March 24, 2022, thus requiring Board ratification of the Agreement with PG&E. (BP 3312; Education Code §17604.)

**LBP (Local Business Participation Percentage)** 0.00%

**Recommendation** Ratification by the Board of Education of the Agreement between the District and the Pacific Gas & Electric Company (“PG&E”) for the District’s participation in **PG&E’s Electric Vehicle Charge Schools and Parks Program, (“Program”)**, which will provide three electric vehicle chargers to be installed at East Oakland Pride Elementary School. Through this Agreement, PG&E will design, construct, own, and maintain some components for the electric vehicle chargers, namely, the Electric Vehicle Service Connection and the Electric Vehicle Supply Infrastructure, at no cost to the District. The District will contract directly with the District’s electric vehicle supply equipment package supplier (ChargePoint) for the equipment and software for the electric vehicle chargers. The District will contract with another entity for the installation and activation of the

electric vehicle chargers. As part of the District's participation in the Program, the District will receive a rebate from PG&E, currently estimated at \$39,315.00, pursuant to the Agreement, to go toward the total cost incurred by the District for participating in the Program. After the electric vehicle chargers become operational, the District will pay PG&E monthly for the electricity supplied to the electric vehicle chargers, which the District currently estimates to be a total of approximately \$98,304.00 (approximately \$1,024/month) over the 8-year term. The contract with PG&E will expire 8 years from the date the electric vehicle chargers become operational, which is expected to be approximately December 31, 2031, pursuant to the Agreement.

**Fiscal Impact**

Fund 21 Building Funds, Measure Y

**Attachments**

- Contract Justification Form
- Parks and Recreational Contract w/ PG&E
- Routing Form



**CONTRACT JUSTIFICATION FORM**

**This Form Shall Be Submitted to the Board Office With Every Agenda Contract.**

**Legislative File ID No.** 23-0286

**Department:** Facilities Planning and Management

**Vendor Name:** Pacific Gas & Electric Company

**Project Name:** East Oakland Pride Elementary School  
Electrical Vehicle Charger Installation

**Project No.:** 23103

**Contract Term:** Intended Start: 3-24-2022

**Intended End:** 12-31-2031

**Total Cost Over Contract Term:** \$98,304.00

**Approved by:** Tadashi Nakadegawa

**Is Vendor a local Oakland Business or has it met the requirements of the**

**Local Business Policy?**  Yes (No if Unchecked)

**How was this contractor or vendor selected?**

The District was selected to participate in PG&E’s Electric Vehicle Charge Schools and Parks Program, which will provide for three electric vehicle chargers to be installed at East Oakland Pride Elementary School.

**Summarize the services or supplies this contractor or vendor will be providing.**

PG&E will assist the District with purchasing the equipment and software for the chargers through the District’s package supplier (ChargePoint). PG&E will also design, construct, own, and maintain some components of the electric vehicle chargers, namely, the Electric Vehicle Service Connection and the Electric Vehicle Supply Infrastructure. After the electric vehicle chargers become operational, the District will pay PG&E monthly for the electricity supplied to the electric vehicle chargers.

**Was this contract competitively bid?**  Check box for “Yes” (If “No,” leave box unchecked)

If “No,” please answer the following questions:

1) How did you determine the price is competitive?

PG&E will be providing some infrastructure components for the electric vehicle chargers at no cost to the District and will provide the District with a rebate in the estimated amount of \$39,315.00 to go towards the total cost the District incurs to participate in the program. After the chargers become operation, the District will pay PG&E monthly for the electricity used by the chargers. The District currently estimates that the total cost for electricity for the chargers over the 8-year term will be approximately \$98,304.00 (approximately \$1,024/month). This price is reasonable because PG&E will charge \$1.24/kW, which is the standard amount for a low use workplace for electricity for electric chargers.



2) Please check the competitive bidding exception relied upon:

Construction Contract:

- Price is at or under UPCCAA threshold of \$60,000 (as of 1/1/19)
- CMAS contract [may only include “incidental work or service”] (Public Contract Code §§10101(a) and 10298(a)) – *contact legal counsel to discuss if applicable*
- Emergency contract (Public Contract Code §§22035 and 22050) – *contact legal counsel to discuss if applicable*
- No advantage to bidding (including sole source) – *contact legal counsel to discuss if applicable*
- Completion contract – *contact legal counsel to discuss if applicable*
- Lease-leaseback contract RFP process – *contact legal counsel to discuss if applicable*
- Design-build contract RFQ/RFP process – *contact legal counsel to discuss if applicable*
- Energy service contract – *contact legal counsel to discuss if applicable*
- Other: \_\_\_\_\_ – *contact legal counsel to discuss if applicable*

Consultant Contract:

- Architect, engineer, construction project manager, land surveyor, or environmental services – selected (a) based on demonstrated competence and professional qualifications (Government Code §4526), **and** (b) using a fair, competitive RFP selection process (Government Code §§4529.10 et seq.)
- Architect or engineer *when state funds being used* – selected (a) based on demonstrated competence and professional qualifications (Government Code §4526), (b) using a fair, competitive RFP selection process (Government Code §§4529.10 et seq.), **and** (c) using a competitive process consistent with Government Code §§4526-4528 (Education Code §17070.50)
- Other professional or specially trained services or advice – no bidding or RFP required (Public Contract Code §20111(d) and Government Code §53060) – *contact legal counsel to discuss if applicable*
- For services other than above, the cost of services is \$109,300 or less (as of 1/1/23)
- No advantage to bidding (including sole source) – *contact legal counsel to discuss if applicable*

Purchasing Contract:

- Price is at or under bid threshold of \$109,300 (as of 1/1/23)
- Certain instructional materials (Public Contract Code §20118.3)
- Data processing systems and supporting software – choose one of three lowest bidders (Public Contract Code §20118.1)

- Electronic equipment – competitive negotiation (Public Contract Code §20118.2) – *contact legal counsel to discuss if applicable*
- CMAS contract [may only include “incidental work or service”] (Public Contract Code §§10101(a) and 10298(a)) – *contact legal counsel to discuss if applicable*
- Piggyback contract for purchase of personal property (Public Contract Code §20118) – *contact legal counsel to discuss if applicable*
- Supplies for emergency construction contract (Public Contract Code §§22035 and 22050) – *contact legal counsel to discuss if applicable*
- No advantage to bidding (including sole source) – *contact legal counsel to discuss if applicable*
- Other:   Purchase Agreement

Maintenance Contract:

- Price is at or under bid threshold of \$109,300 (as of 1/1/23)
- No advantage to bidding (including sole source) – *contact legal counsel to discuss*
- Other: \_\_\_\_\_

3) Explain in detail the facts that support the applicability of the exception marked above:

- PG&E will assist in design and construction of electric vehicle chargers at East Oakland Pride Elementary.



Clean Energy Transportation  
Pacific Gas and Electric Company  
77 Beale Street  
San Francisco, CA 94105

Hannah Press  
955 High Street  
Oakland, CA 94601

February 22, 2022

**PG&E EV Charge Schools and Parks Program Contract**

Dear Hannah,

We are pleased to share that the site(s) listed below have been selected to join PG&E's EV Charge Schools and Parks program, pending satisfaction of the site-specific contingencies described in this letter. When we receive your countersigned copy of this letter, we will move these sites into the Design phase and begin the engineering, design, and construction.

The following items are included in this Contract package:

- Part A: Project Description
- Part B: Terms and Conditions
- Attachment 1: Preliminary site designs
- Attachment 2: Sample easement (final version to be completed and signed once the project design is finalized)

You have selected ChargePoint as your EVSE supplier. Your contacts at ChargePoint should remain your key points of contact related to any questions about the application process, charger procurement, installation, commissioning, activation, and ongoing operations and maintenance.

Please review all of the documents in this package carefully and let me know if you have any questions. The Project Description and the Terms and Conditions will, when signed on behalf of the Site Host, constitute a legally binding contract between the Site Host and PG&E.

After we receive your signed copy, we will introduce you to your PG&E Project Manager, who will lead you through the design and construction of the project.

Thank you for your participation in this exciting program! You are taking an important step to support California's ambitious climate and air quality goals, and we appreciate that you've elected to work with PG&E to install charging stations at your site.

Sincerely,

Yen Tran  
Customer Onboard Specialist – EV Charge Schools and Parks  
[Yen.Tran@pge.com](mailto:Yen.Tran@pge.com)

**Part A: Project Description**

<b>Program</b>	EV Charge Schools and Parks Program as described in California Public Utilities Commission, or "CPUC", Decision Number 19-11-017 issued November 13, 2019, and as administered by PG&E
<b>Site Host Name and Contact Information</b>	<i>Hannah Press</i> 955 High Street Oakland, CA 94601 <a href="mailto:hannah.press@ousd.org">hannah.press@ousd.org</a> (510) 409-2784
<b>Site Address(es) and EVSE Package(s)</b>	8000 Birch Street Oakland, CA 94621 3 ChargePoint CT 4000 (Dual Port)
<b>Is Site Host the owner or lessee of the Site?</b>	Owner
<b>EVSE Package Supplier</b>	ChargePoint
<b>EVSE Owner (billing customer of record for EVSE energy charges)</b>	<i>Hannah Press</i> 955 High Street Oakland, CA 94601 <a href="mailto:hannah.press@ousd.org">hannah.press@ousd.org</a> (510) 409-2784
<b>Type of Use</b>	Publicly available and/or private use
<b>Term</b>	8 years from the date the EVSE becomes operational
<b>Contingencies</b>	As described below
<b>Rebate (estimate only, if applicable)</b>	<b>\$39,315.00</b> Refer to Section 3 of the Terms and Conditions.

Capitalized terms are defined in Part B: Terms and Conditions.

**Project Overview:** Site Host has selected the charge package(s) described above for deployment at the above Sites. PG&E will design, construct, own and maintain an EV Service Connection and related EV Supply Infrastructure at those Sites. Site Host will contract directly with the EVSE Package Supplier to supply, install and provide operations and maintenance services for the EVSE Package(s).

**Contingencies:** Selection of sites for inclusion in the Program involves careful consideration of the project costs and total scope of work, including site conditions. A final decision to proceed with construction is dependent on satisfaction of the following contingencies. PG&E may remove a Site from the Program if any of these contingencies is not satisfied. If PG&E removes a Site then this Contract will be deemed terminated with respect to that Site but will continue in force for other Sites (if any) described in the Project Description.

- **Easements.** All required easements must be obtained from applicable landowners and third parties within 60 days of signing this Contract. Refer to section 10 of the Terms and Conditions for details on how easements will be addressed.
- **Make-ready costs.** PG&E reserves the right to remove a Site from the Program at the completion of the design and estimation stage if the estimated cost of EVSE Service Connection and EV Supply Infrastructure for that site, inclusive of easement costs ("**make ready costs**") materially exceeds projected costs.

**Timely Commencement of EVSE Service.** This project is being subsidized by PG&E and California ratepayers in the expectation that Site Host will complete the installation process and make the EVSE charge service available for use as described in the above Project Description in a timely and reasonable manner. If this is not achieved, then, except in the case of a termination due to failure of a contingency, PG&E reserves the right to recover the fees and costs incurred by PG&E and its contractors after the execution of this Contract with respect to the affected Site(s) including, but not limited to, design cost, site walk costs, site preparation and construction costs. Rebates, if applicable, will not be paid until after the EVSE service has commenced.

**Site Host Acceptance.** Site Host confirms its participation in the Program and agrees to be bound by this Contract, including Part B: Terms and Conditions. By signing this Contract, Site Host is committing to deploy the number of charging ports and charger locations specified above and in the attached preliminary design, subject to the contingencies noted herein. If Site Host is also the EVSE Owner, then Site Host is responsible for both Site Host and EVSE Owner's obligations under the Contract.

*If Site Host will not be the EVSE Owner, then both Site Host and the EVSE Owner must sign this Contract.*

**EVSE Owner Acceptance.** By signing this Contract EVSE Owner confirms its participation in the Program and agrees to be bound by this Contract, including Part B: Terms and Conditions. By signing this Contract, EVSE Owner is committing to deploy the number of charging ports and charger locations specified above and in the attached preliminary design, subject to the contingencies noted herein.

**Part B: Terms and Conditions**

**1. Program Definitions**

- 1.1 Disadvantaged Community (DAC) – Census tracts in PG&E’s electric service territory with a top quartile score according to California Environmental Protection Agency’s CalEnviroScreen 3.0, or current version.
- 1.2 EV Service Connection – Traditional utility infrastructure from the utility distribution system to the meter, which may include but is not limited to cable, conductors, conduit, transformers and associated substructures from the utility distribution system. Also referred to as “To the Meter” (TTM) infrastructure.
- 1.3 EV Supply Infrastructure – Infrastructure from the meter (but not including the meter) to the parking space, this may include an electrical panel, cable and conduit necessary to deliver power to the parking space, as well as any equipment mounting infrastructure (e.g., concrete pad, Unistrut, etc.). Also referred to as “Behind the Meter” (BTM) infrastructure.

**High level EV infrastructure configuration and terminology**

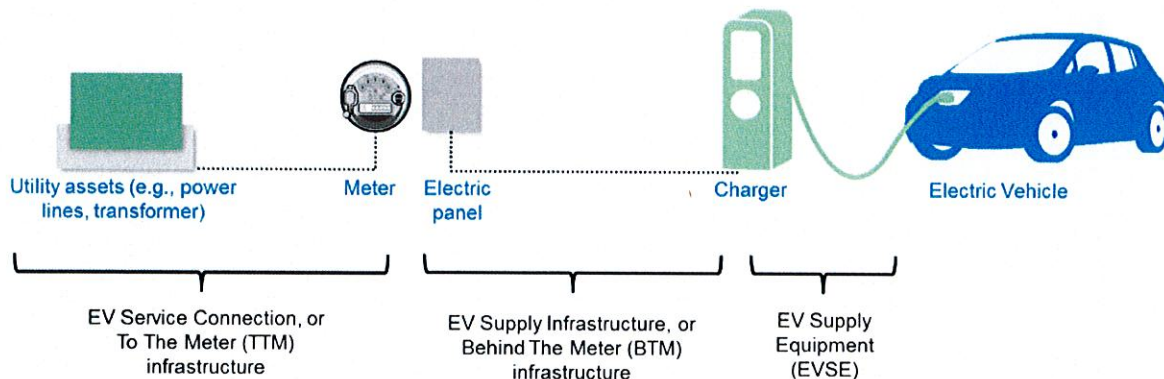

- 1.4 EVSE – Electric vehicle supply equipment used for charging EVs. This includes all components of the power dispenser(s) and power cabinet(s) including conductors (ungrounded, grounded, and equipment grounding conductors), the electric vehicle connectors, attachment plugs, and all other fittings, devices, power outlets, or apparatuses installed specifically for the purpose of delivering energy from the premises wiring to the electric vehicle.
- 1.5 EVSE Package – EVSE hardware, software, and network services furnished by the EVSP.
- 1.6 EVSE Operations and Maintenance (O&M) – Services required to operate and maintain the EVSE including but not limited to network connectivity and related services, remote monitoring and management services, replacement of parts and associated services necessary to keep the EVSE operational. EVSE O&M does not include maintenance and repair of the EV Service Connection and the EV Supply Infrastructure.
- 1.7 EVSE Owner – The entity that is responsible for paying the up front and ongoing costs associated with keeping the EVSE Package operational. The EVSE Owner is also the customer of record for PG&E for purposes of the EVSE and will be responsible for paying all electric bills associated with the EVSE’s operation under the selected PG&E Rate Plan. In general, the EVSE will be owned



and maintained by the Site Host. In situations in which a Site Host does not own the EVSE(s), the EVSE Owner assumes the responsibilities of the Site Host under this Contract pertaining to operations, maintenance and data collection.

- 1.8 EVSP – Electric vehicle service provider is an entity that provides EVSE hardware and software to enable electric vehicle charging. Regardless of whether an EVSP is a party to this contract they are expected to have separate contractual relationships with the Site Host and/or EVSE Owner that are complementary to those stated within this Contract.
  - 1.9 PG&E – Pacific Gas and Electric Company.
  - 1.10 Site(s) – the sites identified for the deployment of EVSE in Part A (Project Description).
  - 1.11 Rate Plan – A retail energy rate plan offered by PG&E. EVSE Owner will be the PG&E customer of record and will be responsible for paying the PG&E bill associated with the EVSE. The EVSE Owner may enroll in any applicable PG&E rate plan based on their service use. Detail on PG&E rates and eligibility criteria can be found at [https://www.pge.com/en\\_US/small-medium-business/energy-alternatives/clean-vehicles/ev-charge-network/electric-vehicle-rate-plans.page#:~:text=Business%20Low%20Use%20EV%20Rate,workplaces%20and%20multi%2Dunit%20dwellings](https://www.pge.com/en_US/small-medium-business/energy-alternatives/clean-vehicles/ev-charge-network/electric-vehicle-rate-plans.page#:~:text=Business%20Low%20Use%20EV%20Rate,workplaces%20and%20multi%2Dunit%20dwellings).
  - 1.12 Site Host –The Site Host owns or leases the Premises where the EVSE Packages are installed.
2. **Acknowledgement and Term:** All parties hereto agree to abide by the terms and conditions of this Contract for participation in the Program, including all requirements expressly incorporated by reference. The duration of this Contract (the “Term”) will commence on the date in which EVSE becomes operational and will continue in effect for the Term stated in Part A (Project Description) (unless otherwise earlier terminated pursuant to the terms herein). The EVSE will be deemed to be operational when both the EVSE commissioning is complete and the final inspection by the Authority Having Jurisdiction has been passed (as shown by the date of the final inspection certificate).
  3. **Rebate Conditions.**
    - 3.1 If a Site Host elects to own the EVSE and is eligible for a rebate, it will receive a one-time rebate equal to the cost of the charger, warranty, and ongoing network fees and maintenance costs for a term of eight years. The Site Host is responsible for supplying PG&E with all required rebate documentation.
    - 3.2 In order to receive the Rebate for a charger, EVSE Owner must furnish a completion package to PG&E within thirty (30) days after the EVSE becomes operational. PG&E’s Program Manager will provide details of the required documentation. The required documentation is subject to change in PG&E’s discretion. In general terms, the completion package will include: (1) proof of purchase or relevant documentation showing purchase of the designated number of qualified EVSE and the associated cost (with itemized cost/product breakdowns as designated by PG&E); (2) a copy of the network service agreement between Site Host and the EVSE network services provider; (3) a copy of the EVSE commissioning report; and (4) Site Host’s W9 form with tax ID information. The Rebate will be paid in a single lump sum after PG&E receives the required documentation. Except for payment of the Rebate, PG&E has no obligations with respect to EVSE Operations and Maintenance.
    - 3.3 To comply with regulatory reporting requirements, every six months during the Term EVSE Owner must furnish to PG&E copies of the invoices and receipts for ongoing maintenance, service fees and networking costs incurred by EVSE Owner for the EVSE. EVSE Owner acknowledges that these invoices and receipts are subject to inspection by the CPUC.
  4. **Selection of Electric Vehicle Service Equipment Package:** EVSE Owner may choose any EVSP from the list of qualified EVSPs, and any EVSE Package offered by that EVSP. It is the responsibility of

the EVSE Owner to ensure that the selected EVSE Package is included in PG&E's current list of Program qualified products. EVSE Owner acknowledges that PG&E makes no representations regarding manufacturers, dealers, contractors, materials or workmanship of the EVSE Package. Site Host and EVSE Owner agree that PG&E has no liability whatsoever concerning the quality and safety of the EVSE Package. EVSE Owner shall install, operate and maintain the number and type of EVSE Packages described in Part A (Project Description). In all cases, PG&E's responsibility is limited to the EV Service Connection and the EV Supply Infrastructure. The cost of establishing the EV Service Connection and EV Supply Infrastructure will be borne by PG&E, except as stated in Part A (Project Description).

5. **Additional Services from EVSP:** The EVSP may offer and contract directly with the Site Host and/or EVSE Owner to provide additional or complementary services that are not described in Part A (Project Description), as long as these services do not materially interfere with the objectives of the Program. The costs of additional EVSP services (including any additional work required for the EV Service Connection or EV Service Infrastructure), and any cost related to O&M of any additional EVSP services, will not be borne by PG&E pursuant to this Contract.
6. **Installation Process:**
  - 6.1 PG&E and/or its contractors shall, at PG&E's sole cost and expense (except as stated in Part A (Project Description), if applicable), design and construct the EV Service Connection and EV Supply Infrastructure in compliance with the terms of this Contract, as well as all applicable local, state and federal laws and regulatory requirements.
  - 6.2 Site Host is responsible for (i) providing or obtaining required easements (refer to section 10 below), and (ii) providing all disclosures regarding known conditions, including but not limited to hazardous or contaminated materials, located at the Site.
  - 6.3 Arrangements for removal of any hazardous or contaminated materials, and any other environmental remediation, will be Site Host's responsibility. If PG&E is to assume any responsibility for remediation of any of these conditions this must be expressly stated in Part A (Project Description) and will be limited to the responsibilities described therein.
  - 6.4 EVSE Owner will be PG&E's single point of contact for the EVSE installation project and is responsible for coordinating all communications among EVSE Owner, Site Host and relevant third parties with respect to the installation process, for securing required approvals with respect to preliminary and final designs.
  - 6.5 A preliminary layout of proposed facilities will be provided by PG&E to EVSE Owner for Site Host and EVSE Owner review and approval; such approval will not unreasonably be withheld. After Site Host and EVSE Owner approval of the preliminary design, PG&E will coordinate with the EVSE Owner if there are any proposed material changes. A final design with no material changes from the agreed upon design, will be provided by PG&E to EVSE Owner prior to any installation activities. PG&E, Site Host, and EVSE Owner will approve final design prior to construction beginning. Once design is approved no material changes will be made without approval from PG&E, Site Host, and EVSE Owner.
  - 6.6 PG&E will provide an estimated installation schedule for the EV Supply Infrastructure after execution of any required easements and the approved building permit. Should the schedule require modification, PG&E shall notify EVSE Owner within a reasonable time of such changes. PG&E does not guaranty that the EVSE Supply Infrastructure will be completed within the time frame shown in the installation schedule.
  - 6.7 The EVSE Owner and/or its contractors shall install the EVSE, in compliance with the terms of this Contract, as well as all applicable local, state and federal laws and regulatory requirements. The EVSE Owner is responsible for all costs of the EVSE Package and its installation. PG&E will



assess whether the installation complies with quality and safety standards before confirming project completion and delivering any applicable Rebates.

- 6.8 Upon completion of installation of the EVSE, the EVSE Owner understands and acknowledges that EVSE Owner will be responsible for EVSE Operations and Maintenance.
7. **EV Drivers Right to Access:** Access to or use of the EVSE shall not be restricted for reasons including, but not limited to, race, color, religion, age, sex, national origin, ancestry, physical or mental disability, or any basis prohibited by applicable law.
  8. **Duty to Notify:** Site Host warrants that it is the occupier of the Premises as an owner or tenant and has legal control of the Premises. Site Host has a duty to promptly notify PG&E when Site Host becomes aware of any unsafe, inoperable or damaged EV Service Connection or EV Supply Infrastructure equipment. In addition, Site Host and EVSE Owner shall promptly report all claims and/or incidents associated with the EV Service Connection or the EV Supply Infrastructure to PG&E or its designated representative(s), and shall promptly thereafter confirm in writing any injury, loss, or damage incurred by Site Host and/or EVSE Owner or any third party.
  9. **Accessibility Requirements:** The installation of the EVSE and EV Service Connection is required to comply with the Americans with Disabilities Act (ADA) and California Building Standards. PG&E is responsible for the costs of complying with these standards as they relate to the installation of EVSE Service Connection and EV Supply Infrastructure. Site Host understands and accepts that such standards may impact parking layouts and reduce the number of non-accessible parking spaces available. Site Host understands and accepts that changes to initial design representations may occur during the design, construction and operational phases of the EVSE as may be dictated by design constraints, by law or regulation or by local jurisdictional authorities.
  10. **Easement Requirement:** An easement may be required to install and maintain the EV Service Connection and EV Supply Infrastructure. PG&E will use existing easements when practicable to minimize encumbrances on the Site(s). If a new easement is required, access rights will follow standard utility requirements for providing electrical service. PG&E will determine if a new easement is required. PG&E will provide the easement documentation to Site Host for execution by the landowner and/or other relevant third parties such as secured lenders. If the duly executed easement with applicable consents is not provided to PG&E's satisfaction (based on standard utility requirements) within 60 days after PG&E provides the documentation to Site Host, PG&E may remove the affected Premises from the Program. If the EV Service Connection must cross property owned by a third party to serve Site Host, PG&E may, at its option, install such EV Service Connection after appropriate rights of way or easements, satisfactory to PG&E, are obtained. PG&E will pay for the cost of third party easements and the estimated cost will be included in the make-ready cost of EVSE Service Connection and EV Supply Infrastructure for that site. Upon termination of the Contract, PG&E shall, within thirty (30) days written demand therefor, execute and deliver to Site Host (or the relevant third party) a quitclaim of any easement granted pursuant to this Contract.
  11. **Access to Site Host's Premises:** PG&E shall at all times have the right to enter and leave the Site Host's Premises for any purpose connected with the furnishing of electric service to the EV Supply Infrastructure and EV Service Connection (meter reading, inspection, testing, routine repairs, replacement, maintenance, vegetation management, emergency work, etc.) and the exercise of any and all rights secured to it by law, or under PG&E's applicable tariff schedules. Except in emergencies, PG&E shall use best efforts to provide Site Host/EVSE Owner with advance notice of work that is likely to affect access to or use of the Site, consistent with PG&E's standard utility practices. If Site Host does not grant PG&E reasonable access to the Premises, then PG&E may, consistent with PG&E's standard utility practices, deenergize the EV Supply Infrastructure or EV Service Connection until access is granted.
  12. **EVSE Operation and Maintenance:** The EVSE Owner is required to operate and maintain the EVSE for the Term of this Contract. EVSE Owner will pay all O&M costs associated with the EVSE. Site Host shall maintain the common area improvements immediately surrounding the EVSE in good and safe condition.

Such maintenance by Site Host of the immediately surrounding common areas shall include, but not be limited to, pavement maintenance and snow removal services.

13. **Billing:** EVSE Owner will be the PG&E customer of record for the EVSE and will be served an applicable rate. As the customer of record, EVSE Owner will be responsible for paying the PG&E bill associated with the EVSE.
14. **Changing Rate Plan:** EVSE owner may change Rate Plan during the Term, but must remain on a retail PG&E rate for the duration of the Term. If EVSE owner switches to a non-retail PG&E rate (e.g., a wholesale tariff) during the Term, Site Host shall bear the full cost and sole expense, as circumstances may dictate, for losses incurred by PG&E on behalf of ratepayers, such as pro-rated costs of equipment, site design and installation.
15. **Low Carbon Fuel Standard (LCFS) Credits:** PG&E agrees the EVSE owner will be entitled to all LCFS credits and associated financial benefits arising from use of the EVSE.
16. **Reliability:** PG&E does not guarantee uninterrupted service. At its own expense, EVSE Owner may pursue options to ensure that any impact to operations from potential loss of power is sufficiently mitigated.
17. **Changes to EVSE.**
  - 17.1 **Replacement:** Site Host may replace EVSE during the Term. Site Host must notify PG&E ahead of replacement to ensure the EV Service Infrastructure can accommodate the additional load and new EVSE complies with necessary CPUC requirements for the Program. If adequate infrastructure does not exist, Site Host must request increased capacity in accordance with the provisions of CPUC filed tariffs such as Electric Rule 16. Any replacements will be at Site Host's expense and its liability.
  - 17.2 **Relocations:** Should Site Host or EVSE Owner request relocation of EVSE or parts thereof at any point in time, such relocation shall be per mutually agreeable terms and shall be at sole expense of the party making the request and in accordance with any Program requirements, laws, regulations or other applicable jurisdictional requirements. Additionally, if requested by PG&E, Site Host shall either amend the Easement to include the legal description of the new location or enter into a new Easement with PG&E.
  - 17.3 **Expansion:** Site Host must coordinate with PG&E prior to expansion of chargers or charger capacity. Any additional installations or related work will be at Site Host's expense and liability.
18. **Permission to Use Data:** EVSE Owner and Site Host agree to allow PG&E, its agents and representatives to access and use data relating to the use of the EVSE (including usage data from the EVSE and EVSE performance data supplied directly to PG&E from the EVSP) ("Usage Data") for PG&E's internal use, for the enhancement of the Program and similar programs and for regulatory reporting purposes, and all such use shall be in accordance with applicable laws and regulations. If Site Host or the EVSE Owner does not control access to Usage Data, EVSE Owner will direct the person who controls such access to make Usage Data available to PG&E in a file format reasonably acceptable to PG&E and consistent with regulatory reporting requirements. All data shall be anonymized to remove any personal information before it is provided to PG&E.
19. **Representations:** Site Host and EVSE Owner understand that participation in the Program shall not be construed as creating any agency, partnership, or other form of joint enterprise between the Site Host, EVSE Owner, PG&E, or their affiliates, contractors, vendors, representatives or designees nor create any obligations or responsibilities on their behalf except as may be expressly granted in writing, nor make any representations of any kind to this effect. Site Host represents and warrants that it is either (i) the fee title owner of the Premises and has the right to grant the easement and other rights of access referred to in this Contract, or (ii) it is the lessee of the Premises and, subject to obtaining an easement from the landlord as described in this Contract, has the power, authority and capacity to bind itself to this

Contract and to perform each and every obligation required of Site Host and the EVSE Owner (if applicable).

20. **Regulatory Changes:** PG&E may initiate changes to the Program as necessary to comply with CPUC directives. PG&E shall endeavor to provide Site Host and EVSE Owner with advance notice of any such changes.
21. **Compliance with Laws:** All parties shall comply with all applicable federal, state, and local statutes, rules, regulations, laws, orders and decisions that relate to or govern its participation in the Program and/or a party's interactions with customers in connection with the Program, including operation of the EVSE.
22. **PG&E Termination or Suspension:** PG&E may terminate, or for any duration suspend, Site Host's or EVSE Owner's participation in the Program, or operation of EVSE to comply with regulatory mandates or for cause including but not limited to: failure to provide or maintain terms of easement, breach of this Contract, failure to abide by Program terms and conditions, permitting issues, exceptional installation costs, environmental concerns, or any other material reason(s) not in the best interests of the Program or PG&E's ratepayers.
23. **Assignment.** If the Site Host or EVSE Owner wishes to assign its rights and obligations of the EVSE Package to a new Site Host or EVSE Owner prior to the end of the Term, the new Site Host or EVSE Owner may assume all rights and obligations for the remaining term with PG&E consent.
24. **Early Removal, Termination or Cessation of EVSE Service:** Should Site Host or EVSE Owner request removal of EV Supply Infrastructure or termination of an EV Service Connection before the end of the Term (an "Early Termination"), the Site Host or EVSE Owner who requests removal shall be responsible (and shall reimburse PG&E, as applicable) for the full cost and expense of such removal. In addition, if there is an Early Termination or if the EVSE Owner ceases to make EVSE available for use as required by this Contract before the end of the Term, then the EVSE Owner will pay PG&E the actual costs, as circumstances may dictate, for losses incurred by PG&E on behalf of ratepayers, such as pro-rated costs of equipment, site design and installation. Site Host or EVSE Owner may, at any time within the Term request from PG&E projected and final costs associated with such a removal request. Upon such Early Termination or cessation of service, the EVSE Owner may elect option 2 (but not option 1) in the "End of Term" paragraph below.
25. **End of Term:** At the end of the Term, the Site Host / EVSE Owner will have the following options;
  - 25.1 **Continue to operate the EVSE,** in which case PG&E will, at its option, either:
    - 25.1.1 Transfer ownership of the EV Supply Infrastructure to the Site Host and provide a quitclaim for the associated easement for a nominal fee, in which case PG&E will have no further obligations with respect to the EV Supply Infrastructure, and electrical service for the EV Service Connection will be provided in accordance with PG&E's standard utility practices and applicable tariffs; or
    - 25.1.2 Continue to operate and support the EV Supply Infrastructure in which case PG&E may charge an annual maintenance fee and the easement will remain in place.
    - 25.1.3 In either case, Site Host/EVSE Owner shall have no further obligations to PG&E under this Contract except for the indemnity set forth below.
  - 25.2 **Abandon the EV Supply Infrastructure in place.** PG&E delivers quitclaim for easement and easement is removed by Site Host. PG&E has no further obligations with respect to the abandoned Service Connection and EV Supply Infrastructure.
26. **Indemnity:** Site Host and EVSE Owner (each an "Indemnitor") shall indemnify, hold harmless and defend PG&E, its affiliates, subsidiaries, parent company, officers, managers, directors, agents, and

employees, from and against all claims, demands, losses, damages, costs, expenses, and liability (legal, contractual, or otherwise), which arise from or are in any way connected with any: (i) injury to or death of persons, including but not limited to employees of PG&E or Indemnitor; (ii) injury to property or other interests of PG&E, Indemnitor, or any third party; (iii) violation of a local, state, or federal common law, statute or regulation, including but not limited to environmental laws or regulations; (iv) strict liability imposed by any law or regulation; so long as such injury, violation, or strict liability (as set forth in (i) - (iv) above) arises from or is in any way connected with Indemnitor's performance of, or failure to perform, this Contract. This indemnification obligation shall not apply to the extent that such injury, loss or damage is caused by the negligence or willful misconduct of PG&E, its officers, managers, or employees. Indemnitor shall, on PG&E's request, defend any action, claim, or suit asserting a claim which might be covered by this indemnity, using counsel acceptable to PG&E. Indemnitor shall pay all costs and expenses that may be incurred by PG&E in enforcing this indemnity, including reasonable attorney's fees. To the extent necessary, each Party was represented by counsel in the negotiation and execution of this Contract.

27. **Insurance Requirements:** Site Host shall procure, carry and maintain the following insurance coverage:

27.1 **General Liability Insurance.** The limit shall not be less than Two Million Dollars (\$2,000,000) each occurrence for bodily injury, property damage and personal injury. Coverage shall: a) By "Additional Insured" endorsement add as insureds PG&E, its directors, officers, agents and employees with respect to liability arising out of work performed by or for the 'Site Host'; b) Be endorsed to specify that the 'Site Host' insurance is primary and that any insurance or self-insurance maintained by PG&E shall not contribute with it.

27.2 **Property Insurance** - Covering against all risks of physical loss or damage to EVSE with limits equivalent to the replacement cost of the EVSE.

27.3 Additional Insurance Provisions.

27.3.1 In the event that Site Host does not own the EVSE, Site Host shall ensure that EVSE Owner carries comparable insurance to that required of Site Host under this Agreement.

27.3.2 Before commencing performance of work under this Agreement, Site Host and/or EVSE Owner shall furnish PG&E with certificates of insurance and endorsements of all required insurance. PG&E may inspect the original policies at any time.

27.3.3 Upon request, Site Host and/or EVSE Owner shall furnish PG&E evidence of insurance for agents or contractors hired to perform installation or O&M of the EVSE.

28. **Casualty:** If all or any portion of the EVSE on the Site are damaged or destroyed by fire or other casualty which reasonably materially and adversely affects the operation of the EVSE (any, a "**Casualty**"), and if Site Host elects not to repair or replace the affected EVSE, then Site Host and EVSE Owner shall have the right to terminate the Contract by written notice to PG&E in which event the Contract shall terminate on the date that is 10 days after the date of the relevant party's termination notice.

29. **Dispute Resolution:** This Contract, and any and all disputes arising out of or relating to this Contract, shall be governed by and construed under the laws of the State of California, without reference to its conflicts of law provisions. If a dispute arises with respect to this Contract or performance hereunder, a party may request mediation by written notice to the other Party. The mediation shall be conducted by a mutually-agreeable mediator with appropriate experience. All negotiations and any mediation conducted pursuant to this provision are confidential and shall be treated as compromise and settlement negotiations, to which Section 1119 of the California Evidence Code shall apply, and Section 1119 is incorporated herein by reference. In the event that mediation fails to resolve such dispute, the parties retain all rights and defenses with respect to such dispute. Any proceeding related to this Contract or a party's performance or non-performance hereunder will be instituted and maintained exclusively in the

federal or state courts sitting in the City and County of San Francisco, and each party irrevocably submits to the exclusive jurisdiction of those courts.

30. **No Partnership:** This Contract shall not be construed as creating a partnership, joint venture, agency relationship, franchise or association, nor shall this Contract render PG&E and Site Host or EVSE Owner liable as partners, co-venturers or principals.
31. **Enforceability:** If any of the provisions, or application of any of the provisions, of this Contract are held to be illegal or invalid by a court of competent jurisdiction or arbitrator/mediator, all impacted Parties shall negotiate an equitable adjustment in the provisions of this Contract with a view toward effectuating the purpose of this Contract. The illegality or invalidity of any of the provisions, or application of any of the provisions, of this Contract will not affect the legality or enforceability of the remaining provisions or application of any of the provisions of the Contract.
32. **Integration:** This Contract, including all items incorporated herein by reference, constitutes the entire agreement and understanding between the Parties as to the subject matter of the Contract. It supersedes all prior or contemporaneous agreements, commitments, representations, writings, and discussions between parties, whether oral or written, express or implied, that relate in any way to the subject matter of this Contract. This Contract has been induced by no representations, statements or agreements other than those expressed herein. Neither party shall be bound by any prior or contemporaneous obligations, conditions, warranties or representations with respect to the subject matter of this Contract.
33. **Survival:** The provisions of this Contract which by their nature should survive expiration, cancellation or other termination of this Contract, including but not limited to provisions regarding warranty, indemnity, insurance, confidentiality, document retention, business ethics and availability of information, shall survive such expiration, cancellation or other termination.
34. **Notices:** Any and all notices shall be in writing and addressed to the parties at the addresses specified below or such other addresses as either party may direct by notice given in accordance with this section, and shall be delivered in one of the following manners: (i) by personal delivery, in which case notice shall be deemed to have been duly given when delivered; (ii) by certified mail, return receipt requested, with postage prepaid, in which case notice shall be deemed to have been duly given on the date indicated on the return receipt; or (iii) by reputable delivery service (including by way of example and not limitation Federal Express, UPS and DHL) which makes a record of the date and time of delivery, in which case notice shall be deemed to have been duly given on the date indicated on the delivery service's record of delivery.

34.1 Notices to PG&E shall be sent to:

Pacific Gas and Electric Company  
Attn: EV Charge Schools and Parks Program Manager  
77 Beale St  
San Francisco, CA 94105  
Email Address: EVSchoolsandParks@pge.com

34.2 Notices to Site Host and/or the EVSE Owner shall be sent to the applicable address and addressee shown in Part A (Project Description).

The Parties have executed this Contract on the dates indicated below, to be effective upon the later date.



Oakland Unified School District -

East Oakland PRIDE

Company Name (Site Host)

  
Signature

TADASHI NAKADEGAWA

Print Name

DEP CHIEF FAC

Title

5/24/2022

Date



Mike Hutchinson, President,  
Board of Education  
4/13/2023

Oakland Unified School District -

East Oakland PRIDE

Company Name (EVSE Owner)

  
Signature

TADASHI NAKADEGAWA

Print Name

DEP CHIEF FAC

Title

3/24/2022

Date



Kyla Johnson Trammell  
Secretary, Board of Education  
4/13/2023

**PACIFIC GAS AND ELECTRIC COMPANY**

  
Signature

Meredith Morford

Print Name

Manager, Project Delivery

Title

3/25/22

Date

PRELIMINARY DESIGN  
SCALE: 1" = 20'

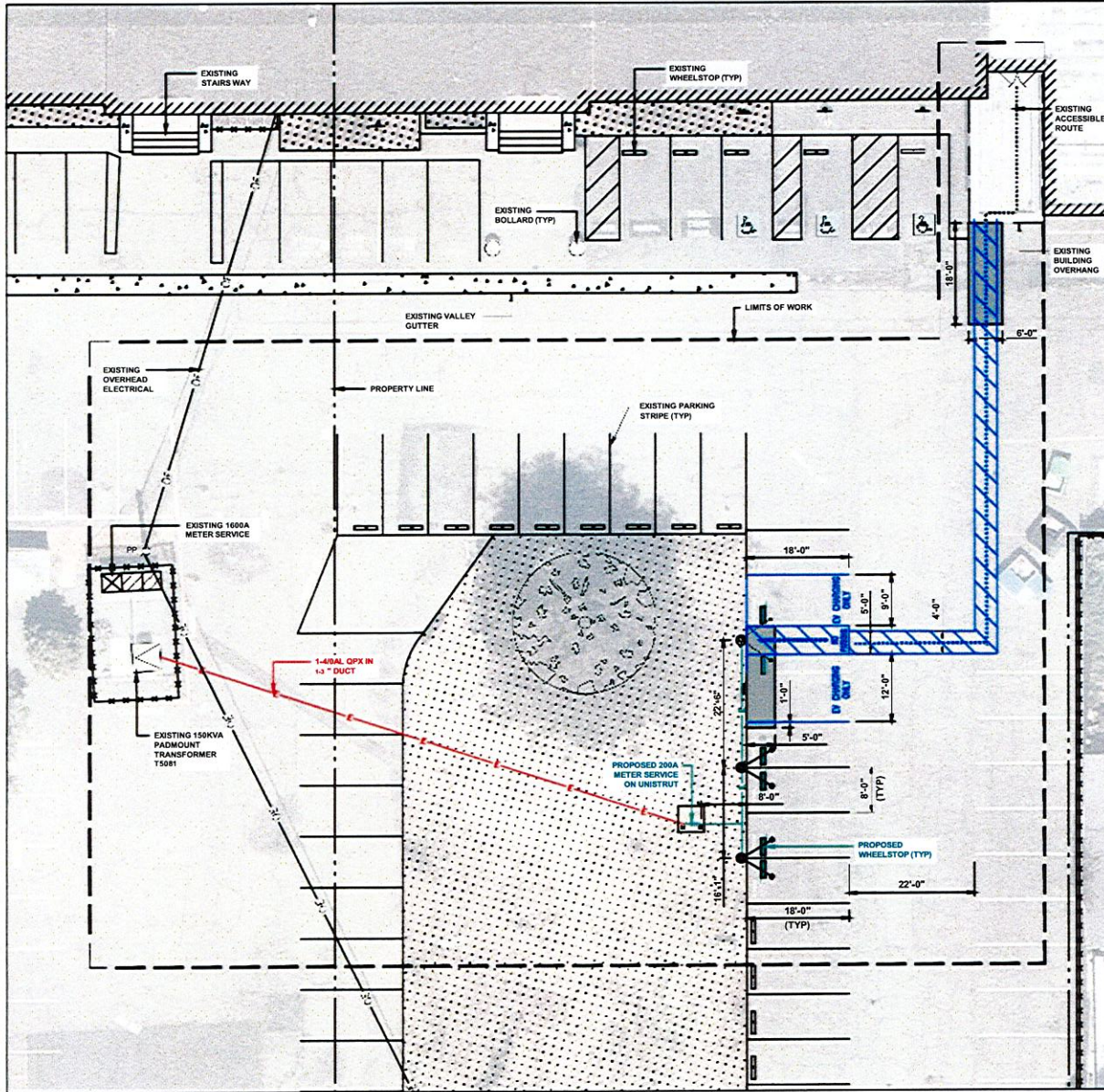

**PROPOSED SYMBOL LEGEND:**

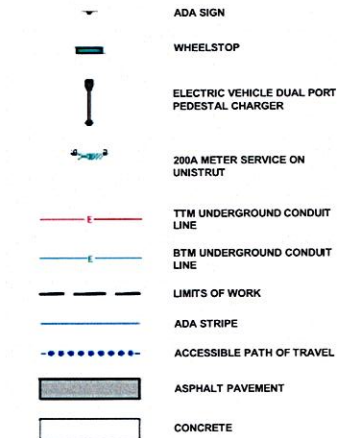

**SCOPE OF WORK:**  
PROJECT SCOPE INCLUDES (3) LEVEL 2 CHARGERS, THE STALLS ARE LOCATED IN THE NORTHWEST SIDE OF PARKING LOT, THE EV STALLS WILL BE SERVICED BY PEDESTAL MOUNT EVSE. SEE DETAILED SITE LAYOUT FOR MORE INFORMATION.

THIS SITE IS LOCATED IN FLOOD HAZARD ZONE X.

**SITE WALK NOTES:**

- TTM NOTES:**  
1. THE EXISTING TRANSFORMER HAS CAPACITY FOR THE ADDITIONAL LOAD.
- BTM NOTES:**  
1. THE SCHOOL CURRENTLY HAS A TRAFFIC CIRCULATION ISSUE AND LIMITED ADA TIE IN POINTS. THIS LIMITS WHICH STALLS CAN BE USED FOR CHARGER PLACEMENT.  
2. ONLY ONE DOOR HAS RAMP ACCESS WHICH IS THE ONLY OPTION FOR ADA TIE IN.  
3. THE EXISTING TRASH DUMPSTERS WILL NEED TO BE SHIFTED AROUND IN ORDER TO PROVIDE SPACE FOR THE PROPOSED ADA PATH OF TRAVEL STRIPING.  
4. EXISTING ADA PATH OF TRAVEL IS ASSUMED AND SHOULD BE CONFIRMED WITH DSA APPROVED PLANS.  
5. CHARGER CORD LENGTH IS 18 FEET.

BILL OF MATERIALS		
ITEM	UNIT	QUANTITY
BTM 200A, 208/120V, 3Ø, METER SERVICE ON UNISTRUT	EACH	1
BTM 1" PVC CONDUIT	LF	100
BTM 1" RMC CONDUIT	LF	15
TTM 3" PVC CONDUIT	LF	105
TTM 3" RMC CONDUIT	LF	5
BTM (4) #8 AWG THWN-2 CU + (1) #8 AWG THWN-2 CU EGC	LF	155
TTM 4/0AL OPX	LF	120
TTM 36" WIDE OPEN CUT TRENCH - HARDSCAPE	LF	55
TTM 36" WIDE OPEN CUT TRENCH - SOFTSCAPE	LF	55
BTM 24" WIDE OPEN CUT TRENCH - SOFTSCAPE	LF	50
TTM RESTORE ASPHALT PAVEMENT	SF	150
BTM RESTORE ASPHALT PAVEMENT	SF	200
TTM RESTORE SOFTSCAPE	SF	165
BTM RESTORE SOFTSCAPE	SF	100
BTM CONCRETE WHEEL STOP	EACH	6
BTM EQUIPMENT CONCRETE	SF	25
BTM ADA STRIPING	EACH	2
BTM ADA SIGNAGE	EACH	1
BTM EV CHARGER FOUNDATION	EACH	3

NOTE: ALL QUANTITIES ARE ESTIMATED AND SHOULD BE VERIFIED BY THE CONTRACTOR

STALL AND STATION COUNT	
IMPACTED EXISTING	QUANTITY
STANDARD STALLS	7
TOTAL	7
PROPOSED EV CHARGING	QUANTITY
VAN ACCESSIBLE STALLS	1
STANDARD ACCESSIBLE STALLS	1
STANDARD STALLS	4
TOTAL	6
EV CHARGING STATIONS	QUANTITY
LEVEL 2 (7.2 KW NOMINAL / 6.2 KW ACTUAL) DUAL PORT - PEDESTAL MOUNT	3
TOTAL	3
ANTICIPATED LOAD	TOTAL KW
CHARGEPOINT CT 4000 @ 6.2 KW	18.6



CONSULTANT  
Blair Church & Flynn  
1000 Lakeside Drive  
Oakland, CA 94612  
Tel: 415.764.1100  
Fax: 415.764.1101  
www.blairchurchandflynn.com

DRAWN BY:	MAI DER VANG
CHECKED BY:	CASSIE BURGER
DATE:	10-28-2021
SCALE AS NOTED	

SHEET NO. 2 OF 2 SHEETS

PRELIMINARY DESIGN  
SCALE: 1" = 50'

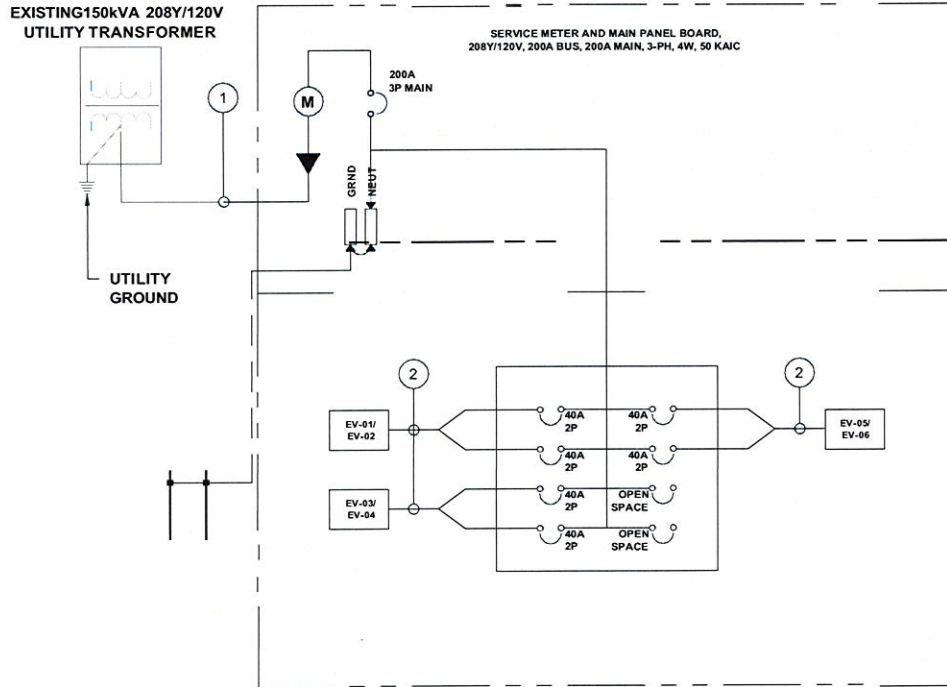

**NOTES:**

1. CONTRACTOR TO FIELD VERIFY MAIN FEED BREAKER SUPPORTING DISTRIBUTION PANEL IS APPROPRIATELY SIZED TO SUPPORT THE LOAD. CONTRACTOR SHALL CONTACT THE ENGINEERING TEAM IMMEDIATELY IF BREAKER IS FOUND TO BE INSUFFICIENT.
2. CONDUCTOR LENGTHS ARE ESTIMATES ONLY. LENGTHS ARE BASED ON DIAGRAMMATICAL MEASUREMENTS AND APPROXIMATED BURIED DEPTHS. THE EXACT ROUTING PATH, CONDUCTOR RUN LENGTHS AND INSTALLATION SHALL BE DETERMINED BY THE CONTRACTOR IN THE FIELD BASED ON EXISTING SITE CONDITIONS AND PHYSICAL MEASUREMENTS. CONTRACTOR TO ORDER CONDUCTOR BASED ON FIELD MEASUREMENTS.
3. CHARGING UNITS ARE EQUIPPED WITH AN INTEGRATED CONTACTOR TO PREVENT BACK FEEDING OF POWER TO THE SOURCE.
4. LOAD LIMITING FUNCTION OF CHARGERS SHALL BE CONFIGURED AS NEEDED SUCH THAT THE TOTAL LOAD OF ALL CHARGERS DOES NOT EXCEED PANEL RATINGS OR UTILITY TRANSFORMER CAPACITY.
5. ALL PVC TO BE SCHEDULE 40 UNLESS OTHERWISE INDICATED.

**CIRCUIT NOTES**

NO	FROM	TO	CONFIGURATION
①	UTILITY TRANSFORMER	SERVICE METER AND MAIN PANEL BOARD	SEE PG&E UTILITY DRAWINGS
②	SERVICE METER AND MAIN PANEL BOARD	LEVEL 2 EV CHARGER (DUAL PORT)	1" BELOW GRADE PVC WITH (4) #8 AWG CU THWN-2 AND (1) #8 AWG CU THWN-2 GROUND CONDUCTOR

AC RUN MAXIMUM LENGTHS IS 135' INCLUDING BURIED DEPTH. ANY AC RUN LENGTHS BEYOND THIS MAXIMUM SHALL BE ADDRESSED WITH THE APPROPRIATE ENGINEERING TEAMS AS SOON AS THE SITUATION ARISES.

MAXIMUM AC VOLTAGE DROP (%)	1.3%
AVERAGE AC VOLTAGE DROP (%)	0.9%



CONSULTANT	DRAWN BY: DEREK CARTER	SHEET NO. 2
Blair, Church & Flynn	CHECKED BY: DARIO ROMERO	OF 2 SHE
DATE: 10-28-2021	SCALE AS NOTED	





## DIVISION OF FACILITIES PLANNING AND MANAGEMENT ROUTING FORM

### Project Information

<b>Project Name</b>	East Oakland Pride Elementary School EV Charger Installation	<b>Site</b>	107
<b>Basic Directions</b>			
Services cannot be provided until the contract is awarded by the Board or is entered by the Superintendent pursuant to authority delegated by the Board.			
Attachment Checklist	<input checked="" type="checkbox"/> Proof of general liability insurance, including certificates and endorsements, if contract is over \$15,000 <input checked="" type="checkbox"/> Workers compensation insurance certification, unless vendor is a sole provider		

### Contractor Information

Contractor Name	PG & E Company	Agency's Contact	Meredith Morford		
OUSD Vendor ID #		Title	President		
Street Address	77 Beale Street	City	SF	State	CA Zip 95008
Telephone		Policy Expires			
Contractor History	Previously been an OUSD contractor? <input type="checkbox"/> Yes <input checked="" type="checkbox"/> No		Worked as an OUSD employee? <input type="checkbox"/> Yes <input checked="" type="checkbox"/> No		
OUSD Project #	23103				

### Term of Original/Amended Contract

Date Work Will Begin (i.e., effective date of contract)	3-24-2022	Date Work Will End By (not more than 5 years from start date; for construction contracts, enter planned completion date)	12-31-2031
		New Date of Contract End (If Any)	

### Compensation/Revised Compensation

If New Contract, Total Contract Price (Lump Sum)	\$ 98,304.00	If New Contract, Total Contract Price (Not To Exceed)	\$
Pay Rate Per Hour (if Hourly)	\$	If Amendment, Change in Price	\$
Other Expenses		Requisition Number	

### Budget Information

*If you are planning to multi-fund a contract using LEP funds, please contact the State and Federal Office before completing requisition.*

Resource #	Funding Source	Org Key	Object Code	Amount
9655/9924	Fund 21 Measure Y	210-9655-0-9924-8500-6274-107-9180-9005-9999-23103	6274	\$ 98,304.00

### Approval and Routing (in order of approval steps)

Services cannot be provided before the contract is fully approved and a Purchase Order is issued. Signing this document affirms that to your knowledge services were not provided before a PO was issued.

	<b>Division Head</b>	<b>Phone</b>	510-535-7038	<b>Fax</b>	510-535-7082
1.	<b>Executive Director, Facilities Planning and Management</b>				
	Signature <i>[Signature]</i>	Date Approved	3/6/23		
2.	<b>General Counsel, Department of Facilities Planning and Management</b>				
	Signature <i>[Signature]</i> Lozano Smith, approved as to form (limited)	Date Approved	3/3/23		
3.	<b>Deputy Chief, Facilities Planning and Management</b>				
	Signature <i>[Signature]</i> For T.N.	Date Approved	3/6/23		
4.	<b>Chief Financial Officer</b>				
	Signature	Date Approved			
5.	<b>President, Board of Education</b>				
	Signature	Date Approved			