



Board Office Use: Legislative File Info.	
File ID Number	26-0961
Introduction Date	5/13/2026
Enactment Number	
Enactment Date	

Board Cover Memorandum

To Board of Education

From Denise G. Saddler, EdD, Interim Superintendent
Preston Thomas, Chief Systems and Services Officer
Devinder Kumar, Senior Executive Director, Nutrition Services Department

Meeting Date May 13, 2026

Subject Amendment No. 1 Services Agreement - Culinary Depot - Service Line Equipment Services - Nutrition Services Department

Ask of the Board Approval by the Board of Education of Amendment No. 1, Service Line Equipment Services by and between the District and Culinary Depot, Spring Valley, NY to exercise the first of two one-year options to renew the Service Line Equipment Services Contract, for an amount not to exceed \$400,000.00, for the period of July 1, 2026 through June 30, 2027. All other terms and conditions of the agreement remain in full force and effect.

Background and Discussion Amendment No. 1, Service Line Equipment Services RFP#26-162NS

Fiscal Impact There is no change in the not to exceed amount of \$400,000.00. Funding Source is 5310/Child Nutrition School Program and 7032/2022 Kitchen Infra & Training.

Attachment(s)

- Culinary Depot, Amendment No. 1
- Vendor Renewal Commitment Letter
- 25-2728 Award of RFP 26-162NS - Service Line Equipment K-12 Meal Program Agreement - Culinary Depot - Nutrition Services Department, approved December 10, 2025



AMENDMENT NO. 1 to
Service Line Equipment Services K-12 Meal Program Contract RFP No. 26-162NS
(“Original Agreement”)

This Amendment (“AMENDMENT”) amends the attached Original Agreement, inclusive of any prior amendments to the Original Agreement (together, “AGREEMENT”). Except as explicitly stated herein, all provisions and terms of the AGREEMENT remain unchanged and in full force and effect as originally stated.

1. The PARTIES hereby agree to amend the AGREEMENT as stated herein.

A. Services.

- The SERVICES are unchanged.
- The SERVICES have changed as indicated below:
 - A description of the changes in the SERVICES is attached.
 - The changes in the SERVICES involve the following:

B. Term.

- The term of the AGREEMENT is unchanged.
- The term of the AGREEMENT has changed as indicated below:

Original End Date: June 30, 2026

New End Date: June 30, 2027

C. Compensation.

- The not-to-exceed amount in the AGREEMENT is unchanged
- The not-to-exceed amount in the AGREEMENT has changed as indicated below:

Original not-to-exceed amount is \$400,000 per fiscal year.

The original not-to-exceed amount shall be <u>increased</u> by: \$ _____	OR	The original not-to-exceed amount shall be <u>decreased</u> by: \$ _____
--	----	--

The new not-to-exceed amount is \$_____.

- D. **Insurance.** To the extent that the AGREEMENT required less than following insurance coverage amounts, by signing this AMENDMENT, VENDOR agrees, unless waived under the terms of the AGREEMENT, that it shall maintain Commercial General Liability Insurance with limits of at least one million dollars (\$1,000,000) per occurrence, and two million dollars (\$2,000,000) aggregate. All other terms in the AGREEMENT regarding Commercial General Liability Insurance remain the same.
- E. **Suspension.** To the extent that the AGREEMENT did not contain a provision regarding suspension of the AGREEMENT, VENDOR agrees, by signing this AMENDMENT, that if OUSD, at its sole discretion, develops health and safety concerns related to the VENDOR's provision of SERVICES, then the OUSD Superintendent or an OUSD Chief may, upon approval by OUSD legal counsel, issue a notice to VENDOR to suspend this AGREEMENT, in which case VENDOR shall stop providing SERVICES under this AGREEMENT until further notice from OUSD. OUSD shall compensate VENDOR for the SERVICES satisfactorily provided through the date of suspension.
- F. **Legal Notices.** To the extent the AGREEMENT did not contain the following provisions, legal notices may be sent either (i) via email, (ii) personally delivered during normal business hours, or (iii) sent by U.S. Mail (certified, return receipt requested), to the contact identified in the AGREEMENT. VENDOR agrees that the address for legal notice to OUSD is 1011 Union St., Site 946, Oakland, CA 94607.
2. The PARTIES acknowledge that this AMENDMENT, its contents, and all incorporated documents are public documents and will be made available by OUSD to the public online via the Internet.
 3. Each PARTY has the full power and authority to enter into and perform this AMENDMENT, and the person(s) signing this AMENDMENT on behalf of each PARTY has been given the proper authority and empowered to enter into this AMENDMENT, except that only the Superintendent, Chiefs, Deputy Chiefs, and the General Counsel have authority under the Education Code or Board Policy to sign contracts for OUSD and only under limited circumstances, with ratification by the OUSD Governing Board being required. VENDOR agrees not to accept the signature of another other OUSD employee as having the proper authority and empowered to enter into this AMENDMENT or as legally binding in any way.
 4. OUSD shall not be bound by the terms of this AMENDMENT unless and until it has been (i) formally approved by OUSD's Governing Board or (ii) validly and properly executed by the OUSD Superintendent, Chiefs, Deputy Chiefs, or the General Counsel as authorized by the Education Code or Board Policy, and no payment shall be owed or made to VENDOR absent such formal approval or valid and proper execution.

IN WITNESS WHEREOF, the PARTIES hereto agree and execute this AMENDMENT and to be bound by its terms and conditions:

VENDOR

Name: Daniel Paredes

Signature: *Daniel Paredes*

Position: Government Sales Rep, Culinary Depot

Date: 3/19/2026

OUSD

Name: _____

Signature: _____

Position: _____

Date: _____

- Board President (for approvals)
- Chief/Deputy Chief/Executive Director (for ratifications)

Name: Dr. Denise Saddler

Signature: _____

Position: Superintendent and Secretary, Board of Education

Date: _____

Template approved as to form by OUSD Legal Department.



February 18, 2026

Culinary Depot
3325 W Sunset Rd Suite E Las Vegas, NV 89118

Subject: Renewal of RFP 26-162NS

Dear ,

The Oakland Unified School District Food & Nutrition Services is requesting to amend RFP 26-162NS for renewal for the upcoming 2026-2027 school year with Culinary Depot. Please fill out, sign and return this letter, including a price increase list (if applicable), no later than Wednesday, March 4, 2026, so that we may recommend for Board Approval.

Price Update Details:

- No price increase Price increase of _____% applied to all items
 Variable price increases. Vendor to provide detailed price list with response.

Included as Exhibit B are additional items available to bid for RFP 26-162NS. Please review and include with your response if applicable.

If you indicated a price increase, please provide a brief (1-2 sentence) justification:

Although no price increases are expected, we cannot hold prices for the year due to economic concerns. Due to these units being custom pieces, made to order, we would quote the units at the time of request from the district.

Accept renewal of contract RFP 26-162NS commencing on July 1, 2026 and ending on June 30, 2027.

Reject the renewal of contract RFP 26-162NS.

Culinary Depot

Company Name

Daniel Paredes

Authorized Company Representative Signature

Daniel Paredes

Print Name

3/2/2026

Date

Board Office Use: Legislative File Info.	
File ID Number	25-2728
Introduction Date	12/10/25
Enactment Number	25-1970
Enactment Date	12/10/2025 er



Board Cover Memorandum

To Board of Education

From Denise G. Saddler, EdD, Interim Superintendent
Preston Thomas, Chief Systems and Services Officer
Devinder Kumar, Senior Executive Director, Nutrition Services Department

Meeting Date December 10, 2025

Subject Request for Award of RFP #26-162NS Service Line Equipment Services and Approval of Agreement with Culinary Depot

Ask of the Board Approval by the Board of Education to award bid RFP #26-162NS Service Line Equipment Services K-12 Meal Program and services agreement by and between the District and Culinary Depot, Spring Valley, NY, for the latter to deliver Service Line Equipment Services for the period of November 1, 2025 through June 30, 2026, in an amount not-to-exceed \$400,000.00 with two (2) one-year options to renew, effective July 1 through June 30, upon further approval of the Board.

Background and Discussion The Nutrition Services Department provides meals to all students under California Universal Meals as defined in California Education Code section 49501.5. The District has an agreement with the California Department of Education Nutrition Services Division to provide meals under the National School Lunch and the Child and Adult Care Food Program. Service Line Equipment Services are needed to ensure Nutrition Services can serve meals in an efficient and timely manner and maintain food at proper safe temperatures during meal service. Service Line Equipment Services are necessary for these programs. On August 29, 2025, Nutrition Services advertised a Request for Proposal (RFP) #26-162NS. Eight vendors responded to the RFP. Culinary Depot was evaluated and selected on the following criteria: price, delivery time frame, recovered materials, service reliability and performance, small business status, and minority-owned business status.

Fiscal Impact Funding resource(s): 5310 Child Nutrition School Program in an amount not to exceed \$400,000.00

Attachment(s)

- Notice of Intent to Award RFP #26-162NS
- Culinary Depot Services Agreement 2025-2026
- Culinary Depot RFP #26-162NS Service Line Equipment Services Response
- RFP #26-162NS Service Line Equipment Services K-12 Meal Program for Nutrition Services



**OAKLAND UNIFIED
SCHOOL DISTRICT**
Community Schools, Thriving Students

NOTICE OF INTENT TO AWARD

October 23, 2025

TO: Culinary Depot

PROJECT:

**Request for Proposal (RFP) #26-162NS
SERVICE LINE EQUIPMENT K-12 MEAL PROGRAM
FOR NUTRITION SERVICES**

The Oakland Unified School District ("OUSD") ("District") has completed its RFP for Service Line Equipment..

OUSD intends to award Culinary Depot. The recommendation to award the bid to Culinary Depot, will be submitted to our District's Board of Education for final approval.

We thank you for participating in this bidding process and we look forward to working with you and your company.

IMPORTANT: Please reply with the contact person who will oversee the contract process, our team will reach out to discuss details and next steps.

To view additional bids, please visit our [Procurement Webpage](#).

Sincerely,

Rosaura M. Altamirano

Senior Manager, Supply Chain & Logistics

rosaura.altamirano@ousd.org

Procurement Department

900 High Street, Oakland, CA 94601

(510) 879-2990 ph.

SERVICES AGREEMENT

This Services Agreement (“AGREEMENT”) is a legally binding contract entered into between the Oakland Unified School District (“OUSD”) and the entity or individual (“VENDOR,” together with OUSD, “PARTIES”) named in **Exhibit A**, attached hereto and incorporated herein by reference. Unless otherwise stated herein, “VENDOR INDIVIDUAL” includes (to the extent they exist): VENDOR Board members, officers, trustees, and directors; VENDOR employees, agents, consultants, contractors and subcontractors, representatives, and other similar individuals; and volunteers and others unpaid persons under VENDOR’s direction, invitation, or control.

The PARTIES hereby agree as follows:

1. **Services.** VENDOR shall provide the services (“SERVICES”) as described in **Exhibit A**. 2.

Term. The term (“TERM”) of this AGREEMENT is established in **Exhibit A**.

3. **Compensation.**

- a. Over the TERM, OUSD agrees to pay VENDOR the amount of money stated in **Exhibit A** for satisfactorily performing the SERVICES. OUSD shall not pay and shall not be liable to VENDOR for any costs or expenses paid or incurred by VENDOR not described in **Exhibit A**.
- b. Compensation for SERVICES performed outside of the TERM (e.g., prior to execution of this AGREEMENT or after its termination) shall be at OUSD’s sole discretion and in an amount solely determined by OUSD. VENDOR agrees that it shall not expect or demand compensation for the performance of such SERVICES.
- c. VENDOR acknowledges and agrees not to expect or demand compensation for any SERVICES performed prior to the PARTIES, particularly OUSD, validly and properly executing this AGREEMENT and VENDOR shall not rely on verbal or written communication from any individual, other than the OUSD Superintendent or the OUSD Legal Counsel, stating that OUSD has validly and properly executed this AGREEMENT.
- d. Payment for SERVICES shall be made for all undisputed amounts no more frequently than in monthly installment payments within sixty (60) days after VENDOR submits an invoice to OUSD, in accordance with Paragraph 4 (Invoicing), for the SERVICES actually performed and after OUSD’s written approval that the SERVICES were actually performed. The granting of any payment by OUSD, or the receipt thereof by VENDOR, shall in no way lessen the liability of VENDOR to correct unsatisfactory performance of SERVICES, even if the unsatisfactory character of the performance was not apparent or detected at the time a payment was made. If OUSD determines that VENDOR’s performance does not conform to the requirements of this AGREEMENT, VENDOR agrees to correct its performance without delay.

- 4. Invoicing.** Invoices furnished by VENDOR under this AGREEMENT must be in a form acceptable to OUSD.
- a. All amounts paid by OUSD shall be subject to audit by OUSD. Invoices shall include, without limitation: VENDOR name, VENDOR address, invoice date, invoice number, purchase order number, name of school or department to which the SERVICES were provided, name(s) of the person(s) performing the SERVICES, date(s) the SERVICES were performed, brief description of the SERVICES provided on each date, total invoice amount, and the basis for the total invoice amount (e.g., if hourly rate, the number of hours on each date and the rate for those hours).
 - b. If OUSD, at its sole discretion, determines an invoice fails to include the required elements, OUSD will not pay the invoice and will inform VENDOR of the missing items; VENDOR shall resubmit an invoice that includes the required elements before OUSD will pay the invoice.
 - c. Invoices must be submitted no more frequently than monthly, and within 30 days of the conclusion of the applicable billing period. OUSD reserves the right to refuse to pay untimely invoices.
 - d. OUSD reserves the right to add or change invoicing requirements. If OUSD does add or change invoicing requirements, it shall notify VENDOR in writing and the new or modified requirements shall be mandatory upon receipt by VENDOR of such notice.
 - e. To the extent that VENDOR has described how the SERVICES may be provided both in-person and not in-person, VENDOR's invoices shall—in addition to any invoice requirement added or changed under subparagraph (d)—indicate whether the SERVICES were provided in-person or not.
 - f. All invoices furnished by VENDOR under this AGREEMENT shall be delivered to OUSD via email unless OUSD requests, in writing, a different method of delivery.
- 5. Suspension.** If OUSD, at its sole discretion, develops health and safety concerns related to VENDOR's provision of SERVICES, then the OUSD Superintendent or an OUSD Chief may, upon approval by OUSD legal counsel, issue a notice to VENDOR to suspend this AGREEMENT, in which case VENDOR shall stop providing SERVICES under this AGREEMENT until further notice from OUSD. OUSD shall compensate VENDOR for the SERVICES satisfactorily provided through the date of suspension.
- 6. Termination.** Upon termination consistent with this Paragraph (Termination), VENDOR shall provide OUSD with all data and materials produced, maintained, or collected by VENDOR pursuant to this AGREEMENT, whether or not such materials are complete or incomplete or are in final or draft form.
- a. For Convenience by OUSD. OUSD may at any time terminate this AGREEMENT upon thirty (30) days prior written notice to VENDOR. OUSD shall compensate VENDOR for SERVICES satisfactorily provided through the date of termination. Upon approval by OUSD legal counsel, the OUSD Superintendent or an OUSD Chief may issue the termination notice without prior approval by the OUSD

Governing Board, in which case this AGREEMENT would terminate upon ratification of the termination by the OUSD Governing Board or thirty (30) days after the notice was provided, whichever is later. VENDOR shall immediately stop providing SERVICES upon receipt of the termination notice from the OUSD Superintendent or OUSD Chief.

- b. For Cause. Either PARTY may terminate this AGREEMENT by giving written notice of its intention to terminate for cause to the other PARTY. Written notice shall contain the reasons for such intention to terminate, which shall include (i) material violation of this AGREEMENT or (ii) if either PARTY is adjudged bankrupt, makes a general assignment for the benefit of creditors, or a receiver is appointed on account of its insolvency. Upon approval by OUSD legal counsel, the OUSD Superintendent or an OUSD Chief may issue the termination notice without prior approval by the OUSD Governing Board, in which case this AGREEMENT would terminate upon ratification of the termination by the OUSD Governing Board or three (3) days after the notice was provided, whichever is later, unless the condition or violation ceases or satisfactory arrangements for its correction are made. VENDOR shall immediately stop providing SERVICES upon receipt of the termination notice from the OUSD Superintendent or OUSD Chief.
- c. Due to Unforeseen Emergency or Acts of God. Notwithstanding any other language of this AGREEMENT, if there is an unforeseen emergency or an Act of God during the TERM that would prohibit or limit, at the sole discretion of OUSD, the ability of VENDOR to perform the SERVICES, OUSD may terminate this AGREEMENT upon seven (7) days prior written notice to VENDOR. The OUSD Governing Board may issue this type of termination notice or the OUSD Superintendent, upon approval by OUSD legal counsel, may issue this type of the termination notice without the need for approval or ratification by the OUSD Governing Board. VENDOR shall immediately stop providing SERVICES upon receipt of the termination notice from the OUSD Superintendent.
- d. Due to Failure to Ratify by OUSD Board. If, consistent with Paragraph 41 (Signature Authority), this AGREEMENT is executed on behalf of OUSD by the signature of the Superintendent, a Chief, a Deputy Chief, or an Executive Director, and the Board thereafter declines to ratify this AGREEMENT, this AGREEMENT shall automatically terminate on the date that the Board declines to ratify it. OUSD shall compensate VENDOR for the SERVICES satisfactorily provided through the date of termination.

7. Data and Information Requests.

- a. VENDOR shall timely provide OUSD with any data and information OUSD reasonably requests related to the provision of the SERVICES.
- b. VENDOR shall register with and maintain current information within OUSD's Community Partner database unless OUSD communicates to VENDOR in writing otherwise, based on OUSD's determination that the SERVICES are not related to community school outcomes. If and when VENDOR's programs and school site(s)

change (either midyear or in subsequent years), VENDOR shall promptly update the information in the database.

8. Confidentiality and Data Privacy.

- a. OUSD may share information with VENDOR pursuant to this AGREEMENT in order to further the purposes thereof. VENDOR and VENDOR INDIVIDUALS shall maintain the confidentiality of all information received in the course of performing the SERVICES, provided such information is (i) marked or identified as “confidential” or “privileged,” or (ii) reasonably understood to be confidential or privileged.
- b. VENDOR understands that student data is confidential. VENDOR or VENDOR INDIVIDUALS may only access or receive identifiable student data, other than directory information, in connection with this AGREEMENT only after VENDOR and OUSD execute (i) a California Student Data Privacy Agreement (“CSDPA”) or CSDPA Exhibit E, if VENDOR is a software vendor, or (ii) the OUSD Data Sharing Agreement, if VENDOR is not a software vendor. Notwithstanding Paragraph 24 (Indemnification), should VENDOR or VENDOR INDIVIDUALS access or receive identifiable student data, other than directory information, without first executing such an agreement, VENDOR shall be solely liable for any and all claims or losses resulting from its access or receipt of such data.
- c. All confidentiality requirements, including those set forth in the separate data sharing agreement, extend beyond the termination of this AGREEMENT.

- 9. Copyright/Trademark/Patent/Ownership.** Except for any intellectual property owned by VENDOR that existed prior to execution of this AGREEMENT, VENDOR understands and agrees that all other matters produced under this AGREEMENT shall be works for hire as defined under Title 17 of the United States Code, and all copyrights in those works are the property of OUSD. These matters include, without limitation, drawings, plans, specifications, studies, reports, memoranda, computation sheets, the contents of computer diskettes, artwork, copy, posters, billboards, photographs, videotapes, audiotapes, systems designs, software, reports, diagrams, surveys, source codes or any other original works of authorship, or other documents prepared by VENDOR in connection with the SERVICES performed under this AGREEMENT. VENDOR cannot use, reproduce, distribute, publicly display, perform, alter, remix, or build upon matters produced under this AGREEMENT without OUSD’s express written permission. OUSD shall have all right, title and interest in said matters, including the right to register the copyright, trademark, and/or patent of said matter in the name of OUSD. OUSD may, with VENDOR’s prior written consent, use VENDOR’s name in conjunction with the sale, use, performance and distribution of the matters, for any purpose and in any medium.

10. Alignment and Evaluation.

- a. VENDOR agrees to work and communicate with OUSD staff, both formally and informally, to ensure that the SERVICES are aligned with OUSD's mission and are meeting the needs of students as determined by OUSD.
- b. OUSD may evaluate VENDOR or VENDOR INDIVIDUALS in any reasonable manner which is permissible under the law. OUSD's evaluation may include, without limitation: (i) requesting that OUSD employee(s) evaluate the performance of VENDOR or VENDOR INDIVIDUALS, and (ii) announced and unannounced observance of VENDOR or VENDOR INDIVIDUALS.

11. Inspection and Approval. VENDOR agrees that OUSD has the right and agrees to provide OUSD with the opportunity to inspect any and all aspects of the SERVICES performed including, but not limited to, any materials (physical or electronic) produced, created, edited, modified, reviewed, or otherwise used in the preparation, performance, or evaluation of the SERVICES. In accordance with Paragraph 3 (Compensation), the SERVICES performed by VENDOR must meet the approval of OUSD, and OUSD reserves the right to direct VENDOR to redo the SERVICES, in whole or in part, if OUSD, in its sole discretion, determines that the SERVICES were not performed in accordance with this AGREEMENT.

12. Equipment and Materials. VENDOR shall provide all equipment, materials, and supplies necessary for the performance of this AGREEMENT.

13. Legal Notices. Based on contact information set forth in **Exhibit A**, all legal notices provided for under this AGREEMENT shall be sent via email and either (i) personally delivered during normal business hours or (ii) sent by U.S. Mail (certified, return receipt requested) with postage prepaid to the other PARTY. Notice shall be effective when received if personally served or emailed or, if mailed, three days after mailing. Either PARTY must give written notice of a change of mailing address or email.

14. Status.

- a. This is not an employment contract. VENDOR, in the performance of this AGREEMENT, shall be and act as an independent contractor.
- b. If VENDOR is a natural person, VENDOR verifies all of the following: (i) VENDOR is free from the control and direction of OUSD in connection with VENDOR's work; (ii) VENDOR's work is outside the usual course of OUSD's business; and (iii) VENDOR is customarily engaged in an independently established trade, occupation, or business of the same nature as that involved in the work performed for OUSD.
- c. If VENDOR is a business entity, VENDOR understands and agrees that it and any and all VENDOR INDIVIDUALS shall not be considered employees of OUSD, and are not entitled to benefits of any kind or nature normally provided employees of OUSD and/or to which OUSD's employees are normally entitled, including, but not limited to, State Unemployment Compensation or Worker's Compensation.

VENDOR shall assume full responsibility for payment of all Federal, State, and local taxes or contributions, including unemployment insurance, social security and income taxes with respect to VENDOR INDIVIDUALS. VENDOR verifies all of the following:

- (i) VENDOR is free from the control and direction of OUSD in connection with the performance of the work;
- (ii) VENDOR is providing the SERVICES directly to OUSD rather than to customers of OUSD;
- (iii) the contract between OUSD and VENDOR is in writing;
- (iv) VENDOR has the required business license or business tax registration, if the work is performed in a jurisdiction that requires VENDOR to have a business license or business tax registration;
- (v) VENDOR maintains a business location that is separate from the business or work location of OUSD;
- (vi) VENDOR is customarily engaged in an independently established business of the same nature as that involved in the work performed;
- (vii) VENDOR actually contracts with other businesses to provide the same or similar services and maintains a clientele without restrictions from OUSD; (viii) VENDOR advertises and holds itself out to the public as available to provide the same or similar services;
- (ix) VENDOR provides its own tools, vehicles, and equipment to perform the SERVICES;
- (x) VENDOR can negotiate its own rates;
- (xi) VENDOR can set its own hours and location of work; and
- (xii) VENDOR is not performing the type of work for which a license from the Contractor's State License Board is required, pursuant to Chapter 9 (commencing with section 7000) of Division 3 of the Business and Professions Code.

15. Qualifications, Training, and Removal.

- a. VENDOR represents and warrants that VENDOR and all VENDOR INDIVIDUALS have the necessary and sufficient experience, qualifications, and ability to perform the SERVICES in a professional manner, without the advice, control or supervision of OUSD. VENDOR will perform the SERVICES in accordance with generally and currently accepted principles and practices of its profession for services to California school districts and in accordance with applicable laws, codes, rules, regulations, and/or ordinances.
- b. VENDOR represents and warrants that all VENDOR INDIVIDUALS are specially trained, experienced, competent and fully licensed to provide the SERVICES identified in this AGREEMENT in conformity with the laws and regulations of the State of California, the United States of America, and all local laws, ordinances and/or regulations, as they may apply.
- c. VENDOR agrees to immediately remove or cause the removal of any VENDOR INDIVIDUAL from OUSD property upon receiving notice from OUSD of such

desire. OUSD is not required to provide VENDOR with a basis or explanation for the removal request.

16. **Certificates/Permits/Licenses/Registration.** VENDOR shall ensure that all VENDOR INDIVIDUALS secure and maintain in force such certificates, permits, licenses, and registration as are required by law in connection with the furnishing of the SERVICES pursuant to this AGREEMENT.

17. **Insurance.**

a. **Commercial General Liability Insurance.** VENDOR shall maintain Commercial General Liability Insurance, including automobile coverage, with limits of at least one million dollars (\$1,000,000) per occurrence, and two million dollars (\$2,000,000) aggregate, sexual misconduct, harassment, bodily injury and property damage. Coverage for sexual misconduct and harassment may either be provided through General Liability Insurance or Professional Liability Insurance. The coverage shall be primary as to OUSD and shall name OUSD as an additional insured with the additional insured endorsement provided to OUSD within 15 days of effective date of this AGREEMENT (and within 15 days of each new policy year thereafter during the TERM). Evidence of insurance shall be attached to this AGREEMENT or otherwise provided to OUSD upon request. Endorsement of OUSD as an additional insured shall not affect OUSD's rights to any claim, demand, suit or judgment made, brought or recovered against VENDOR. The policy shall protect VENDOR and OUSD in the same manner as though each were separately issued. Nothing in said policy shall operate to increase the Insurer's liability as set forth in the policy beyond the amount or amounts shown or to which the Insurer would have been liable if only one interest were named as an insured. The requirements of this subparagraph may be specifically waived as noted in **Exhibit A**.

b. **Workers' Compensation Insurance.** VENDOR shall procure and maintain, at all times during the TERM of this AGREEMENT, Workers' Compensation Insurance in conformance with the laws of the State of California (including, but not limited to, Labor Code section 3700) and Federal laws when applicable. Employers' Liability Insurance shall not be less than one million dollars (\$1,000,000) per accident or disease. The requirements of this subparagraph may be specifically waived as noted in **Exhibit A**.

18. **Testing and Screening.**

a. **Tuberculosis Screening.** VENDOR shall ensure that all VENDOR INDIVIDUALS who will be working at OUSD sites for more than six hours in total during the TERM or who work with students (regardless of the length of time) have submitted to a tuberculosis risk assessment as required by Education Code section 49406 within the prior 60 days. If tuberculosis risk factors were identified for a VENDOR INDIVIDUAL, that VENDOR INDIVIDUAL must submit to an intradermal or other approved tuberculosis examination to determine if that VENDOR INDIVIDUAL is

free of infectious tuberculosis. If the results of the examination are positive, VENDOR shall obtain an x-ray of the lungs. VENDOR, at its discretion, may choose to submit a VENDOR INDIVIDUAL to the examination instead of the risk assessment. The requirements of this subparagraph may be specifically waived as noted in **Exhibit A**.

- b. Fingerprinting/Criminal Background Investigation. For all VENDOR INDIVIDUALS providing the SERVICES, VENDOR shall ensure completion of fingerprinting and criminal background investigation and shall request and regularly review subsequent arrest records. VENDOR confirms that no VENDOR INDIVIDUAL providing the SERVICES has been convicted of a felony, as that term is defined in Education Code section 45122.1. VENDOR shall provide the results of the investigations and subsequent arrest notifications to OUSD. For purposes of this subparagraph, VENDOR shall use either California Department of Justice or Be A Mentor, Inc. (<http://beamentor.org/OUSDPartner>) finger-printing and subsequent arrest notification services. The requirements of this subparagraph may be specifically waived as noted in **Exhibit A**.

19. Incident/Accident/Mandated Reporting.

- a. VENDOR shall notify OUSD, via email pursuant to Paragraph 13 (Legal Notices), within twelve (12) hours of learning of any significant accident or incident in connection with the provision of the SERVICES. Examples of a significant accident or incident include, without limitation, an accident or incident that involves law enforcement, or possible or alleged criminal activity, or possible or actual exposure to a communicable disease such as COVID-19. VENDOR shall properly submit required accident or incident reports within one business day pursuant to the procedures specified by OUSD. VENDOR shall bear all costs of compliance with this Paragraph.
- b. To the extent that a VENDOR INDIVIDUAL is included on the list of mandated reporters found in Penal Code section 11165.7, VENDOR agrees to inform that VENDOR INDIVIDUAL, in writing, that they are a mandated reporter, and describing the associated obligations to report suspected cases of abuse and neglect pursuant to Penal Code section 11166.5.

20. Health and Safety Orders and Requirements; Site Closures.

- a. VENDOR shall adhere to any health or safety orders or requirements issued at the time of the execution of this AGREEMENT or in the future by OUSD or other public entities ("Orders").
- b. Except as possibly stated otherwise in **Exhibit A**, VENDOR is able to meet its obligations and perform the SERVICES required pursuant to this AGREEMENT in accordance with any Order; to the extent that VENDOR becomes unable to do so, VENDOR shall immediately inform OUSD in writing.
- c. Except as possibly stated otherwise in **Exhibit A**, to the extent that there may be a site closure (e.g., due to poor air quality, planned loss of power, strike) or similar event in which school sites and/or District offices may be closed or

otherwise inaccessible, VENDOR is able to meet its obligations and perform the SERVICES required pursuant to this AGREEMENT; to the extent that VENDOR becomes unable to do so, VENDOR shall immediately inform OUSD in writing.

- d. VENDOR shall bear all costs of compliance with this Paragraph, including but not limited lost compensation for failure to provide SERVICES.

21. Conflict of Interest.

- a. VENDOR and all VENDOR INDIVIDUALS shall abide by and be subject to all applicable regulations, statutes, or other laws regarding conflict of interest. VENDOR shall not hire, contract with, or employ any officer or employee of OUSD during the TERM without the prior approval of OUSD Legal Counsel.
- b. VENDOR affirms, to the best of his/her/its knowledge, that there exists no actual or potential conflict of interest between VENDOR's family, business, or financial interest and the SERVICES provided under this AGREEMENT, and in the event of any change in either private interest or the SERVICES under this AGREEMENT, any question regarding a possible conflict of interest which may arise as a result of such change will be immediately brought to OUSD's attention in writing.
- c. Through its execution of this AGREEMENT, VENDOR acknowledges that it is familiar with the provisions of section 1090 *et seq.* and section 87100 *et seq.* of the Government Code, and certifies that it does not know of any facts which constitute a violation of said provisions. In the event VENDOR receives any information subsequent to execution of this AGREEMENT which might constitute a violation of said provisions, VENDOR agrees it shall immediately notify OUSD in writing.

22. Certification Regarding Debarment, Suspension, Ineligibility and Voluntary Exclusion.

VENDOR certifies, to the best of its knowledge and belief, that it and its principals are not presently debarred, suspended, proposed for debarment, declared ineligible, or voluntarily excluded from covered transactions by any Federal department or agency according to Federal Acquisition Regulation Subpart 9.4, and by signing this AGREEMENT, certifies that neither it nor its principals appear on the Excluded Parties List (<https://www.sam.gov/>).

23. Limitation of OUSD Liability. Other than as provided in this AGREEMENT, OUSD's financial obligations under this AGREEMENT shall be limited to the compensation described in Paragraph 3 (Compensation). Notwithstanding any other provision of this AGREEMENT, in no event shall OUSD be liable, regardless of whether any claim is based on contract or tort, for any special, consequential, indirect or incidental damages, including, but not limited to, lost profits or revenue, arising out of, or in connection with, this AGREEMENT for the SERVICES performed in connection with this AGREEMENT.

24. Indemnification.

- a. To the furthest extent permitted by California law, VENDOR shall indemnify, defend and hold harmless OUSD, its Governing Board, agents, representatives, officers, consultants, employees, trustees, and volunteers (“OUSD Indemnified Parties”) from any and all claims or losses accruing or resulting from injury, damage, or death of any person or entity arising out of VENDOR’s performance of this AGREEMENT. VENDOR also agrees to hold harmless, indemnify, and defend OUSD Indemnified Parties from any and all claims or losses incurred by any supplier or subcontractor furnishing work, services, or materials to VENDOR arising out of the performance of this AGREEMENT. VENDOR shall, to the fullest extent permitted by California law, defend OUSD Indemnified Parties at VENDOR’s own expense, including attorneys’ fees and costs, and OUSD shall have the right to accept or reject any legal representation that VENDOR proposes to defend OUSD Indemnified Parties.
 - b. To the furthest extent permitted by California law, OUSD shall indemnify, defend, and hold harmless VENDOR and VENDOR INDIVIDUALS from any and all claims or losses accruing or resulting from injury, damage, or death of any person or entity arising out of OUSD’s performance of this AGREEMENT. OUSD shall, to the fullest extent permitted by California law, defend VENDOR and VENDOR INDIVIDUALS at OUSD’s own expense, including attorneys’ fees and costs.
25. **Audit.** VENDOR shall establish and maintain books, records, and systems of account, in accordance with generally accepted accounting principles, reflecting all business operations of VENDOR transacted under this AGREEMENT. VENDOR shall retain these books, records, and systems of account during the TERM and for three (3) years after the earlier of (i) the TERM or (ii) the date of termination. VENDOR shall permit OUSD, its agent, other representatives, or an independent auditor to audit, examine, and make excerpts, copies, and transcripts from all books and records, and to make audit(s) of all billing statements, invoices, records, and other data related to the SERVICES covered by this AGREEMENT. Audit(s) may be performed at any time, provided that OUSD shall give reasonable prior notice to VENDOR and shall conduct audit(s) during VENDOR’S normal business hours, unless VENDOR otherwise consents.
26. **Non-Discrimination.** It is the policy of OUSD that, in connection with all work performed under legally binding agreements, there be no discrimination because of race, color, ancestry, national origin, religious creed, physical disability, medical condition, marital status, sexual orientation, gender, or age; therefore, VENDOR agrees to comply with applicable Federal and California laws including, but not limited to, the California Fair Employment and Housing Act beginning with Government Code section 12900 and Labor Code section 1735 and OUSD policy. In addition, VENDOR agrees to require like compliance by all its subcontractor (s). VENDOR shall not engage in unlawful discrimination in employment on the basis of actual or perceived: race, color, national origin, ancestry, religion, age, marital status, pregnancy, physical or mental disability, medical condition, veteran status, gender, sex, sexual orientation, or other legally protected class.

27. **Compliance with California and Federal Laws.** VENDOR shall comply with all applicable California and Federal laws, regulations, and ordinances. This includes, but is not limited to, compliance with the California Labor Code 6401.9 (Workplace Violence Prevention Plans), as well as any other laws related to labor, employment, safety, health, and environmental regulations. The VENDOR shall ensure that all activities and services conducted under this AGREEMENT are in strict compliance with such laws and regulations. Any violation of these laws, regulations, or ordinances by the VENDOR or any of its employees, subcontractors, volunteers, or agents shall constitute a material breach of this AGREEMENT.
28. **Drug-Free/Smoke Free Policy.** No drugs, alcohol, and/or smoking are allowed at any time in any buildings and/or grounds on OUSD property. No students, staff, visitors, VENDORS, or subcontractors are to use controlled substances, alcohol or tobacco on these sites.
29. **Waiver.** No delay or omission by either PARTY in exercising any right under this AGREEMENT shall operate as a waiver of that or any other right or prevent a subsequent act from constituting a violation of this AGREEMENT.
30. **Assignment.** The obligations of VENDOR under this AGREEMENT shall not be assigned by VENDOR without the express prior written consent of OUSD and any assignment without the express prior written consent of OUSD shall be null and void.
31. **No Rights in Third Parties.** This AGREEMENT does not create any rights in, or inure to the benefit of, any third party except as expressly provided herein.
32. **Litigation.** This AGREEMENT shall be deemed to be performed in Oakland, California and is governed by the laws of the State of California, but without resort to California's principles and laws regarding conflict of laws. The Alameda County Superior Court shall have jurisdiction over any litigation initiated to enforce or interpret this AGREEMENT.
33. **Incorporation of Recitals and Exhibits.** Any recitals and exhibits attached to this AGREEMENT are incorporated herein by reference. VENDOR agrees that to the extent any recital or document incorporated herein conflicts with any term or provision of this AGREEMENT, the terms and provisions of this AGREEMENT shall govern.
34. **Integration/Entire Agreement of Parties.** This AGREEMENT constitutes the entire agreement between the PARTIES and supersedes all prior discussions, negotiations, and agreements, whether oral or written. This AGREEMENT may be amended or modified only by a written instrument executed by both PARTIES.
35. **Severability.** If any term, condition, or provision of this AGREEMENT is held by a court of competent jurisdiction to be invalid, void or unenforceable, the remaining provisions will

nevertheless continue in full force and effect, and shall not be affected, impaired or invalidated in any way.

- 36. Provisions Required By Law Deemed Inserted.** Each and every provision of law and clause required by law to be inserted in this AGREEMENT shall be deemed to be inserted herein and this AGREEMENT shall be read and enforced as though it were included therein.
- 37. Captions and Interpretations.** Paragraph headings in this AGREEMENT are used solely for convenience, and shall be wholly disregarded in the construction of this AGREEMENT. No provision of this AGREEMENT shall be interpreted for or against a PARTY because that PARTY or its legal representative drafted such provision, and this AGREEMENT shall be construed as if jointly prepared by the PARTIES.
- 38. Calculation of Time.** For the purposes of this AGREEMENT, “days” refers to calendar days unless otherwise specified and “hours” refers to hours regardless of whether it is a work day, weekend, or holiday.
- 39. Counterparts and Electronic Signature.** This AGREEMENT, and all amendments, addenda, and supplements to this AGREEMENT, may be executed in one or more counterparts, all of which shall constitute one and the same amendment. Any counterpart may be executed and delivered by facsimile or other electronic signature (including portable document format) by either PARTY and, notwithstanding any statute or regulations to the contrary (including, but not limited to, Government Code section 16.5 and the regulations promulgated therefrom), the counterpart shall legally bind the signing PARTY and the receiving PARTY may rely on the receipt of such document so executed and delivered electronically or by facsimile as if the original had been received. Through its execution of this AGREEMENT, each PARTY waives the requirements and constraints on electronic signatures found in statute and regulations including, but not limited to, Government Code section 16.5 and the regulations promulgated therefrom.
- 40. W-9 Form.** If VENDOR is doing business with OUSD for the first time, VENDOR acknowledges that it must complete and return a signed W-9 form to OUSD.
- 41. Agreement Publicly Posted.** This AGREEMENT, its contents, and all incorporated documents are public documents and will be made available by OUSD to the public online via the Internet.
- 42. Signature Authority.**
- a. Each PARTY has the full power and authority to enter into and perform this AGREEMENT, and the person(s) signing this AGREEMENT on behalf of each PARTY has been given the proper authority and empowered to enter into this AGREEMENT.

b. Notwithstanding subparagraph (a), VENDOR acknowledges, agrees, and understands (i) that only the Superintendent, and the Chiefs, Deputy Chiefs, and Executive Directors who have been delegated such authority, may validly sign contracts for OUSD and only under limited circumstances, and (ii) that all such contract still require ratification by the OUSD Governing Board. VENDOR agrees not to accept the signature of another other individual as having the proper authority to enter into this AGREEMENT on behalf of OUSD.

43. **Contract Contingent on Governing Board Approval.** The PARTIES acknowledge, agree, and understand that OUSD shall not be bound by the terms of this AGREEMENT unless and until it has been (i) formally approved by OUSD's Governing Board or (ii) validly and properly executed by the OUSD Superintendent, a Chief, or a Deputy Chief authorized by the Education Code or Board Policy, and no compensation shall be owed or made to VENDOR absent such formal approval or valid and proper execution.

REST OF PAGE INTENTIONALLY LEFT BLANK

IN WITNESS WHEREOF, the PARTIES hereto agree and execute this AGREEMENT and to be bound by its terms and conditions:

VENDOR

Name: Daniel Paredes Signature: *Daniel Paredes*

Position: Government Sales Date: 10/28/2025

One of the terms and conditions to which VENDOR specifically agrees by its signature is subparagraph (c) of Paragraph 3 (Compensation), which states that VENDOR acknowledges and agrees not to expect or demand compensation for any SERVICES performed prior to the PARTIES, particularly OUSD, validly and properly executing this AGREEMENT and shall not rely on verbal or written communication from any individual, other than the OUSD Superintendent or OUSD Legal Counsel, stating that OUSD has validly and properly executed this AGREEMENT.

OUSD

Name: Jennifer Brouhard Signature: *Jennifer Brouhard*

Position: President, Board of Education Date: 12/10/2025

- Board President (for approvals)
- Chief/Deputy Chief/Executive Director (for ratifications)

Name: Denise G. Saddler Signature: *Denise G. Saddler*

Position: Interim Superintendent and Interim Secretary, Board of Education

Date: 12/10/2025

Template Approved as to form by OUSD Legal Department

**SERVICES AGREEMENT
EXHIBIT A**

(Each Listed Clause below Corresponds to the Clause in the Agreement.)

VENDOR: Culinary Depot

Clause 1: **Services.** Describe the SERVICES VENDOR will provide: Culinary Depot will partner with OUSD Nutrition Services to procure and deliver Refrigerated Serving Wells, Heated Speedline, and Cash Register Stands in quantities to be ordered during the term of the contract in quantities to be determined and ordered as need by the District.

Clause 2: **Term.**

a. This AGREEMENT shall start on the below Start Date. If no date is entered, then this AGREEMENT shall start on the latest of the dates on which each of the PARTIES signed this AGREEMENT.

Start Date: November 1, 2025

b. Unless terminated earlier, this AGREEMENT shall end on the below End Date. If no date is entered, then this AGREEMENT shall end on the first June 30 after the start date listed in subparagraph (a). If the dates set forth in this subparagraph and subparagraph (a) would cause this AGREEMENT to exceed the limits set forth in state law (e.g., Education Code section 17596), this AGREEMENT shall instead automatically end upon reaching said limit.

End date: June 30, 2026

Clause 3: **Compensation.**

a. The basis for payment to VENDOR shall be:

- Hourly Rate: _____ per hour
- Daily Rate: _____ per day
- Weekly Rate: _____ per week
- Monthly Rate: _____ per month
- Per Student Served Rate: _____ per student served
- Performance/Deliverable Payments: Describe below the performance

and/or deliverable(s) as well as the associated rate(s): Payments shall be made within 30 days of receipt of invoice for delivered Refrigerated Serving Wells, Heated Speedline or Cash Register Stands. Quantities and prices to be specified on Purchase Order(s). _____

b. Over the TERM, the total compensation under this AGREEMENT shall not exceed the below amount. This sum includes (but is not limited to) compensation for the full performance of this AGREEMENT and all fees, costs, and expenses incurred by VENDOR including (but not limited to) labor, materials, taxes, profit, overhead, travel, insurance, permitted subcontractor costs, and other costs.

Not-To-Exceed Amount: \$400,000

NOTE: Each Listed Clause below Corresponds to the Clause in the Agreement

Clause 13: **Legal Notices.**

OUSD

Site/Dept: Legal Department
Address: 1011 Union Street, Site 946
City, ST Zip: Oakland, CA 94607
Phone: 510-879-5060
Email: ousdlegal@ousd.org

VENDOR

Name/Dept: Chefs Depot Inc DBA Culinary Depot
Address: 67 Route 59
City, ST Zip: Spring Valley, NY, 10977
Phone: 888-845-8200 x 5897
Email: danielp@culinarydepot.com

Clause 17: **Insurance.** OUSD has waived the following insurance requirements. Written confirmation of a waiver (e.g., email from OUSD Risk Management Officer) is attached hereto. Failure to attach such written confirmation voids any such waiver even if otherwise properly given.

- Commercial General Liability Insurance.* Waiver typically available by OUSD if no VENDOR INDIVIDUAL interacts or has contact with OUSD students (in-person or virtual) and the not-to-exceed amount is \$25,000 or less.
- Workers' Compensation Insurance.* Waiver typically available by OUSD if VENDOR has no employees.

Clause 18: **Testing and Screening.** OUSD has waived the following testing and screening requirements. Written confirmation of a waiver (e.g., email from OUSD Risk Management Officer) is attached hereto. Failure to include such written confirmation voids any such waiver even if otherwise properly given.

- Tuberculosis Screening.* Waiver typically available by OUSD if VENDOR INDIVIDUALS will have no in-person contact with OUSD students.
- Fingerprinting/Criminal Background Investigation.* Waiver typically available by OUSD if no VENDOR INDIVIDUAL interacts or has contact with OUSD students (in-person or virtual).

Clause 20: **Health and Safety Orders and Requirements; Site Closures.** If there is an Order or event in which school sites and/or District offices may be closed or otherwise inaccessible, would the SERVICES be able to continue?

- Yes, the SERVICES would be able to continue as described herein.
- No, the SERVICES would not be able to continue.
- Yes, but the SERVICES would be different than described herein, they would be as follows:

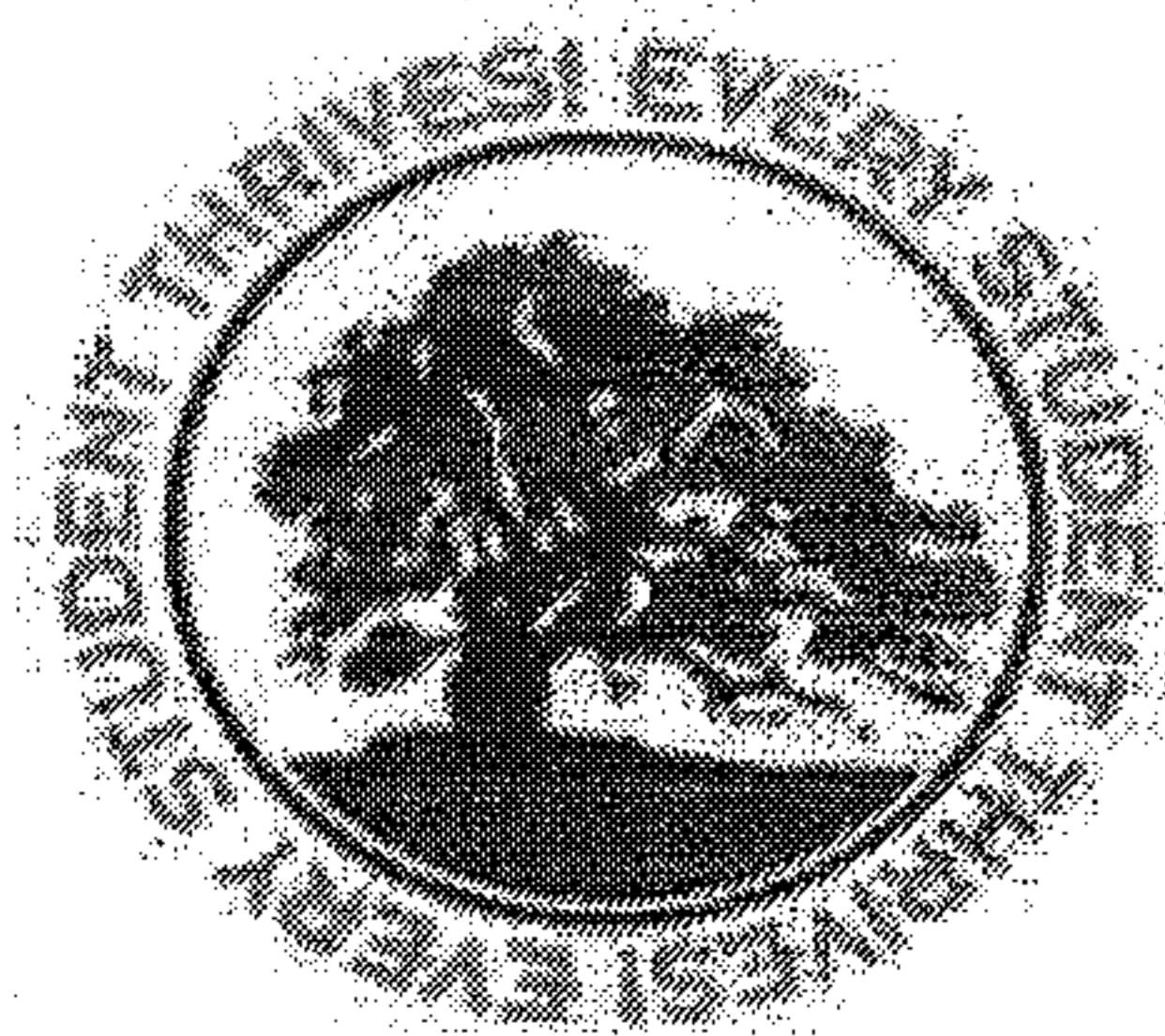

**OAKLAND UNIFIED
SCHOOL DISTRICT**
Community Schools, Thriving Students

Request for Proposal (RFP) #26-162NS

**SERVICE LINE EQUIPMENT
K-12 MEAL PROGRAM
FOR NUTRITION SERVICES**

**OAKLAND UNIFIED SCHOOL DISTRICT
Attention: Procurement Department
900 High Street, 2nd Floor
OAKLAND, CA 94601**

**email: procurement@ousd.org
phone: (510) 879-2990**

**Proposals Due:
September 30, 2025 at 2:00 PM PST**

THE TERMS AND CONDITIONS OF THIS RFP ARE GOVERNED BY
THE APPLICABLE STATE AND FEDERAL LAWS.

Table of Contents

Table of Contents	2
RFP Schedule Of Events	3
Notice to Bidders	4
General Information about the District	4
Introduction	4
Proposal Instructions and General Requirements	5
Pricing	6
District Evaluation/Selection Process	6
Protests Selection Procedure	7
Terms and Conditions	8
Delivery Requirements and Locations	15
Proposal Submission Instructions	17
Proposal Submission Checklist - Attachment "1"	18
Itemized Bid List-Attachment "2"	19
Request For Proposal Signature Page - Attachment "3"	24
The Evaluation Criteria-Attachment "4"	25
Vendor Questionnaire - Attachment "5"	27
References - Attachment "6"	29
Non Collusion Affidavit - Attachment "7"	31
Bidder's Statement Regarding Insurance Coverage - Attachment "8"	32
Workers' Compensation Insurance Certificate - Attachment "9"	33
Drug-Free Workplace Certification - Attachment "10"	34
Equal Opportunity Employment - Attachment "11"	35
Fingerprinting/Criminal Background Investigation Certification - Attachment "12"	36
Certificate of Independent Price Determination - Attachment "13"	42
Suspension And Debarment Certification - Attachment "14"	43
Certification Regarding Lobbying - Attachment "15"	45
Iran Contracting Act Of 2010 Compliance Affidavit - Attachment "16"	48
Clean Air And Water Certification - Attachment "17"	50

RFP Schedule Of Events

The following schedule will be used by the District for this RFP.

DATE	ACTION
RFP Posting/First Advertisement:	August 29, 2025
Deadline for Questions:	September 18, 2025 @ 4:00 p.m. PST
Proposal/Bid Submitted to District:	September 30, 2025 @ 2:00 p.m. PST
Potential Interviews (If Necessary):	October 6-9, 2025
Final Bid Award Notice:	October 16, 2025
Contract Start Date:	November, 2025

OUSD will use every effort to adhere to the schedule. However, OUSD reserves the right to amend the schedule, as it deems necessary.

The District reserves the right to amend or cancel this proposal at any time. Proposers are responsible for viewing any new changes related to this proposal online at <https://www.ousd.org/bidopportunities>.

If a proposer desires any clarification or questions of any kind regarding this solicitation, the proposer must make a written request and should be addressed via email to:

Procurement Department
procurement@ousd.org

NOTE: Contacting Board members and/or any District staff other than the procurement analyst who is outlined above, may disqualify the proposer from the selection process.

Notice to Bidders

The Oakland Unified School District ("District") is requesting submission of statements of qualifications and proposals ("Proposals") from qualified persons, firms, partnerships corporations, associations or professional organizations ("Bidder(s)") for the provision and delivery of Food Service Supplies ("Products") to the District, as further described herein.

General Information about the District

The Oakland Unified School District (OUSD) is the eleventh largest school district in California. OUSD located in and is approximately coterminous with the City of Oakland, California, and is located on the east side of the San Francisco Bay, approximately 10 miles from San Francisco.

The Oakland Unified School District (District) operates under a locally-elected seven member Board form of government and provides educational services to grades CDC/Pre-K - Adult. The District operates twenty-eight (28) child development centers, forty-five (45) elementary schools, eleven (11) middle schools, nine (9) high schools, four (4) K-8, three (3) 6-12, six (6) alternative ed and other programs as well. The District serves approximately 34,700 students. We encourage you to visit our website (<http://www.ousd.org>) for more information about our District.

Introduction

The District has one (1) delivery site. The District is seeking Proposals from qualified companies to procure and deliver products. This RFP defines the Program (as defined below), the products and the services that are being sought from the Bidders and generally outlines the Program requirements.

Oakland Unified School District ("District") is seeking bids for purchase and delivery of Kitchen Equipment in quantities to be ordered during the term of the contract. Additionally, the District is seeking installation for service line equipment specified in the Purchase Specifications list.

This bid is for purchase by, and delivery to, the Oakland Unified School District (also referred to hereinafter in this document as the "District") of the items described in this bid package ("Items") during the term of the contract in quantities to be determined and ordered as needed by the District, all in accordance with the District's bid package documents for this contract, including but not limited to the Invitation for Bids, Purchase Specifications, Bid Form, Agreement Form, and Instructions to Bidders.

Proposal Instructions and General Requirements

Bidder Questions Regarding this Request for Proposals – Any questions regarding this Request for Proposals shall be **emailed** to the Oakland Unified Procurement Department at **procurement@ousd.org** prior to **September 18, 2025 at 2:00 pm PST** deadline.

Deadline for Receipt of RFPs – Proposals must be submitted via **email** to the District no later than the date and time specified in the RFP. Late submissions will not be considered. Proposals must be complete and signed; unsigned proposals will be rejected. Once the submission deadline has passed, all proposals will be reviewed and evaluated based on pricing, specifications, and other relevant criteria. No award decisions will be made at the time of opening.

The RFP – All numbers on the bid should be stated in figures, and signatures of all individuals must be in long-hand. Unsigned Proposals will not be accepted. FAX copies of Proposals will not be accepted for formal advertised RFPs.

Responsibility – Bidders are solely responsible for ensuring their Proposal is received by the District in accordance with the solicitation requirements before the date and time specified in the RFP, and at the place specified. The District shall not be responsible for any delays in mail or by common carriers or by transmission errors or delays or mistaken delivery.

Drug Free Workplace Certificate – In accordance with California Government Code §§8350 et seq., the Drug Free Workplace Act of 1990, the Successful Bidder will be required to execute a Drug Free Workplace Certificate concurrently with execution of the Agreement. The Successful Bidder will be required to implement and take the affirmative measures outlined in the Drug Free Workplace Certificate and in California Government Code §§8350 et seq. Failure of the Successful Bidder to comply with the measures outlined in the Drug Free Workplace Certificate and in California Government Code §§8350 et seq. may result in penalties, including without limitation, the termination of the Agreement, the suspension of any payment of the Contract Price otherwise due under the Contract Documents and/or debarment of the Successful Bidder.

Term of Contract – Minimum contract term is one (1) year. Quoted prices must stay in effect for twelve (12) months after award of RFP and may be extended upon mutual consent of Oakland Unified School District and vendor for two (2) additional one (1) year periods in accordance with provisions contained in the Education Code, Sections 17596. If extended, price increases may be negotiated **subject to existing local market conditions, and as determined by the California Consumer Price Index (CPI) with prior District consent.** In the event of a general price decrease the District reserves the right to revoke the RFP award unless the decrease is passed on to the District.

Pricing

Provide a detailed Statement of Pricing for Products to be provided. Bidder shall provide evidence and documentation of cost (at invoice price) to the District upon the District's request. Errors in price computations will not excuse Bidder from holding price.

Pricing Terms – Contract prices awarded for fixed price items shall remain firm for the contract period. Prices proposed for all items will be for the period July 1, 2025, through June 30, 2026. All orders placed by the District will be delivered and invoiced at the Agreement price regardless of the actual delivery date. Proposers must agree to fix contract fees for the first year. If the organization intends to revise its fee schedule after the initial one-year period, it must give written notice to the District 90 days in advance of any fee change. Fees may be changed only on the contract expiration date with 90 days notice. These fees are subject to negotiation and approval by the District.

Itemized Bid List – The District's Itemized Bid Lists is attached hereto.

Modifications of Contracted Price Lists to Acquire Additional Goods or Increase Quantities of Listed Goods – Items not included in the executed contract can be added only if all of the following conditions are met: The total value of all added goods and quantities of listed goods does not exceed the limit specified in the original solicitation and contract. If the value of additional goods exceeds the specified limit, a separate procurement for those goods must be conducted or these purchases will be considered an unallowable cost. The USDA recommends limiting the additional costs to 10 percent of the estimated value of the contract.

All Other Costs or Fees – Pricing information for, without limitation, transactional services, additional services, Bidder's mark-up on subconsultant and subcontractor prices, general conditions, and all other categories of costs, expenses, fees, or charges that Bidder anticipates will be a part of its price to provide the Products.

District Evaluation/Selection Process

Basis for Selection – The responsiveness, competency and responsibility of Bidders and of their proposed subcontractors will be considered in making the award of contract. Any Bidder before being awarded a contract may be required to furnish evidence to the District that the Bidder has sufficient means and experience in the type of work called for to assure completion of the contract in a satisfactory manner. The District reserves the right to reject the Proposal of any Bidders as not responsible and not qualified to provide the products under consideration who have previously failed to perform properly or to complete on time contracts with the District of a nature similar to this procurement. A responsive Proposal is one that meets all terms, conditions, and specifications of the Proposal. The award of this solicitation is conditional on the winning bidder accepting the terms of the contract available to view online at <https://www.ousd.org/procurement/bid-opportunities/current-bid-opportunities>.

A Proposal which substantially conforms, though not strictly responsive, to a call for Proposals may be accepted if the variance cannot have affected the amount of the Proposal or given a Bidder an advantage or benefit not allowed to other Bidders. or, in other words, if the variance is inconsequential.

The District reserves the right to reject any and all Proposals or alternatives and waive any informality or irregularity in the Proposals or in the bidding, and to determine responsiveness and responsibility of Bidder, including but not limited to those areas mentioned above. The District makes no representation that participation in the RFP process will lead to an award of contract or any consideration whatsoever.

Evaluation/Award – The District intends to select one of the Bidders—but reserves the right to select no Bidder or more than one Bidder—that best meet(s) the District’s needs to provide the Products as described in this RFP. From the Bidders that provide Proposals to the District, the District may, at its discretion, interview some or all of those Bidders. One or more Bidders may be selected (“Successful Bidder”). The Successful Bidder will be selected based on qualifications and demonstrated competence that include relevant experience with public agencies, including local agencies, and a proven track record of success for these types of Products. Proposals will be evaluated separately and will be awarded to one or more Bidders based on the highest scored Proposal. The Evaluation Criteria, Descriptions, and Point Scoring are listed in Attachment 4. The contract awarded through this bid will be non-exclusive, meaning that the District may purchase, at its discretion, food service supplies from other vendors throughout the contract if it deems necessary.

Previous Performance – Bidders are advised that the District reserves the right to reject a Proposal from a Bidder that cannot demonstrate the ability to provide the goods or services required. Bidders who have demonstrated unsatisfactory performance may be subject to disqualification as a responsible Bidder submitting a Proposal, thereby disqualifying the Bidder from contract award.

Protests Selection Procedure

Any Bidder may protest the Districts issuance of a notice of “Not To Award” if it believes that the District has incorrectly selected another proposer for the award. Notice of protest shall be filed with the District within five (5) business days after the notice of “Not to Award” is received. The notice of protest must include the name of the protesting bidder, a detailed description of specific grounds for protest, and copies of all supporting documents. Provider should submit the protest electronically by email to:

Rosaura M. Altamirano
Senior Manager, Supply Chain & Logistics
rosaura.altamirano@ousd.org

The protest must contain a complete statement of any and all bases for the protest.

The protest must refer to the specific portions of any documents that form the bases for the protest.

The party filing the protest must concurrently transmit a copy of the protest and any attached documentation to all other parties with a direct financial interest that may be adversely affected by the outcome of the protest, and all other Bidders who appear to have a reasonable prospect of receiving an award depending upon the outcome of the protest.

The procedure and time limits set forth in this paragraph are mandatory and are each Bidder's sole and exclusive remedy in the event of protest. Failure to comply with any of these procedures, at the District's sole discretion, shall constitute a waiver of any right to further pursue the protest, including filing a Government Code Claim or legal proceedings.

Terms and Conditions

In addition to the following, this RFP is subject to the terms of the Contract attached and included herewith.

Acceptance of Proposals – The District reserves the right to reject any or all Proposals and to select individual items. Proposals may be rejected on grounds of non-responsiveness or non-responsibility. The District does **NOT** guarantee that all items shown on this Proposal will be purchased. The right is reserved to purchase additional quantities at the Proposal prices during the contract period. It is not intended that large variations from the listed quantities will be made, but quantity additions or deletions shall be at the option of the District. The District reserves the right to reject any or all Proposals or waive any irregularities or informalities in any Proposals or in the bidding.

Alteration of Request for Proposal Text – Changes in or additions to the Request for Proposal, as well as any attachments, amendments or other official correspondence related to this Request for Proposal may not be manually, electronically or otherwise altered by Bidder or Bidder's agent(s). Recapitulations of the Products proposed upon, alternative Proposals, or any other modification of the Request for Proposal which is not specifically called for in the award agreement documents may result in the District's rejection of the Proposal as not being responsive to the Request for Proposal. No oral or telephonic modification of any Proposal submitted will be considered and a telegraphic modification may be considered only if the postmark evidences that a confirmation of the telegram duly signed by the Bidder was placed in the mail prior to the opening of Proposals.

Anti-discrimination – Bidder shall certify that it is an Equal Opportunity Employer and has made a good faith effort to improve employment of people from historically disadvantaged groups and agrees to meet Federal and State guidelines. No discrimination shall be made in the employment of persons upon public works in this project because of the sex, race, color, national origin or ancestry, religion, or handicap of such personnel.

Authorized Distributor – Successful Bidder must be an Authorized Distributor for the product offered, or with Bidder's quote, Bidder must submit documentation from an Authorized Distributor from whom Bidder has purchased the specified materials.

Proposal Negotiations – A Proposal response to any specific item of this Request for Proposal with terms such as "negotiable," "will negotiate," or similar, will be considered non-responsive to that specific item.

California Public Records Act – Responses to this RFP will become the property of the District and subject to the California Public Records Act, Government Code sections 7920.000 et seq. Those elements in each response that are trade secrets as that term is defined in Civil Code section 3426.1(d) or otherwise exempt by law from disclosure and which are prominently marked as "TRADE SECRET," "CONFIDENTIAL," or "PROPRIETARY" may not be subject to disclosure. The District shall not be liable or responsible for the disclosure of any such records including, without limitation, those so marked if disclosure is deemed to be required by law or by an order of the Court. A Bidder that indiscriminately identifies all or most of its response as exempt from disclosure without justification may be deemed non-responsive. In the event the District is required to defend an action on a Public Records Act request for any of the contents of a response marked "Confidential," "Proprietary," or "Trade Secret," the Bidder agrees, by submission of its response for the District's consideration, to defend, hold harmless, and indemnify the District from all costs and expenses, including attorneys' fees, in any action or liability arising under the Public Records Act.

Cancellation of Solicitation – The District may cancel this solicitation at any time.

Clarification, Corrections or Changes to Specifications – All clarifications, corrections, or changes to the solicitation documents will be made by Addendum only. Bidders shall not rely upon interpretations, corrections, or changes made in any other manner, whether by telephone, in person, or in email. Interpretations, corrections, and changes shall not be binding unless made by the Addendum. All Addenda issued shall become part of the Agreement documents. Addenda will be sent to all known solicitation holders by email or U.S. mail. It is the Bidder's sole responsibility to ascertain that it has received all Addenda issued for this solicitation. All Addenda must be acknowledged and returned on or before the Submittal Deadline, unless otherwise directed by an Addendum.

Competency of Bidders Submitting a Proposal – A proposal will only be accepted from, or contract awarded to, a contractor who is licensed in accordance with the law, to

whom a proposal form has been issued by the District and who has successfully performed on projects of similar character and scope to the proposed work. A representative of the District, prior to contract award may examine the business premises of any Bidder submitting a Proposal. Bidders submitting a Proposal shall agree to fully comply with all City, State and Federal laws, regulations and ordinances governing performance of an awarded contract. It will be the responsibility of the contractor to obtain any clearances necessary for completion of the contract.

Compliance with OSHA – Bidder agrees that all item(s) offered comply with all applicable Federal and the State Occupational Safety and Health Act, laws, standards and regulations, and that Bidder will indemnify and hold the District harmless for any failure to so conform.

Cost of Proposal Preparation – Cost of preparation of the response to this RFP is solely the responsibility of the Bidder submitting a Proposal. The District accepts or implies no liability in the cost of preparation.

Definitions – Responsible: a bidding party possessing the skill, judgment, qualifications, integrity and financial ability necessary to timely perform and complete the contract being bid. Responsive: a Proposal which meets all of the specifications set forth in the RFP.

District Requirements – The quantity shown is the estimate of consumption for the contract period. The needs of the District may be substantially more or less than such referenced quantities. The articles, supplies or services listed in the RFP and required during the contract period shall be ordered and purchased from the Successful Bidder(s) during such period. The District shall have the right to issue purchase orders up to and including the last day of the contract period even though the time provided for delivery may extend beyond such period.

Errors and Corrections – The Proposal submitted must not contain any erasures, interlineations, or other corrections unless each such correction creates no inconsistency and is suitably authenticated by signatures/initials of the person or persons signing the Proposal. Correction of any such errors shall be made prior to the Proposal opening only. In the event of inconsistency between words and figures in the Proposal price, words shall control figures. In the event that the District determines that any Proposal is unintelligible, inconsistent or ambiguous, the District may reject such Proposal as not being responsive. The Proposal cannot be corrected after the Proposal opening.

Examination of Proposal Documents – Bidders submitting a Proposal shall thoroughly examine and be familiar with the specifications. The failure or omission of any Bidder submitting a Proposal to receive or examine any Proposal document(s), forms, instruments, Addendum or other document there existing shall in no way relieve any Bidder submitting a Proposal from obligations with respect to this RFP or to the

contract. The submission of a Proposal shall be taken as prima facie evidence of compliance with this section.

Examination of Locations – It shall be the responsibility of the Successful Bidder to establish knowledge of the District and the specific delivery locations to familiarize him/herself with the access and egress, construction or building difficulties and method of delivery, all of which could affect the Successful Bidders ability to service the District. It shall be the responsibility of the Successful Bidder to cope with all these eventualities.

Failure to Comply with Instructions – Failure to comply with any of the instructions stated in the Proposal documents may result in rejection of the Proposal.

Any party submitting a Proposal shall not contact, or lobby any District Board member, official, employee, agent or representative during the Bidding process including up to the date of Board action, except as specified in the Proposal for contact. Any party attempting to influence the Proposal including the submittal, review process and awarding of the Proposal will have their Proposal rejected for violating this term and condition of the RFP.

Any party, individual, group or firm, not submitting a Proposal, but which may have a financial or business interest in the award of the Proposal shall not contact or lobby any District Board member, official, employee, agent, contractor or representative, including up to the date of Board action. Any and all public comment regarding the Board's action in the award of this Proposal will be accepted on the date of Board action in a public meeting pursuant to the Brown Act.

FOB Destination Pricing – All shipments shall be made FOB destination, Oakland, California FOB destination indicates that the seller is responsible for shipment until it is tendered to the District. The District will not pay for shipping and handling, nor shall the District pay for any fuel surcharges that are not indicated herein. If the material is not received within the time specified for delivery, it will be received at the discretion of the District. Should it be necessary to refuse delivery of any material contained in the Proposal document, the Bidder shall be responsible for the cost of retrieving the merchandise in question.

Formation of Contract – Bidder's signed Proposal and District's written acceptance with approval from the District's Governing Board shall constitute a binding contract.

Contract Term - It is the intent to award the contract for an initial one (1) year period with the option to renew it for two (2), one-year periods for a possible total contract term of 3 years. The decision to renew the contract(s) will be at the sole discretion of the District and agreed upon by both parties.

Insurance Requirements – Successful Bidder shall maintain insurance as specified in the Section titled, "Minimum Insurance/Coverage." Successful Bidder must furnish the District with the Certificates of Insurance proving coverage as specified in the section titled, "Minimum Insurance/Coverage" and naming the District Additional Insured by

endorsement within ten (10) calendar days. Failure to furnish the required certificates within the time allowed may result in withdrawal of award.

Packing, Crating, Cartage – The cost of all special packing, boxing, crating, or cartage shall be included in the pricing specified on the response unless otherwise specifically stated in the District's request. Damaged cases or packages may be rejected and returned for credit or immediate replacement, at no cost to the District for product or freight. All costs for containers shall be borne by the vendor.

Recovered Materials – In compliance with edition 6002 of the Solid Waste Disposal Act the District shall procure only items designated in the guidelines of the Environmental Protection Agency (EPA) at 40 CFR part 247 that contain the highest percentage of recovered materials practicable, consistent with maintaining a satisfactory level of competition, where the purchase price of the item exceeds \$10,000 or the value of the quantity acquired during the preceding fiscal year exceeded \$10,000.

40 CFR part 247 defines Recovered Material as waste materials and byproducts which have been recovered or diverted from solid waste, but such term does not include those materials and byproducts generated from, and commonly reused within an original manufacturing process.

Contracting With Minority Owned Businesses – Per CFR 200.321 the District will provide consideration for contracting with a bidder that is a minority or women owned business. CFR 4.62 defines a minority or women owned business as "...at least 51 percent unconditionally-owned by one or more members of a minority group or by one or more women..."

Contracting With Small Businesses – Per CFR 200.321 the District will provide consideration for contracting with a bidder that falls under the definition of small business provided in the Health and Safety Code 23395.20: " "Small business" means an independently owned and operated business, that is not dominant in its field of operation, that, together with affiliates, has 100 or fewer employees, and that has average annual gross receipts of ten million dollars (\$10,000,000) or less over the past three years."

Payment – (a) Bidder shall state payment terms offered. (b) Payment will be made on the pay period after receipt and acceptance of goods and/or services and upon department confirmation of such acceptance.

Post Award Meeting – Prior to performing any work or providing any services specified on this Contract, the Successful Bidder may be required to meet with the District's Nutrition Services Department for the purpose of reviewing the products and services offered herein, determining milestones regarding the District's expectations, and to discuss any issues related to the execution of this RFP. The Successful Bidder shall perform all work in accordance with such schedule pursuant to the Terms & Conditions

of this RFP and the awarded Contract. The District will approve all materials associated with this RFP.

Right to Inspect Successful Bidder Facilities – The District reserves the right to inspect the Successful Bidder's facilities prior to award of contract and/or during the term of the contract and if representatives of the District determine after such inspection that the Successful Bidder is not capable of performance satisfactory to the District, the Proposal will not be considered or the Agreement can be canceled.

Substitutions – All Bidders must conform to the specifications set forth in these Proposal documents. The District reserves the right to reject all Proposals that do not conform to the specifications. Do not use "as specified" in responding to this requirement. At a minimum, descriptive technical literature fully describing the claimed "as equal" product must be attached to the Proposal. Suitability and valuation of "equal" rests in the sole discretion of the District.

Taxes – No Proposal shall include Federal Excise Tax, as the District is exempt from such tax and will furnish appropriate tax exemption certificates. The Successful Bidder shall pay all taxes, levies, duties and assessments of every nature due in connection with any work under the contract, shall make any and all payroll deductions required by law, and shall indemnify and hold harmless the District from any liability on account of any and all such taxes, levies, duties, assessments and deductions.

Terms of the Offer – The District's acceptance of Bidder's offer shall be limited to the terms herein unless expressly agreed in writing by the District.

Tobacco-Free Environment – All District sites have been designated as tobacco-free environments. Smoking and the use of tobacco products is prohibited at all times on all areas of District property. District property includes school buildings, school grounds, school owned vehicles and vehicles owned by others while on District property.

Withdrawal of Proposal – Any claim by a Bidder of error in its Proposal must be made in compliance with section 5100 et seq. of the Public Contract Code. The Bidders may withdraw Proposals only by written request received by the District's Nutrition Services Department Interim Executive Director (or Executive Director if instated).

Customer Service – The District requires that the successful Bidder have a dedicated account manager working with The District on a consistent basis.

Minimum Insurance/Coverage: The Bidder agrees to purchase and maintain through the duration of the contract insurance or liability coverage (such as liability coverage provided by a Joint Powers Agency) ensuring their ability to meet their respective defense and indemnity obligations set forth above. Such insurance or liability coverage shall have a limit of liability of no less than \$1,000,000 per claim/occurrence, and \$2,000,000 in the aggregate. For the acts and activities contemplated by this agreement, at a minimum, the following shall be provided:

1. **Commercial General Liability Insurance:** Bidder shall maintain at its expense a policy of commercial general liability insurance, endorsed to include professional liability coverage relative to the scope of service performed by Bidder. Such insurance shall be maintained in a company or companies lawfully authorized to do business in California as admitted carriers so designated by the California Department of Insurance. It is preferred that such carriers will have a financial rating of at least "A,11" status as rated in the most recent edition of Best's Insurance Reports or as amended agreement between the District and Bidder. All policies shall contain a provision requiring thirty (30) days written notice to be given to the District prior to cancellation, modification, or reduction of limits.
2. **Additional Insured Endorsement:** Oakland Unified School District, its elected and appointed officers, agents, employees, volunteers, Bidders and representatives shall be listed as Additional Insured as respects the operations of the named insured. Coverage shall not be limited to the vicarious liability or supervisory role of any additional insured. Said insurance policy shall be endorsed (copy of Endorsement attached to Certificate of Insurance) to include the following language, "Oakland Unified School District, its elected and appointed officers, agents, employees, volunteers, Bidders and representatives shall be listed as Additional Insured as respects the operations of the named insured performed under the terms of this Agreement."
3. **Primary Insurance Endorsement:** In addition to the "Additional Insured" as stated above, said insurance policy shall be endorsed (copy of Endorsement attached to Certificate of Insurance) to include the following language, "Such insurance as is afforded by the Endorsement for the Additional Insured's shall apply as primary insurance. Any other insurance maintained by the District, its elected and appointed officers, agents, employees, Bidders and representatives shall be excess only and not contributing with the insurance afforded by this Endorsement."
4. **Certificate of Insurance:** Prior to commencing services pursuant to this Agreement, Bidder shall provide certificates as evidence of the existence of the insurance required by this Agreement, on insurance certificates executed by a duly-authorized agent of Bidder's insurance provider. Such certificates shall include the Endorsements described in this Agreement as attachments.
5. **Workers' Compensation:** Bidder shall provide Workers' Compensation coverage as required by California law, and in signing this Agreement, makes the following certification: "Bidder is aware of the provisions of Section 3700 of the Labor Code which require every employer to be insured against liability for Workers' Compensation or to undertake self-insurance in accordance with such provisions before commencing the performance of this Agreement." Prior to commencing services pursuant to this Agreement, Bidder shall provide a certificate indicating the existence of Workers' Compensation coverage as required by this

Agreement, on an insurance certificate executed by a duly-authorized agent of Bidder's insurance provider.

6. **Injury and Illness Prevention:** Bidder shall maintain and enforce an Injury and Illness Prevention Program as required by State law, and in signing this Agreement, makes the following certification: "Bidder is aware of the provisions of California Labor Code, Division 5, and of the California Code of Regulations, Title 8, and shall maintain an active Injury and Illness Prevention Plan in accordance with such provisions before commencing the performance of this Agreement." The Injury and Illness Prevention Plan shall be available to the District upon request
7. **Commercial Automobile Liability:** If Bidder is going to operate a vehicle on District property or transport students in any capacity. Limits of liability shall include a minimum of \$1,000,000 combined single limit.
8. **Survivability:** The parties' indemnity and coverage obligations shall survive the termination of this agreement with respect to any claim arising from the parties' actual or alleged performance or non-performance of their respective rights, privileges, or obligations existing under this agreement.
9. **Joint Interests:** In the event of a claim covered by these provisions, the Parties agree to take all steps reasonable or necessary to cooperate in defending and protecting their joint interests, including efforts to reduce defense costs (through joint representation whenever possible), expenses and potential liability exposures.

Delivery Requirements and Locations

Delivery Specifications -

1. The Successful Bidder will partner with the District over the term of the contract resulting from this RFP to procure and deliver Food Service Supplies to the District. The District reserves the rights to make additions to, or deletions from, the lists of school sites to be served at any time during the period of the contract, and revise delivery times as required. Awarded vendor(s) will be required to make direct deliveries to one (1) site. The site requires 1-2 days per week deliveries due to storage limitations or volume purchases and seeks a Bidder that can provide next day delivery for orders submitted before 2pm the previous day.
2. All deliveries shall occur between the hours of 5:00 a.m. and 10:00 a.m. pacific time. Overnight deliveries, or "Dark drops," will not be accepted. If a scheduled delivery day is a holiday, deliveries will occur on the next business day after the holiday.
3. Delivery to site must be completed within the designated delivery timeframe as indicated below. Delivery shall not be made so close to service time as to create concern by the school site.

4. District reserves the right to designate an alternate delivery location if the designated site is unable to receive deliveries for any reason. The District reserves the right to add or remove delivery sites as needed. The District also reserves the right to revise delivery times as required. Additional product and service requirements are outlined within the RFP.

OUSD Delivery Location		
Location	Address	Delivery Times
Warehouse Distribution Center	900 High Street Oakland, CA 94601	5:00 am - 10:00 am

Proposal Submission Instructions

Proposals shall be **emailed** to the Procurement Department at procurement@ousd.org no later than **September 30, 2025 at 2:00pm PST**.

Proposal shall be submitted with subject line:
“Response to RFP Proposal #25-162NS Service Line Equipment”

***When submitting your proposal, be sure to get a ticket number or confirmation email.** Proposals submitted via email should be submitted as PDF file format. PDF file size should be sufficient enough to send via email, the District does not assume responsibility if the PDF file is too large to email. If electronic submission is a factor, the District encourages hand delivery of the proposal directly to the **Procurement Department, 900 High Street 2nd Floor Oakland, CA 94601 between the hours of 9:00am - 2:00pm PST**. All proposals emailed or delivered after scheduled closing time for receipt of proposals will not be considered. Incomplete proposals may be deemed non-responsive and therefore not considered.

The District reserves the right to reject any or all proposals. Proposals and any other information submitted by respondents in response to this RFP shall become the property of the District. Notwithstanding any indication by Contractor of confidential contents, and with the exception of bona fide confidential information, contents of proposals are public documents subject to disclosure under the California Public Records Act after award. The District will not provide compensation to Contractors for any expenses incurred by the Contractors for proposal preparation or for any demonstration that may be made. Contractors submit proposals at their own risk and expense.

Local and Small Local Business Program

In order to provide economic opportunity for Oakland residents and businesses and stimulate economic development in Oakland, the District has implemented a Local, Small Local and Small Local Resident Business Enterprise Program (“Local Business Program”). The District encourages Local, Small and Small Local Resident Businesses to apply.

Contractors claiming preference as a **certified** Oakland Small Business must attach a copy of their certification letter to their bid. This RFP, and subsequent amendments and/or updates will be available at: <https://www.ousd.org/procurement>. **Contractors are responsible for checking this website for information and changes to this RFP.**

Proposal Submission Checklist - Attachment "1"

TO BE SUBMITTED WITH PROPOSAL

Bidder Name:

Chef's Depot Inc DBA Culinary Depot

This checklist must be submitted with Bidder's Proposal.

REQUIRED DOCUMENTS:

- Proposal Submission Checklist (Att. 1, this form)
- Itemized Bid List (Att. 2)
- Request for Proposal Signature Page (Att. 3)
- The Evaluation Criteria (Att. 4)
- Vendor Questionnaire (Att. 5)
- References (Att. 6)
- Non Collusion Affidavit (Att. 7)
- Bidder's Statement Regarding Insurance Coverage (Att. 8)
- Workers' Compensation Insurance Certificate (Att. 9)
- Drug-Free Workplace Certification (Att. 10)
- Equal Opportunity Employment (Att. 11)
- Fingerprinting/Criminal Background Investigation Certification (Att. 12)
- Certificate of Independent Price Determination (Att. 13)
- Suspension and Debarment Certification (Att. 14)
- Certificate Regarding Lobbying (Att. 15)
- Iran Contracting Act of 2010 Compliance Affidavit (Att. 16)
- Statement of Pricing (Include in your proposal)
- Clean Air and Water Certification (Att. 17)
- Addenda

Itemized Bid List-Attachment "2"

Please complete the itemized list below. If you are proposing equivalent items, describe them in the "Equivalent Item Proposed" column. All proposed items must be of equal or higher quality and compatibility with the items specified by the District.

Drawings provided following item list.

LINE ITEMS	EQUIVALENT ITEMS PROPOSED	ESTIMATED QUANTITIES	UNIT BID PRICES	ESTIMATED TOTAL BID PRICES
<p>Food Warming Equipment Co. Inc. Model No. 30B-R-31 (OR EQUIVALENT): Refrigerated Serving Wells. VOLTS: 120 Volts. CONTROL PANEL: Electronic Controller CASTERS: 6x3.5" Casters CUSTOMER SIDE: 12" Drop Down Tray Slide Shelf OPERATOR SIDE: 8" Drop Down SS Cutting Board MISC OPTIONS: Removable Decorative Panels, Exterior Cabinet Upgrade 18GA, Cold Plate (2) - Roll Bonded, Height to be 31".</p>		15	\$8,781.24	\$131,718.60
<p>Food Warming Equipment Co. Inc. Model No. 30B-31 Series (OR EQUIVALENT) Heated Speed Line VOLTS: 120 Volts</p>		15	\$8,298.54	\$124,478.10

<p>CONTROL PANEL: Mechanical Thermostat WATTS: TBD CUSTOMER SIDE: 12" Drop-Down Tray Slide Shelf OPERATOR SIDE: 8" Drop Down SS Cutting Board MISC OPTIONS: Removable Decorative Panels, Height to Be 31" WARRANTY: 2 Year Parts, 1 Year Labor</p>				
<p>Food Warming Equipment Co. Inc. Model No. CRS-31-31 Series (OR EQUIVALENT) Cash Register Stand MISC OPTIONS: 1.75" Diameter Hole For Cable, Height To Be 31", Depth to Be 38.5", Removable Decorative Panels Standard Packaging</p>		15	\$6,351.43	\$95,271.45

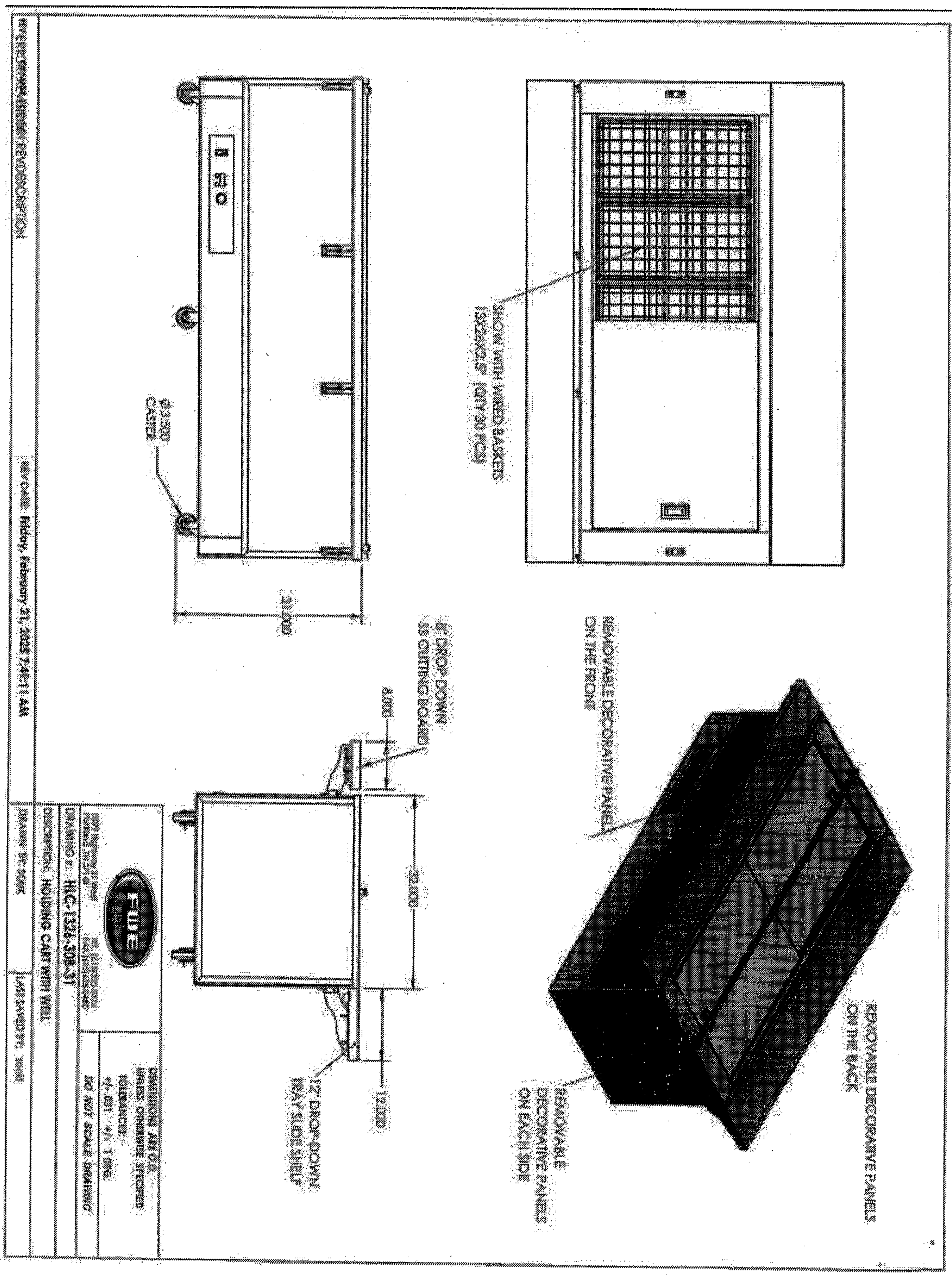

REVISED: MIDDAY, FEBRUARY 21, 2005 7:45:11 AM

DATE: 02/21/05

DATE: 02/21/05

DATE: 02/21/05

	
DIMENSION AREA HIGHER OR LOWER SPECIFIED TOLERANCES: +/- .001 +/- .1 INCH DO NOT SCALE DRAWING	
DISCREPANCY HOLDING CART WITH WHEEL	
DRAWING NO. HIC-1324-308-31	
DATE: 02/21/05	
DRAWING BY: [Name]	
CHECKED BY: [Name]	
APPROVED BY: [Name]	

MODEL H/C-132A-308-R-31
 SERIES REFRIGERATED SERVING WELLS
 VOLTS: 120 VOLTS
 ① CONTROL PANEL/ELECTRONIC CONTROLLER
 ② CATERVA 3.5" CASTERS
 ③ CUSTOMER SIDE 17" DROP-DOWN TRAY SIDE SHEET
 ④ OPERATOR SIDE 17" DROP-DOWN CUTTING BOARD
 AWC OPTIONS: ⑤ REMOVABLE DECORATIVE PANEL
 EXTERIOR CABINET UPGRADE 18 GA.

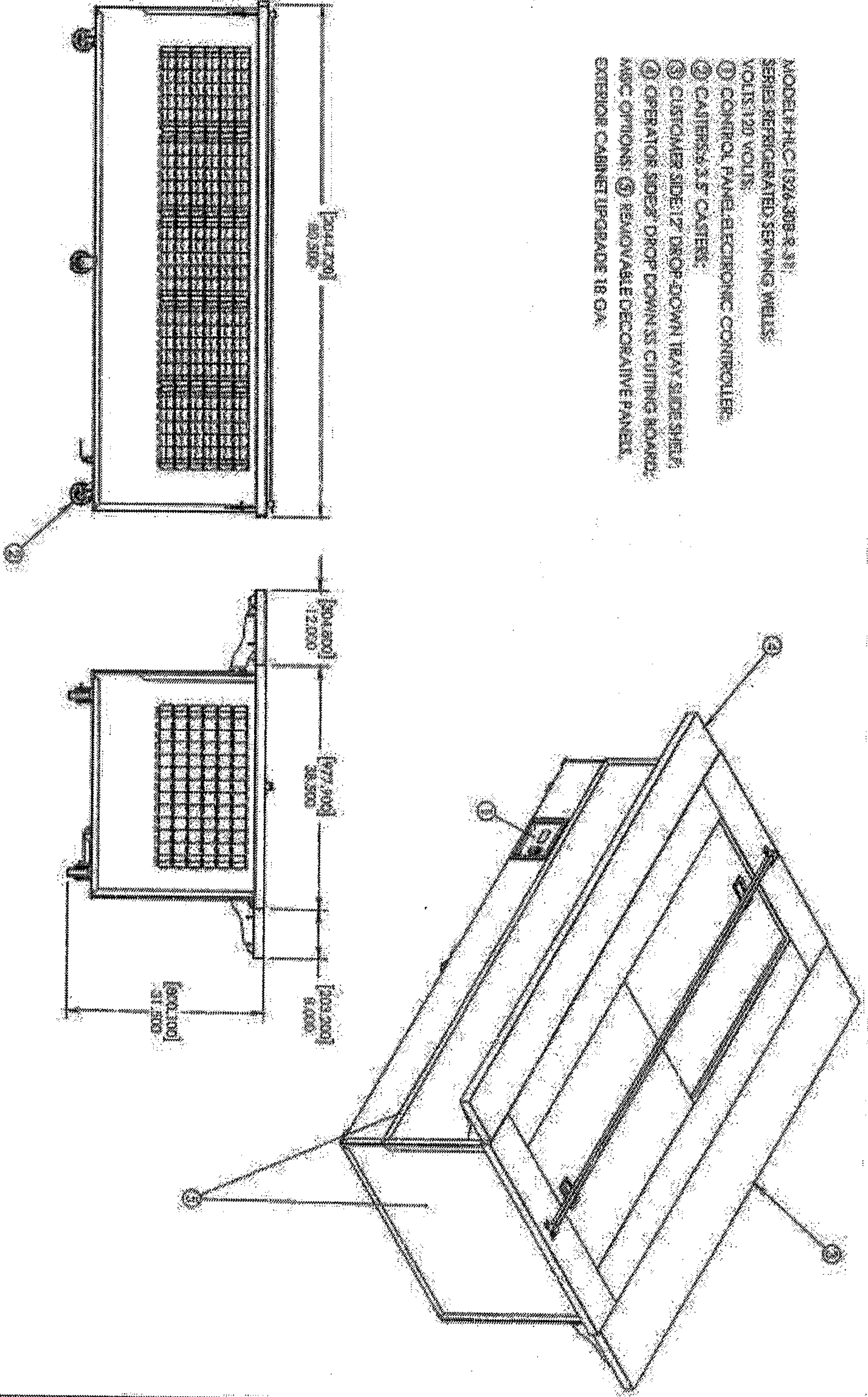

REV: LAST REV DATE: Friday, February 21, 2025 1:55:57 PM

APPROVAL:

	
H/C-132A-308-R-31	
DESCRIPTION: HOLDING CART WITH WELL	
LAST SAID BY: mshelton	
SERIAL DIMENSIONS ARE 0/16 UNLESS OTHERWISE NOTED TOLERANCES: DIMENSIONS SHOWN IN +/-.015 +/-.0100 mm±.005 DIM NOT SCALE DRAWING	SERIAL DIMENSIONS ARE 0/16 UNLESS OTHERWISE NOTED TOLERANCES: DIMENSIONS SHOWN IN +/-.015 +/-.0100 mm±.005 DIM NOT SCALE DRAWING

Request For Proposal Signature Page - Attachment "3"
TO BE SUBMITTED WITH PROPOSAL

By signing this, I certify that I am an authorized representative of the Bidder (or individual) and that information contained in this proposal is accurate, true, and binding upon the Bidder.	
Company Name	Chef's Depot Inc. DBA Culinary Depot
Signature of Company Official	
Name of Signer	Daniel Paredes
Title of Signer	Government Sales Rep
Email Address	danielp@culinarydepot.com
Complete Mailing Address	67 Route 59
City, State, Zip	Spring Valley, NY, 10977
Phone Number	845-414-5897
Date	9/26/2025
Minimum Dollar Amount for Delivery	\$
<input checked="" type="checkbox"/>	Check if no minimum dollar amount for delivery is required.
Minimum Case Amount for Delivery	
<input checked="" type="checkbox"/>	Check if no minimum case amount for delivery is required.

**The Evaluation Criteria-Attachment "4"
TO BE SUBMITTED WITH PROPOSAL**

Award Criteria	Description and. Points Awarded	Points Based On	Max Points
Price	100% of Max Points: Lowest-priced bid. 80% of Max Points: Second lowest-priced bid. 60% of Max Points: Third lowest-priced bid.	Itemized Bid Lists	25
Delivery Location	100% of Max Points: Ability to the Districts warehouse. 0 Points: Unable to the Districts warehouse.	- Reference forms - Responses to Questionnaire	15
Delivery Time Frame	100% of Max Points: Shortest Delivery Time 80% of Max Points: Second shortest Delivery Time 50% of Max Points: Third shortest Delivery Time 0 Points: 4th shortest or longer Delivery Time.	Responses to Questionnaire	15
Recovered Materials	100% of Max Points: The products quoted contain the highest percentage of recovered materials practicable (defined by 40 CFT part 247), consistent with maintaining a satisfactory level of competition. 0 Points: The products quoted do not contain the highest percentage of recovered materials practicable (defined by 40 CFT part 247), consistent with maintaining a satisfactory level of competition.	Response to Questionnaire	10
Service Reliability and Past Performance	100% of Max Points: Proven ability to provide excellent service as demonstrated by references & vendor questionnaire that show: -Prompt responses and satisfactory resolution to requests for information and complaints & issues -Courtesy and responsiveness to all district personnel at all times -Ready access to decision-making executives and assigned point of contact. 0 Points: References and/or vendor questionnaire that demonstrate poor performance or inability to meet criteria described above.	-Reference forms -Responses to Questionnaire	10

Contracting with Small Businesses	100% of Max Points: Qualifies as a small business. 0 Points: Does not qualify as a small business	Responses to Questionnaire	5
Contracting with Minority- Owned Businesses	100% of Max Points: Majority business ownership by individuals who identify as women or BIPOC (Black, Indigenous and People of Color). 0 Points: Majority business ownership not by individuals who identify as women or BIPOC.	Responses to Questionnaire	5
		TOTAL	85

By signing this, I acknowledge that I have reviewed OUSD's Evaluation Criteria.

Name of Bidder (Person, Firm, or Corporation): Chef's Depot Inc. DBA Culinary Depot

Signature of Bidder's Authorized Representative: 

Date of Signing: 9/26/2025

Vendor Questionnaire - Attachment "5"
TO BE SUBMITTED WITH PROPOSAL

Please complete this qualifying criteria questionnaire, use a separate sheet if necessary, and submit with your proposal.

1. Delivery - Are you able to deliver all items on the Item List to the Distribution Warehouse at 900 High Street Oakland, CA 94601? Yes No

2. Lead Time - What is the lead time for the items on the Item List from time of PO to delivery to the Distribution Warehouse? 12-14 Weeks

3. Recovered Materials - Do the products quoted contain the highest percentage of recovered materials practicable (defined by 40 CFT part 247), consistent with maintaining a satisfactory level of competition? Yes

4. Service Reliability and Past Performance - Will you be able to provide point/s of contact with whom the District can communicate through e-mail and by phone? Yes

5. Service Reliability and Past Performance - How many years has your company been in the Service Line Products business? 21 years

6. Service Reliability and Past Performance - Has your firm resigned or been replaced at the will of a district(s) during the school year within the last 36 months? If so, explain.
No

7. Service Reliability and Past Performance - During the previous school year how many K-12 schools districts did you service? 100+

8. Service Reliability and Past Performance - What is your procedure for notifying customers of a product recall? Please see attached form

9. Contracting with Small Businesses - Does your business meet the criteria of a small business as defined in CA Health and Safety Code Section 23395.20 ; "Small business" means an independently owned and operated business, that is not dominant in its field of operation, that, together with affiliates, has 100 or fewer employees, and that has average annual gross receipts of ten million dollars (\$10,000,000) or less over the past three years..."?
 - Yes
 - No

10. Contracting with Minority-Owned Businesses - per CFR 200.321: Does the majority (51% or more) of your business ownership identify as minority individual(s)?
 - Yes
 - No

In accordance with the contract documents, the undersigned propose to supply all of the product and perform all work specified in the contract documents in accordance with the proposal.

Name of Bidder (Person, Firm, or Corporation): Chef's Depot Inc. DBA Culinary Depot

Signature of Bidder's Authorized Representative:

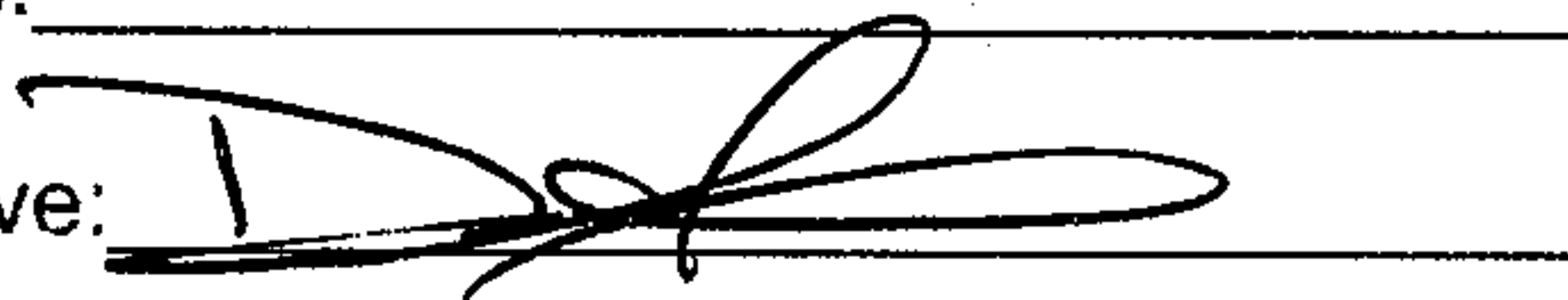

Date of Signing: 9/26/2025

Print Name & Title of Authorized Representative: Daniel Paredes - Government Sales Rep

Phone Number: 845-414-5897

Email: danielp@culinarydepot.com

References - Attachment "6"
TO BE SUBMITTED WITH PROPOSAL

Please submit three (3) current school district References requiring multiple deliveries per week. An unresponsive reference will **not** be considered a valid Reference. The Bidder is expected to exercise due diligence to ensure the References listed will be responsive to communications from the District.

Reference #1

School District	Westbrook Independent School District
Contact Person & Title	Shay Avants
Telephone Number	325-200-1645 shay.avants@westbrookisd.com
Required Number of Deliveries per Week	Delivered commercial kitchen equipment as needed

Reference #2

School District	Kenedy Independent School District
Contact Person & Title	Jo Deen Brown
Telephone Number	(830) 583-4100 ext 1559 jbrown@kenedyisd.com
Required Number of Deliveries per Week	Delivered commercial kitchen equipment as needed

Reference #3

School District	Cypress-Fairbanks ISD
Contact Person & Title	Stephanie Moore
Telephone Number	(281) 517-6552 stephanie.moore2@cfisd.net

Required Number of Deliveries per Week	Delivered commercial kitchen equipment as needed
---	---

Non Collusion Affidavit - Attachment "7"
PUBLIC CONTRACTS CODE SECTION 7106
TO BE SUBMITTED WITH PROPOSAL

State of California
County of Riverside

Bidder's Name Daniel Paredes, being first duly sworn, deposes and says that he or she is Owner of Contractor Name Chefs Depot Inc the party making the foregoing Proposal that the Proposal is not made in the interest of, or on behalf of, any undisclosed person, partnership, company, association, organization, or corporation; that the Proposal is genuine and not collusive or sham; that the Bidder has not directly or indirectly induced or solicited any other Bidder to put in a false or sham Proposal, and has not directly or indirectly colluded, conspired, connived, or agreed with any Bidder or anyone else to put in a sham Proposal, or that anyone shall refrain from bidding; that the Bidder has not in any manner, directly or indirectly, sought by agreement, communication, or conference with anyone to fix the Proposal price of the Bidder or any other Bidder, or to fix any overhead, profit, or cost element of the Proposal price, or of that of any other Bidder, or to secure any advantage against the public body awarding the contract of anyone interested in the proposed contract; that all statements contained in the Proposal are true; and further, that the Bidder has not, directly or indirectly, submitted his or her Proposal price or any breakdown thereof, or the contents thereof, or divulged information or data relative thereto, or paid, and will not pay, any fee to any corporation, partnership, company association, organization, Proposal depository, or to any member or agent thereof to effectuate a collusive or sham Proposal."

9/26/25

(Date)

Chefs Depot Inc

Bidder Name
(Person, Firm, Corp.)

67 Route 59

Address

Spring Valley, NY 10977

City, State, Zip

Temecula, CA

Signed at (Place)



Authorized Representative

Daniel Paredes

Representative's Name

Government Sales Rep

Representative's Title

Bidder's Statement Regarding Insurance Coverage - Attachment "8"

TO BE SUBMITTED WITH PROPOSAL

Bidder HEREBY CERTIFIES that the Bidder has reviewed and understands the insurance coverage requirements specified in the Request for Proposals. Should the Bidder be awarded the contract for the work, Bidder further certifies that the Bidder can meet the specified requirements for insurance, including insurance coverage of the subcontractors, and agrees to name the Oakland Unified School District as Additional Insured for the work specified.

Chef's Depot Inc

Name of Bidder (Person, Firm, or Corporation)



Signature of Bidder's Authorized Representative

Daniel Paredes - Government Sales Rep

Name & Title of Authorized Representative

9/26/25

Date of Signing

Workers' Compensation Insurance Certificate - Attachment "9"

TO BE SUBMITTED WITH PROPOSAL

The Contractor shall execute the following form as required by the California Labor Code, Sections 1860 and 1861:

I am aware of the provisions of Section 3700 of the Labor Code, which require every employer to be insured against liability for workers' compensation or to undertake self insurance in accordance with the provisions of that code, and I will comply with such provisions before commencing the performance of the work of this contract.

Chef's Depot Inc

Name of Bidder (Person, Firm, or Corporation)



Signature of Bidder's Authorized Representative

Daniel Paredes - Government Sales Rep

Name & Title of Authorized Representative

9/26/25

Date of Signing

ATTEST:

By

Signature

Nikki Yeung - Government Sales

Printed Name & Title

Drug-Free Workplace Certification - Attachment "10"

TO BE SUBMITTED WITH PROPOSAL

I, Daniel Paredes, am the Government Sales Rep of
(Print Name) (Title)

(Bidder Name): Chef's Depot Inc I declare, state and certify to all of the following:

1. I am aware of the provisions and requirements of California Government Code §§8350 et seq., the Drug Free Workplace Act of 1990.
2. I am authorized to certify, and do certify, on behalf of Contractor that a drug free workplace will be provided by Contractor by doing all of the following:
 - A. Publishing a statement notifying employees that the unlawful manufacture, distribution, dispensation, possession or use of a controlled substance is prohibited in Contractor's workplace and specifying actions which will be taken against employees for violation of the prohibition;
 - B. Establishing a drug-free awareness program to inform employees about all of the following:
 - i. The dangers of drug abuse in the workplace;
 - ii. Contractor's policy of maintaining a drug-free workplace;
 - iii. The availability of drug counseling, rehabilitation and employee- assistance programs; and
 - iv. The penalties that may be imposed upon employees for drug abuse violations;
 - B. Requiring that each employee engaged in the performance of the Contract be given a copy of the statement required by subdivision (A), above, and that as a condition of employment by Contractor in connection with the Work of the Contract, the employee agrees to abide by the terms of the statement.
 - C. Contractor agrees to fulfill and discharge all of Contractor's obligations under the terms and requirements of California Government Code §8355 by, inter alia, publishing a statement notifying employees concerning: (a) the prohibition of any controlled substance in the workplace, (b) establishing a drug-free awareness program, and (c) requiring that each employee engaged in the performance of the Work of the Contract be given a copy of the statement required by California Government Code §8355(a) and requiring that the employee agree to abide by the terms of that statement.
2. Contractor and I understand that if the District determines that Contractor has either: (a) made a false certification herein, or (b) violated this certification by failing to carry out and to implement the requirements of California Government Code §§8355, the Contract awarded herein is subject to termination, suspension of payments, or both.
3. Contractor and I further understand that, should Contractor violate the terms of the Drug-Free Workplace Act of 1990, Contractor may be subject to debarment in accordance with the provisions of California Government Code §§8350, et seq.
4. Contractor and I acknowledge that Contractor and I are aware of the provisions of California Government Code §§8350, et seq. and hereby certify that Contractor and I will adhere to, fulfill, satisfy and discharge all provisions of and obligations under the Drug-Free Workplace Act of 1990.

I declare under penalty of perjury under the laws of the State of California that all of the foregoing is true and correct.

Executed at Spring Valley, NY this day of 9/26/25
(City and State) (Date)

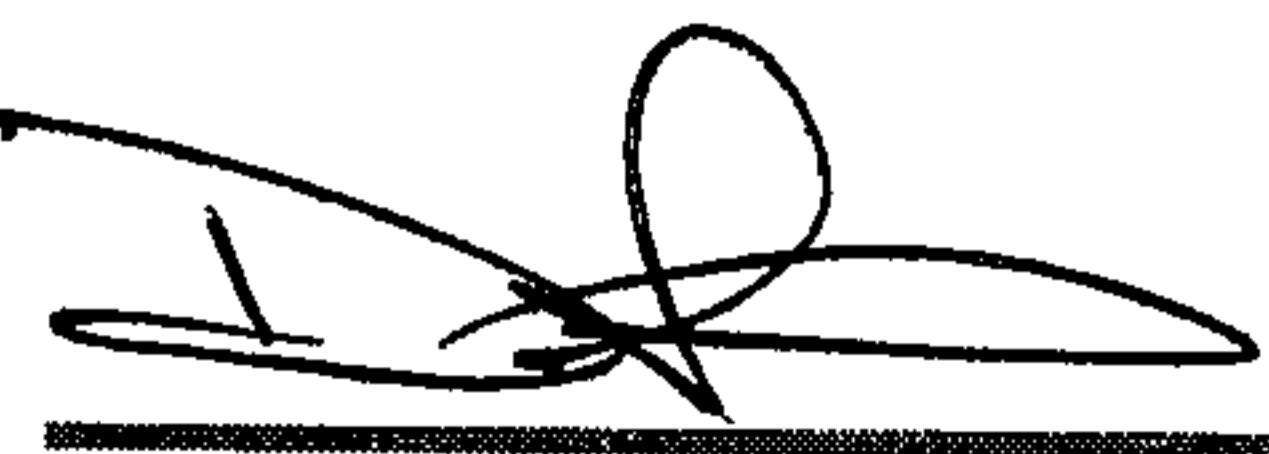
(Signature)

Daniel Paredes
(Name Handwritten or Typed Name)

Equal Opportunity Employment - Attachment "11"

TO BE SUBMITTED WITH PROPOSAL

Federal affirmative action regulations mandate that Federal contractors include an Equal Opportunity (EO) clause in all contracts, subcontracts and purchase orders. The intent is to make the nondiscrimination and affirmative action provisions of Executive Order 11246, Section 503 of the Rehabilitation Act of 1973, the Vietnam Era Veterans' Readjustment Assistance Act, and the Jobs for Veterans act flow down to all tiers of contractors. This contractor and subcontractor shall abide by the requirements of 41 CFR §§ 60-1.4(a), 60-300.5(a) and 60-741.5(a). These regulations prohibit discrimination against qualified individuals based on their status as protected veterans or individuals with disabilities, and prohibit discrimination against all individuals based on their race, color, religion, sex, sexual orientation, gender identity or national origin. Moreover, these regulations require that covered prime contractors and subcontractors take affirmative action to employ and advance in employment individuals without regard to race, color, religion, sex, sexual orientation, gender identity, national origin, disability or veteran status.

CERTIFICATE

I/We hereby certify that the Chef's Depot Inc (Company) is an equal opportunity employer as defined in the Equal Opportunity Act.

DATE: 9/26/25

Chef's Depot Inc

CONTRACTOR

By:  _____

Fingerprinting/Criminal Background Investigation Certification - Attachment "12"

TO BE SUBMITTED WITH PROPOSAL

FINGERPRINTING NOTICE AND ACKNOWLEDGEMENT FOR ALL CONTRACTS EXCEPT WHEN CONSTRUCTION EXCEPTION IS MET (Education Code Section 45125.1)

Other than business entities performing construction, reconstruction, rehabilitation, or repair who have complied with Education Code section 45125.2, business entities entering into contracts with the District must comply with Education Code sections 45125.1. Such entities are responsible for ensuring full compliance with the law and should therefore review all applicable statutes and regulations. The following information is provided simply to assist such entities with compliance with the law:

1. You (as a business entity) shall ensure that each of your employees who interacts with pupils outside of the immediate supervision and control of the pupil's parent or guardian or a school employee has a valid criminal records summary as described in Education Code section 44237. (Education Code §45125.1(a).) You shall do the same for any other employees as directed by the District. (Education Code §45125.1(c).) When you perform the criminal background check, you shall immediately provide any subsequent arrest and conviction information it receives to the District pursuant to the subsequent arrest service. (Education Code §45125.1(a).)
2. You shall not permit an employee to interact with pupils until the Department of Justice has ascertained that the employee has not been convicted of a felony as defined in Education Code section 45122.1. (Education Code §45125.1(e).) See the lists of violent and serious felonies in **Attachment A** to this Notice.
3. Prior to performing any work or services under your contract with the District, and prior to being present on District property or being within the vicinity of District pupils, you shall certify in writing to the District under the penalty of perjury that neither the employer nor any of its employees who are required to submit fingerprints, and who may interact with pupils, have been convicted of a felony as defined in Education Code section 45122.1, and that you are in full compliance with Education Code section 45125.1. (Education Code §45125.1(f).) For this certification, you shall use the form in **Attachment B** to this Notice.
4. If you are providing the above services in an emergency or exceptional situation, you are not required to comply with Education Code section 45125.1, above. An "emergency or exceptional" situation is one in which pupil health or safety is endangered or when repairs are needed to make a facility safe and habitable. The District shall determine whether an emergency or exceptional situation exists. (Education Code §45125.1(b).)
5. If you are an individual operating as a sole proprietor of a business

entity, you are considered an employee of that entity for purposes of Education Code section 45125.1, and the District shall prepare and submit your fingerprints to the Department of Justice as described in Education Code section 45125.1(a). (Education Code §45125.1(h).)

I, as Government Sales Rep *[insert "owner" or officer title]* of Chef's Depot Inc
[insert name of business entity], have read the foregoing and agree that Chef's Depot Inc
[insert name of business entity] will comply with the requirements of Education Code §45125.1 as applicable, including submission of the certificate mentioned above.

Dated: 9/26/25

Name: Daniel Paredes

Signature: 

Title: Government Sales Rep

Page intentionally left blank

ATTACHMENT A

Violent and Serious Felonies

Under Education Code sections 45122.1 and 45125.1, no employee of a contractor or subcontractor who has been convicted of or has criminal proceedings pending for a violent or serious felony may come into contact with any student. A violent felony is any felony listed in subdivision (c) of Section 667.5 of the Penal Code. Those felonies are presently defined as:

- (1) Murder or voluntary manslaughter.
- (2) Mayhem.
- (3) Rape as defined in paragraph (2) or (6) of subdivision (a) of Section 261 or paragraph (1) or (4) of subdivision (a) of Section 262.
- (4) Sodomy as defined in subdivision (c) or (d) of Section 286.
- (5) Oral copulation as defined in subdivision (c) or (d) of Section 288a.
- (6) Lewd or lascivious act as defined in subdivision (a) or (b) of Section 288.
- (7) Any felony punishable by death or imprisonment in the state prison for life.
- (8) Any felony in which the defendant inflicts great bodily injury on any person other than an accomplice which has been charged and proved as provided for in Section 12022.7, 12022.8, or 12022.9 on or after July 1, 1977, or as specified prior to July 1, 1977, in Sections 213, 264, and 461, or any felony in which the defendant uses a firearm which use has been charged and proved as provided in subdivision (a) of Section 12022.3, or Section 12022.5 or 12022.55.
- (9) Any robbery.
- (10) Arson, in violation of subdivision (a) or (b) of Section 451.
- (11) Sexual penetration as defined in subdivision (a) or (j) of Section 289.
- (12) Attempted murder.
- (13) A violation of Section 18745, 18750, or 18755.
- (14) Kidnapping.
- (15) Assault with the intent to commit a specified felony, in violation of Section 220.
- (16) Continuous sexual abuse of a child, in violation of Section 288.5.
- (17) Carjacking, as defined in subdivision (a) of Section 215.
- (18) Rape, spousal rape, or sexual penetration, in concert, in violation of Section 264.1.

(19) Extortion, as defined in Section 518, which would constitute a felony violation of Section 186.22 of the Penal Code.

(20) Threats to victims or witnesses, as defined in Section 136.1, which would constitute a felony violation of Section 186.22 of the Penal Code.

(21) Any burglary of the first degree, as defined in subdivision (a) of Section 460, wherein it is charged and proved that another person, other than an accomplice, was present in the residence during the commission of the burglary.

(22) Any violation of Section 12022.53.

(23) A violation of subdivision (b) or (c) of Section 11418.

A serious felony is any felony listed in subdivision (c) Section 1192.7 of the Penal Code. Those felonies are presently defined as:

(1) Murder or voluntary manslaughter; (2) Mayhem; (3) Rape; (4) Sodomy by force, violence, duress, menace, threat of great bodily injury, or fear of immediate and unlawful bodily injury on the victim or another person; (5) Oral copulation by force, violence, duress, menace, threat of great bodily injury, or fear of immediate and unlawful bodily injury on the victim or another person; (6) Lewd or lascivious act on a child under the age of 14 years; (7) Any felony punishable by death or imprisonment in the state prison for life; (8) Any felony in which the defendant personally inflicts great bodily injury on any person, other than an accomplice, or any felony in which the defendant personally uses a firearm; (9) Attempted murder; (10) Assault with intent to commit rape, or robbery; (11) Assault with a deadly weapon or instrument on a peace officer; (12) Assault by a life prisoner on a non-inmate; (13) Assault with a deadly weapon by an inmate; (14) Arson; (15) Exploding a destructive device or any explosive with intent to injure; (16) Exploding a destructive device or any explosive causing bodily injury, great bodily injury, or mayhem; (17) Exploding a destructive device or any explosive with intent to murder; (18) Any burglary of the first degree; (19) Robbery or bank robbery; (20) Kidnapping; (21) Holding of a hostage by a person confined in a state prison; (22) Attempt to commit a felony punishable by death or imprisonment in the state prison for life; (23) Any felony in which the defendant personally used a dangerous or deadly weapon; (24) Selling, furnishing, administering, giving, or offering to sell, furnish, administer, or give to a minor any heroin, cocaine, phencyclidine (PCP), or any methamphetamine-related drug, as described in paragraph (2) of subdivision (d) of Section 11055 of the Health and Safety Code, or any of the precursors of methamphetamines, as described in subparagraph (A) of paragraph (1) of subdivision (f) of Section 11055 or subdivision (a) of Section 11100 of the Health and Safety Code; (25) Any violation of subdivision (a) of Section 289 where the act is accomplished against the victim's will by force, violence, duress, menace, or fear of immediate and unlawful bodily injury on the victim or another person; (26) Grand theft involving a firearm; (27) carjacking; (28) any felony offense, which would also constitute a felony violation of Section 186.22; (29) assault with the intent to commit mayhem, rape, sodomy, or oral copulation, in violation of Section 220; (30) throwing acid or flammable substances, in violation of Section 244; (31) assault with a deadly weapon, firearm, machine gun, assault weapon, or semiautomatic firearm or assault on a peace officer or firefighter, in violation of Section 245; (32) assault with a deadly weapon against a public transit employee, custodial officer, or school employee, in violation of Sections 245.2, 245.3, or 245.5; (33) discharge of a firearm at an inhabited dwelling, vehicle, or aircraft, in violation of Section 246; (34) commission of rape or sexual penetration in concert with another person, in violation of Section 264.1; (35) continuous sexual abuse of a child, in violation of Section 288.5; (36) shooting from a vehicle, in violation of subdivision (c) or (d) of Section 26100; (37) intimidation of victims or witnesses, in violation of Section 136.1; (38) criminal threats, in violation of Section 422; (39) any attempt to commit a crime listed in this subdivision other than an assault; (40) any violation of Section 12022.53; (41) a violation of subdivision (b) or (c) of Section 11418; and (42) any conspiracy to commit an offense described in this subdivision.

ATTACHMENT B

Form for Certification of Lack of Felony Convictions

Note: This form must be submitted by the owner, or an officer, of the contracting entity before it may commence any work or services, and before it may be present on District property or be within the vicinity of District pupils.

Entity Name: Chef's Depot Inc
Date of Entity's Contract with District: 9/26/25
Scope of Entity's Contract with District: Provide kitchen equipment

I, Daniel Paredes [insert name], am the Government Sales Rep [insert "owner" or officer title] for Chef's Depot Inc [insert name of business entity] ("Entity"), which entered a contract on 9/26, 2025, with the District for kitchen equipment.

I certify that (1) pursuant to Education Code section 45125.1(f), neither the Entity, nor any of its employees who are required to submit fingerprints and who may interact with pupils, have been convicted of a felony as defined in Education Code section 45122.1; and (2) the Entity is in full compliance with Education Code section 45125.1, including but not limited to each employee who will interact with a pupil outside of the immediate supervision and control of the pupil's parent or guardian having a valid criminal background check as described in Education Code section 44237.

I declare under penalty of perjury that the foregoing is true and correct to the best of my knowledge.

Date: 9/26, 2025

Signature: 

Typed Name: Daniel Paredes

Title: Government Sales Rep

Entity: Chef's Depot Inc

Certificate of Independent Price Determination - Attachment "13"

TO BE SUBMITTED WITH PROPOSAL

Both the SFA and Bidder shall execute this Certificate of Independent Price Determination.

Chef's Depot Inc		
Name of Bidder		Name of SFA

1. By submission of this offer, the offeror (Bidder) certifies and, in the case of a joint offer, each party thereto certifies as to its own organization that in connection with this procurement:
 - a. The prices in this offer have been arrived at independently—without consultation, communication, or agreement—for the purpose of restricting competition, as to any matter relating to such prices with any other offeror or with any competitor;
 - b. Unless otherwise required by law, the prices which have been quoted in this offer have not been knowingly disclosed by the offeror and will not knowingly be disclosed by the offeror prior to opening the case of an advertised procurement, directly or indirectly to any other offeror or to any competitor; and
 - c. No attempt has been made or will be made by the offeror to induce any person or firm to submit, or not to submit, an offer for the purpose of restricting competition.
2. Each person signing this offer on behalf of the offeror certifies that:
 - a. He or she is the person in the offeror's organization responsible within the organization for the decision as to the prices being offered herein and has not participated, and will not participate, in any action contrary to (1)(a) through (1)(c) above; or
 - b. He or she is not the person in the offeror's organization responsible within the organization for the decision as to the prices being offered herein, but that he or she has been authorized in writing to act as agent for the persons responsible for such decision in certifying that such persons have not participated, and will not participate, in any action contrary to (1)(a) through (1)(c) above and as their agent does hereby so certify; and he or she has not participated, and will not participate, in any action contrary to (1)(a) through (1)(c) above.

To the best of my knowledge, this vendor and its affiliates, subsidiaries, officers, directors, and employees are not currently under investigation by any governmental agency and have not in the last three years been convicted or found liable for any act prohibited by state or federal law in any jurisdiction, involving conspiracy or collusion with respect to bidding on any public contract, except as follows (provide detail):

		Government Sales Rep		9/26/25
Signature of Bidder's Authorized Representative		Title		Date

In accepting this offer, the SFA certifies that no representative of the SFA has taken any action that may have jeopardized the independence of the offer referred to above.

Signature of SFA's Authorized Representative		Title		Date

Suspension And Debarment Certification - Attachment "14"
TO BE SUBMITTED WITH PROPOSAL

INSTRUCTIONS: SFA to obtain from any potential vendor or existing contractor for all contracts in excess of \$100,000. This form is required each time a Proposal for goods/services over \$100,000 is solicited or when renewing/extending an existing contract exceeding \$100,000 per year (Includes Food Service Management and Food Service Consulting Contracts).

**Certification Regarding Debarment, Suspension, Ineligibility and Voluntary Exclusion
Lower Tier Covered Transactions**

This certification is required by the regulations implementing Executive Order 12549, Debarment and Suspension, 7 CFR Part 3017, Section 3017.510, Participants' responsibilities. The regulations were published as Part IV of the January 30, 1989, Federal Register (pages 4722 – 4733). Copies of the regulations may be obtained by contacting the Department of Agriculture agency with which this transaction originated.

**(BEFORE COMPLETING CERTIFICATION,
READ INSTRUCTIONS ON THE FOLLOWING PAGE)**

1. The prospective lower tier participant certifies, by submission of this proposal, that neither it nor its principals is presently debarred, suspended, proposed for debarment, declared ineligible, or voluntarily excluded from participation in this transaction by any Federal department or agency.
2. Where the prospective lower tier participant is unable to certify to any of the statements in this certification, such prospective participant shall attach an explanation to this proposal.

Name of School Food Authority

Agreement Number

Potential Vendor or Existing Contractor (Lower Tier Participant):

Daniel Paredes

Printed Name



Signature

Government Sales Rep

Title

9/26/25

Date

DO NOT SUBMIT THIS FORM RETAIN WITH THE APPLICABLE CONTRACT OR PROPOSAL RESPONSES.

INSTRUCTIONS FOR CERTIFICATION

1. By signing and submitting this form, the prospective lower tier participant (one whose contract for goods or services exceeds the Federal procurement small purchase threshold fixed at \$100,000) is providing the certification set out on the reverse side in accordance with these instructions.
2. The certification in this clause is a material representation of fact upon which reliance was placed when this transaction was entered into. If it is later determined that the prospective lower tier participant knowingly rendered an erroneous certification, in addition to other remedies available to the Federal Government, the department or agency with which this transaction originated may pursue available remedies, including suspension and/or debarment.
3. The prospective lower tier participant shall provide immediate written notice to the person to which this proposal is submitted if at any time the prospective lower tier participant learns that its certification was erroneous when submitted or has become erroneous by reason of changed circumstances.
4. The terms "covered transaction," "debarred," "suspended," "ineligible," "lower tier covered transaction," "participant," "person," "primary covered transaction," "principal," "proposal," and "voluntarily excluded," as used in this clause, have the meanings set out in the Definitions and Coverage sections of rules implementing Executive Order 12549. You may contact the person to which this proposal is submitted for assistance in obtaining a copy of those regulations.
5. The prospective lower tier participant agrees by submitting this form that, should the proposed covered transaction be entered into, it shall not knowingly enter into any lower tier covered transaction with a person who is debarred, suspended, declared ineligible, or voluntarily excluded from participation in this covered transaction, unless authorized by the department or agency with which this transaction originated.
6. The prospective lower tier participant further agrees by submitting this form that it will include this clause titled "Certification Regarding Debarment, Suspension, Ineligibility and Voluntary Exclusion – Lower Tier Covered Transactions," without modification, in all lower tier covered transactions and in all solicitations for lower tier covered transactions.
7. A participant in a covered transaction may rely upon a certification of a prospective participant in a lower tier covered transaction that it is not debarred, suspended, ineligible, or voluntarily excluded from the covered transaction, unless it knows that the certification is erroneous. A participant may decide the method and frequency by which it determines the eligibility of its principals. Each participant may, but is not required to, check the Nonprocurement List.
8. Nothing contained in the foregoing shall be construed to require establishment of a system of records in order to render in good faith the certification required by this clause. The knowledge and information of a participant is not required to exceed that which is normally possessed by a prudent person in the ordinary course of business dealings.
9. Except for transactions authorized under paragraph 5 of these instructions, if a participant in a covered transaction knowingly enters into a lower tier covered transaction with a person who is suspended, debarred, ineligible, or voluntarily excluded from participation in this transaction, in addition to other remedies available to the Federal Government, the department or agency with which this transaction originated may pursue available remedies, including suspension and/or debarment.

Certification Regarding Lobbying - Attachment "15"

TO BE SUBMITTED WITH PROPOSAL

INSTRUCTIONS: To be completed and submitted **ANNUALLY** by (1) any child nutrition entity receiving Federal reimbursement in excess of \$100,000 per year and (2) potential or existing contractors/Vendors as part of an original Proposal, contract renewal or extension when the contract exceeds \$100,000.

Applicable to Grants, Subgrants, Cooperative Agreements, and Contracts
Exceeding \$100,000 in Federal Funds

Submission of this certification is a prerequisite for making or entering into this transaction and is imposed by section 1352, Title 31, U.S. Code. This certification is a material representation of fact upon which reliance was placed when this transaction was made or entered into. Any person who fails to file the required certification shall be subject to a civil penalty of not less than \$10,000 and not more than \$100,000 for each such failure.

The undersigned certifies, to the best of his or her knowledge and belief, that:

- (1) No Federal appropriated funds have been paid or will be paid by or on behalf of the undersigned, to any person for influencing or attempting to influence an officer or employee of any agency, a Member of Congress, an officer or employee of Congress, or an employee of a Member of Congress in connection with the awarding of a Federal contract, the making of a Federal grant, the making of a Federal loan, the entering into a cooperative agreement, and the extension, continuation, renewal, amendment, or modification of a Federal contract, grant, loan, or cooperative agreement.
- (2) If any funds other than Federal appropriated funds have been paid or will be paid to any person for influencing or attempting to influence an officer or employee of any agency, a Member of Congress, an officer or employee of Congress, or an employee of a Member of Congress in connection with this Federal grant or cooperative agreement, the undersigned shall complete and submit Standard Form-LLL, "Disclosure Form to Report Lobbying," in accordance with its instructions.
- (3) The undersigned shall require that the language of this certification be included in the award documents for all covered subawards exceeding \$100,000 in Federal funds at all appropriate tiers and that all subrecipients shall certify and disclose accordingly.

Name of School Food Authority Receiving Child Nutrition Reimbursement In Excess of \$100,000:	Agreement Number:	
Address of School Food Authority:		
Printed Name and Title of Submitting Official:	Signature	Date:
OR		
Name of Vendor: Chef's Depot Inc		
Printed Name and Title: Daniel Paredes - Government Sales Rep	Signature 	Date: 9/26/25

DISCLOSURE OF LOBBYING ACTIVITIES - N/A

Complete this form to disclose lobbying activities pursuant to 31 U.S.C. 1352 0348-0046

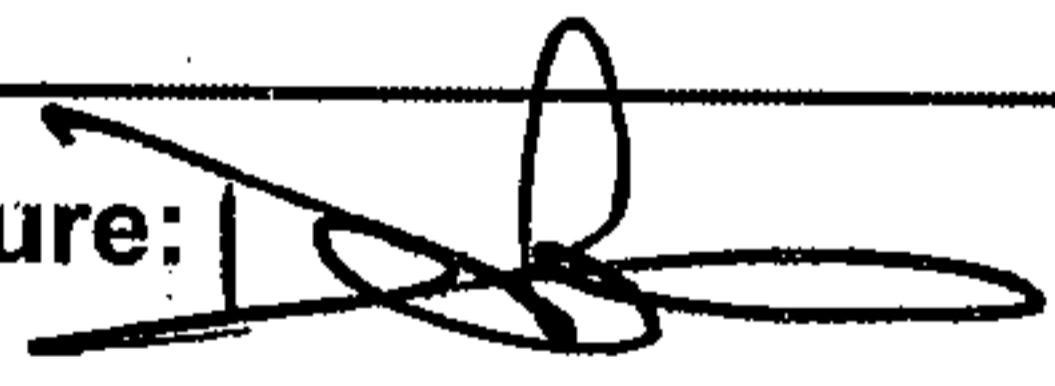
<p>1. Type of Federal Action:</p> <p>a. contract b. grant c. cooperative agreement d. loan e. loan guarantee f. loan insurance</p>	<p>2. Status of Federal Action:</p> <p>a. bid/offer/application b. initial award c. post-award</p>	<p>3. Report Type:</p> <p>a. initial filing b. material change</p> <p>For material change only: Year ____ quarter ____</p> <p>Date of last report _____</p>
<p>4. Name and Address of Reporting Entity:</p> <p>____ Prime ____ Subawardee Tier _____, if Known:</p> <p>Congressional District, if known:</p>		<p>5. If Reporting Entity in No. 4 is Subawardee, Enter Name and Address of Prime:</p> <p>Congressional District, if known:</p>
<p>6. Federal Department/Agency:</p>	<p>7. Federal Program Name/Description:</p> <p>CFDA Number, if applicable: _____</p>	
<p>8. Federal Action Number, if known:</p>	<p>9. Award Amount, if known: \$ _____</p>	
<p>10. a. Name and Address of Lobbying Registrant <i>(if individual, last name, first name, MI):</i></p>	<p>10. b. Individuals Performing Services <i>(including address if different from No. 10a) (last name, first name, MI):</i></p>	
<p>11. Information requested through this form is authorized by title 31 U.S.C. section 1352. This disclosure of lobbying activities is a material representation of fact upon which reliance was placed by the tier above when this transaction was made or entered into. This disclosure is required pursuant to 31 U.S.C. 1352. This information will be reported to the Congress semi-annually and will be available for public inspection. Any person who fails to file the required disclosure shall be subject to a civil penalty of not less than \$10,000 and not more than \$100,000 for each such failure.</p>	<p>Signature: </p> <p>Print Name: Daniel Paredes</p> <p>Title: Government Sales Rep</p> <p>Telephone No.: 845-414-5897</p> <p>Date: 9/26/25</p>	
<p>Federal Use Only</p>		<p>Authorized for Local Reproduction Standard Form - LLL (Rev. 7-97)</p>

INSTRUCTIONS FOR COMPLETION OF SF-LLL, DISCLOSURE OF LOBBYING ACTIVITIES

This disclosure form shall be completed by the reporting entity, whether subawardee or prime Federal recipient, at the initiation or receipt of a covered Federal action, or a material change to a previous filing, pursuant to title 31 U.S.C. section 1352. The filing of a form is required for each payment or agreement to make payment to any lobbying entity for influencing or attempting to influence an officer or employee of any agency, a Member of Congress, an officer or employee of Congress, or an employee of a Member of Congress in connection with a covered Federal action. Complete all items that apply for both the initial filing and material change report. Refer to the implementing guidance published by the Office of Management and Budget for additional information.

1. Identify the type of covered Federal action for which lobbying activity is and/or has been secured to influence the outcome of a covered Federal action.
2. Identify the status of the covered Federal action.
3. Identify the appropriate classification of this report. If this is a followup report caused by a material change to the information previously reported, enter the year and quarter in which the change occurred. Enter the date of the last previously submitted report by this reporting entity for this covered Federal action.
4. Enter the full name, address, city, State and zip code of the reporting entity. Include Congressional District, if known. Check the appropriate classification of the reporting entity that designates if it is, or expects to be, a prime or subaward recipient. Identify the tier of the subawardee, e.g., the first subawardee of the prime is the 1st tier. Subawards include but are not limited to subcontracts, subgrants and contract awards under grants.
5. If the organization filing the report in item 4 checks "Subawardee," then enter the full name, address, city, State and zip code of the prime Federal recipient. Include Congressional District, if known.
6. Enter the name of the federal agency making the award or loan commitment. Include at least one organizational level below agency name, if known. For example, Department of Transportation, United States Coast Guard.
7. Enter the Federal program name or description for the covered Federal action (item 1). If known, enter the full Catalog of Federal Domestic Assistance (CFDA) number for grants, cooperative agreements, loans, and loan commitments.
8. Enter the most appropriate Federal identifying number available for the Federal action identified in item 1 (e.g., Request for Proposal (RFP) number; Invitations for Bid (IFB) number; grant announcement number; the contract, grant, or loan award number; the application/proposal control number assigned by the Federal agency). Included prefixes, e.g., "RFP-DE-90-001."
9. The certifying official shall sign and date the form, print his/her name, title, and telephone number.
10. For a covered Federal action where there has been an award or loan commitment by the Federal agency, enter the Federal amount of the award/loan commitment for the prime entity identified in item 4 or 5.
11.
 - a. Enter the full name, address, city, State and zip code of the lobbying registrant under the Lobbying Disclosure Act of 1995 engaged by the reporting entity identified in item 4 to influence the covered Federal action.
 - b. Enter the full names of the individual(s) performing services, and include full address if different from 10(a). Enter Last Name, First Name, and Middle Initial (MI).

According to the Paperwork Reduction Act, as amended, no persons are required to respond to a collection of information unless it displays a valid OMB control Number. The valid OMB control number for this information collection is OMB No. 0348-0046. Public reporting burden for this collection of information is estimated to average 10 minutes per response, including time for reviewing instructions, searching existing data sources, gathering and maintaining the data needed, and completing and reviewing the collection of information. Send comments regarding the burden estimate or any other aspect of this collection of information, including suggestions for reducing this burden, to the Office of Management and Budget, Paperwork Reduction Project (0348-0046), Washington, DC 20503

**Iran Contracting Act Of 2010 Compliance Affidavit - Attachment
"16"**

TO BE SUBMITTED WITH PROPOSAL

The California Legislature adopted the Iran Contracting Act of 2010 to respond to policies of Iran in a uniform fashion (PCC § 2201(q)). The Iran Contracting Act prohibits Bidders engaged in investment activities in Iran from bidding on, submitting proposals for, or entering into or renewing contracts with public entities for goods and services of one million dollars (\$1,000,000) or more (PCC § 2203(a)). A Bidder who "engages in investment activities in Iran" is defined as either:

1. A Bidder providing goods or services of twenty million dollars (\$20,000,000) or more in the energy sector of Iran, including provision of oil or liquefied natural gas tankers, or products used to construct or maintain pipelines used to transport oil or liquefied natural gas, for the energy sector of Iran; or
2. A Bidder that is a financial institution (as that term is defined in 50 U.S.C. § 1701) that extends twenty million dollars (\$20,000,000) or more in credit to another person, for 45 days or more, if that person will use the credit to provide goods or services in the energy sector in Iran and is identified on a list created by the California Department of General Services (DGS) pursuant to PCC § 2203(b) as a person engaging in the investment activities in Iran.

The Bidder shall certify that at the time of submitting a Proposal for new contract or renewal of an existing contract, the Bidder is not identified on the DGS list of ineligible businesses or persons and that the Bidder is not engaged in investment activities in Iran in violation of the Iran Contracting Act of 2010.

California law establishes penalties for providing false certifications, including civil penalties equal to the greater of \$250,000 or twice the amount of the contract for which the false certification was made; contract termination; and three-year ineligibility to bid on contracts (PCC § 2205).

To comply with the Iran Contracting Act of 2010, the Bidder shall provide its vendor or financial institution name, and City Business Tax Registration Certificate (BTRC) if available, in completing **ONE** of the options shown below.

OPTION #1: CERTIFICATION

I, the official named below, certify that I am duly authorized to execute this certification on behalf of the Bidder or financial institution identified below, and that the Bidder or financial institution identified below is not on the current DGS list of persons engaged in investment activities in Iran and is not a financial institution extending twenty million dollars (\$20,000,000) or more in credit to another person or vendor, for 45 days or more, if that other person or vendor will use the credit to provide goods or services in the energy sector in Iran and is identified on the current DSG list of persons engaged in investment activities in Iran.

Vendor Name/Financial Institution (printed) Chef's Depot Inc	BTRC (or n/a) N/A
By (Authorized Signature) 	
Print Name and Title of Person Signing Daniel Paredes - Government Sales Rep	
Date Executed 9/26/25	City Approval (Signature) (Print Name)

OPTION #2: EXEMPTION

Pursuant to PCC § 2203(c) and (d), a public entity may permit a Bidder or financial institution engaged in investment activities in Iran, on a case-by-case basis, to be eligible for, or to bid on, submit a proposal for, or enter into, or renew, a contract for goods and services. If the Bidder or financial institution identified below has obtained an exemption from the certification requirement under the Iran Contracting Act of 2010, the Bidder or financial institution shall complete and sign below and attach documentation demonstrating the exemption approval.

Vendor Name/Financial Institution (printed)	BTRC (or n/a)	
By (Authorized Signature)		
Print Name and Title of Person Signing		
Date Executed	City Approval (Signature)	(Print Name)

Clean Air And Water Certification - Attachment "17"

TO BE SUBMITTED WITH PROPOSAL

Applicable if the contract exceeds \$100,000 or the Contracting Officer has determined that the orders under an indefinite quantity contract in any one year will exceed \$100,000 or a facility to be used has been the subject of a conviction under the Clean Air Act (41 U.S.C. 1857c-8(c)(1) or the Federal Water Pollution Control Act 33 1319(d) and is listed by EPA or the contract is not otherwise exempt.

Chef's Depot Inc

Name of Vendor Company

THE VENDOR AGREES AS FOLLOWS:

- A. To comply with all the requirements of Section 114 of the Clean Air Act, as amended (41 U.S.C. 1857, et seq., as amended by Public Law 91-604) and Section 308 of the Federal Water Pollution Control Act (33 U.S.C. 1251, et seq., as amended by Public Law 92-500), respectively, relating to inspection, monitoring, entry, reports and information as well as other requirements specified in Section 114 and Section 308 of the Air Act and the Water Act, respectively, and all regulations and guidelines issued there under before the award of this contract.
- B. That no portion of the work required by this prime contract will be performed in a facility listed on the Environmental Protection Agency List of Violating Facilities on the date when this contract was awarded unless and until the EPA eliminates the name of such facility or facilities from such listing.
- C. To use his/her best efforts to comply with clean air standards and clean water standards at the facilities in which the contract is being performed.
- D. To insert the substance of the provisions of this clause in any nonexempt subcontract, including this paragraph.

THE TERMS IN THIS CLAUSE HAVE THE FOLLOWING MEANINGS:

- A. The term "Air Act" means the Clean Air Act, as amended (41 U.S.C. 1957 et seq., as amended by Public Law 91-604).
- B. The term "Water Act" means Federal Water Pollution Control Act, as amended (33 U.S.C. 1251 et seq., as amended by Public Law 92-500).
- C. The term "Clean Air Standards" means any enforceable rules, regulations, guidelines, standards, limitations, orders, controls, prohibitions, or other requirements which are contained in, issued under, or otherwise adopted pursuant to the Air Act or Executive Order 11738, an applicable implementation plan as described in section 110(d) of the Clean Air Act (42 U.S.C. 1957c-5(d)), an approved implementation procedure or plan under Section 111(c) or Section 111(d), respectively, of the Air Act (42 U.S.C. 1857c-6(c) or (d)), or approved implementation procedure under Section 112(d) of the Air Act (42 U.S.C. 1857c-7(d)).
- D. The term "Clean Air Standards" means any enforceable limitation, control, condition, prohibition, standard, or other requirement which is promulgated pursuant to the Water Act or contained in a permit issued to a discharger by the Environmental Protection Agency or by a State under an approved program, as authorized by Section 402 of the Water Act (33 U.S.C. 1342) or by local government to ensure compliance with pretreatment regulations as required by Section 307 of the Water Act (33 U.S.C. 1317).
- E. The term "Compliance" means compliance with clean air or water standards. Compliance shall also mean compliance with a schedule or plan ordered or approved by a court of competent jurisdiction, the Environmental Protection Agency or an Air or Water Pollution Control Agency in accordance with the requirements of the Air Act or Water Act and regulations issued pursuant thereto.
- F. The term "facility" means any building, plant, installation, structure, mine, vessel, or other floating craft, location or sites of operations, owned, leased or supervised by the Food Service Management Company.

Daniel Paredes

Authorized Representative

Government Sales Rep

Title

9/26/25

Date



OAKLAND UNIFIED SCHOOL DISTRICT

Community Schools, Thriving Students

Request for Proposal (RFP) #26-162NS

**SERVICE LINE EQUIPMENT
K-12 MEAL PROGRAM
FOR NUTRITION SERVICES**

**OAKLAND UNIFIED SCHOOL DISTRICT
Attention: Procurement Department
900 High Street, 2nd Floor
OAKLAND, CA 94601**

**email: procurement@ousd.org
phone: (510) 879-2990**

**Proposals Due:
September 30, 2025 at 2:00 PM PST**

THE TERMS AND CONDITIONS OF THIS RFP ARE GOVERNED BY
THE APPLICABLE STATE AND FEDERAL LAWS.

Table of Contents

Table of Contents	2
RFP Schedule Of Events	3
Notice to Bidders	4
General Information about the District	4
Introduction	4
Proposal Instructions and General Requirements	5
Pricing	6
District Evaluation/Selection Process	6
Protests Selection Procedure	7
Terms and Conditions	8
Delivery Requirements and Locations	15
Proposal Submission Instructions	17
Proposal Submission Checklist - Attachment "1"	18
Itemized Bid List-Attachment "2"	19
Request For Proposal Signature Page - Attachment "3"	24
The Evaluation Criteria-Attachment "4"	25
Vendor Questionnaire - Attachment "5"	27
References - Attachment "6"	29
Non Collusion Affidavit - Attachment "7"	31
Bidder's Statement Regarding Insurance Coverage - Attachment "8"	32
Workers' Compensation Insurance Certificate - Attachment "9"	33
Drug-Free Workplace Certification - Attachment "10"	34
Equal Opportunity Employment - Attachment "11"	35
Fingerprinting/Criminal Background Investigation Certification - Attachment "12"	36
Certificate of Independent Price Determination - Attachment "13"	42
Suspension And Debarment Certification - Attachment "14"	43
Certification Regarding Lobbying - Attachment "15"	45
Iran Contracting Act Of 2010 Compliance Affidavit - Attachment "16"	48
Clean Air And Water Certification - Attachment "17"	50

RFP Schedule Of Events

The following schedule will be used by the District for this RFP.

DATE	ACTION
RFP Posting/First Advertisement:	August 29, 2025
Deadline for Questions:	September 18, 2025 @ 4:00 p.m. PST
Proposal/Bid Submitted to District:	September 30, 2025 @ 2:00 p.m. PST
Potential Interviews (If Necessary):	October 6-9, 2025
Final Bid Award Notice:	October 16, 2025
Contract Start Date:	November, 2025

OUSD will use every effort to adhere to the schedule. However, OUSD reserves the right to amend the schedule, as it deems necessary.

The District reserves the right to amend or cancel this proposal at any time. Proposers are responsible for viewing any new changes related to this proposal online at <https://www.ousd.org/bidopportunities>.

If a proposer desires any clarification or questions of any kind regarding this solicitation, the proposer must make a written request and should be addressed via email to:

Procurement Department
[*procurement@ousd.org*](mailto:procurement@ousd.org)

NOTE: Contacting Board members and/or any District staff other than the procurement analyst who is outlined above, may disqualify the proposer from the selection process.

Notice to Bidders

The Oakland Unified School District (“District”) is requesting submission of statements of qualifications and proposals (“Proposals”) from qualified persons, firms, partnerships corporations, associations or professional organizations (“Bidder(s)”) for the provision and delivery of Food Service Supplies (“Products”) to the District, as further described herein.

General Information about the District

The Oakland Unified School District (OUSD) is the eleventh largest school district in California. OUSD located in and is approximately coterminous with the City of Oakland, California, and is located on the east side of the San Francisco Bay, approximately 10 miles from San Francisco.

The Oakland Unified School District (District) operates under a locally-elected seven member Board form of government and provides educational services to grades CDC/Pre-K - Adult. The District operates twenty-eight (28) child development centers, forty-five (45) elementary schools, eleven (11) middle schools, nine (9) high schools, four (4) K-8, three (3) 6-12, six (6) alternative ed and other programs as well. The District serves approximately 34,700 students. We encourage you to visit our website (<http://www.ousd.org>) for more information about our District.

Introduction

The District has one (1) delivery site. The District is seeking Proposals from qualified companies to procure and deliver products. This RFP defines the Program (as defined below), the products and the services that are being sought from the Bidders and generally outlines the Program requirements.

Oakland Unified School District (“District”) is seeking bids for purchase and delivery of Kitchen Equipment in quantities to be ordered during the term of the contract. Additionally, the District is seeking installation for service line equipment specified in the Purchase Specifications list.

This bid is for purchase by, and delivery to, the Oakland Unified School District (also referred to hereinafter in this document as the “District”) of the items described in this bid package (“Items”) during the term of the contract in quantities to be determined and ordered as needed by the District, all in accordance with the District’s bid package documents for this contract, including but not limited to the Invitation for Bids, Purchase Specifications, Bid Form, Agreement Form, and Instructions to Bidders.

Proposal Instructions and General Requirements

Bidder Questions Regarding this Request for Proposals – Any questions regarding this Request for Proposals shall be **emailed** to the Oakland Unified Procurement Department at procurement@ousd.org prior to **September 18, 2025 at 2:00 pm PST** deadline.

Deadline for Receipt of RFPs – Proposals must be submitted via **email** to the District no later than the date and time specified in the RFP. Late submissions will not be considered. Proposals must be complete and signed; unsigned proposals will be rejected. Once the submission deadline has passed, all proposals will be reviewed and evaluated based on pricing, specifications, and other relevant criteria. No award decisions will be made at the time of opening.

The RFP – All numbers on the bid should be stated in figures, and signatures of all individuals must be in long-hand. Unsigned Proposals will not be accepted. FAX copies of Proposals will not be accepted for formal advertised RFPs.

Responsibility – Bidders are solely responsible for ensuring their Proposal is received by the District in accordance with the solicitation requirements before the date and time specified in the RFP, and at the place specified. The District shall not be responsible for any delays in mail or by common carriers or by transmission errors or delays or mistaken delivery.

Drug Free Workplace Certificate – In accordance with California Government Code §§8350 et seq., the Drug Free Workplace Act of 1990, the Successful Bidder will be required to execute a Drug Free Workplace Certificate concurrently with execution of the Agreement. The Successful Bidder will be required to implement and take the affirmative measures outlined in the Drug Free Workplace Certificate and in California Government Code §§8350 et seq. Failure of the Successful Bidder to comply with the measures outlined in the Drug Free Workplace Certificate and in California Government Code §§8350 et seq. may result in penalties, including without limitation, the termination of the Agreement, the suspension of any payment of the Contract Price otherwise due under the Contract Documents and/or debarment of the Successful Bidder.

Term of Contract – Minimum contract term is one (1) year. Quoted prices must stay in effect for twelve (12) months after award of RFP and may be extended upon mutual consent of Oakland Unified School District and vendor for two (2) additional one (1) year periods in accordance with provisions contained in the Education Code, Sections 17596. If extended, price increases may be negotiated **subject to existing local market conditions, and as determined by the California Consumer Price Index (CPI) with prior District consent.** In the event of a general price decrease the District reserves the right to revoke the RFP award unless the decrease is passed on to the District.

Pricing

Provide a detailed Statement of Pricing for Products to be provided. Bidder shall provide evidence and documentation of cost (at invoice price) to the District upon the District's request. Errors in price computations will not excuse Bidder from holding price.

Pricing Terms – Contract prices awarded for fixed price items shall remain firm for the contract period. Prices proposed for all items will be for the period July 1, 2025, through June 30, 2026. All orders placed by the District will be delivered and invoiced at the Agreement price regardless of the actual delivery date. Proposers must agree to fix contract fees for the first year. If the organization intends to revise its fee schedule after the initial one-year period, it must give written notice to the District 90 days in advance of any fee change. Fees may be changed only on the contract expiration date with 90 days notice. These fees are subject to negotiation and approval by the District.

Itemized Bid List – The District's Itemized Bid Lists is attached hereto.

Modifications of Contracted Price Lists to Acquire Additional Goods or Increase Quantities of Listed Goods – Items not included in the executed contract can be added only if all of the following conditions are met: The total value of all added goods and quantities of listed goods does not exceed the limit specified in the original solicitation and contract. If the value of additional goods exceeds the specified limit, a separate procurement for those goods must be conducted or these purchases will be considered an unallowable cost. The USDA recommends limiting the additional costs to 10 percent of the estimated value of the contract.

All Other Costs or Fees – Pricing information for, without limitation, transactional services, additional services, Bidder's mark-up on subconsultant and subcontractor prices, general conditions, and all other categories of costs, expenses, fees, or charges that Bidder anticipates will be a part of its price to provide the Products.

District Evaluation/Selection Process

Basis for Selection – The responsiveness, competency and responsibility of Bidders and of their proposed subcontractors will be considered in making the award of contract. Any Bidder before being awarded a contract may be required to furnish evidence to the District that the Bidder has sufficient means and experience in the type of work called for to assure completion of the contract in a satisfactory manner. The District reserves the right to reject the Proposal of any Bidders as not responsible and not qualified to provide the products under consideration who have previously failed to perform properly or to complete on time contracts with the District of a nature similar to this procurement. A responsive Proposal is one that meets all terms, conditions, and specifications of the Proposal. The award of this solicitation is conditional on the winning bidder accepting the terms of the contract available to view online at <https://www.ousd.org/procurement/bid-opportunities/current-bid-opportunities>.

A Proposal which substantially conforms, though not strictly responsive, to a call for Proposals may be accepted if the variance cannot have affected the amount of the Proposal or given a Bidder an advantage or benefit not allowed to other Bidders. or, in other words, if the variance is inconsequential.

The District reserves the right to reject any and all Proposals or alternatives and waive any informality or irregularity in the Proposals or in the bidding, and to determine responsiveness and responsibility of Bidder, including but not limited to those areas mentioned above. The District makes no representation that participation in the RFP process will lead to an award of contract or any consideration whatsoever.

Evaluation/Award – The District intends to select one of the Bidders—but reserves the right to select no Bidder or more than one Bidder—that best meet(s) the District’s needs to provide the Products as described in this RFP. From the Bidders that provide Proposals to the District, the District may, at its discretion, interview some or all of those Bidders. One or more Bidders may be selected (“Successful Bidder”). The Successful Bidder will be selected based on qualifications and demonstrated competence that include relevant experience with public agencies, including local agencies, and a proven track record of success for these types of Products. Proposals will be evaluated separately and will be awarded to one or more Bidders based on the highest scored Proposal. The Evaluation Criteria, Descriptions, and Point Scoring are listed in Attachment 4. The contract awarded through this bid will be non-exclusive, meaning that the District may purchase, at its discretion, food service supplies from other vendors throughout the contract if it deems necessary.

Previous Performance – Bidders are advised that the District reserves the right to reject a Proposal from a Bidder that cannot demonstrate the ability to provide the goods or services required. Bidders who have demonstrated unsatisfactory performance may be subject to disqualification as a responsible Bidder submitting a Proposal, thereby disqualifying the Bidder from contract award.

Protests Selection Procedure

Any Bidder may protest the Districts issuance of a notice of “Not To Award” if it believes that the District has incorrectly selected another proposer for the award. Notice of protest shall be filed with the District within five (5) business days after the notice of “Not to Award” is received. The notice of protest must include the name of the protesting bidder, a detailed description of specific grounds for protest, and copies of all supporting documents. Provider should submit the protest electronically by email to:

Rosaura M. Altamirano
Senior Manager, Supply Chain & Logistics
rosaura.altamirano@ousd.org

The protest must contain a complete statement of any and all bases for the protest.

The protest must refer to the specific portions of any documents that form the bases for the protest.

The party filing the protest must concurrently transmit a copy of the protest and any attached documentation to all other parties with a direct financial interest that may be adversely affected by the outcome of the protest, and all other Bidders who appear to have a reasonable prospect of receiving an award depending upon the outcome of the protest.

The procedure and time limits set forth in this paragraph are mandatory and are each Bidder's sole and exclusive remedy in the event of protest. Failure to comply with any of these procedures, at the District's sole discretion, shall constitute a waiver of any right to further pursue the protest, including filing a Government Code Claim or legal proceedings.

Terms and Conditions

In addition to the following, this RFP is subject to the terms of the Contract attached and included herewith.

Acceptance of Proposals – The District reserves the right to reject any or all Proposals and to select individual items. Proposals may be rejected on grounds of non-responsiveness or non-responsibility. The District does **NOT** guarantee that all items shown on this Proposal will be purchased. The right is reserved to purchase additional quantities at the Proposal prices during the contract period. It is not intended that large variations from the listed quantities will be made, but quantity additions or deletions shall be at the option of the District. The District reserves the right to reject any or all Proposals or waive any irregularities or informalities in any Proposals or in the bidding.

Alteration of Request for Proposal Text – Changes in or additions to the Request for Proposal, as well as any attachments, amendments or other official correspondence related to this Request for Proposal may not be manually, electronically or otherwise altered by Bidder or Bidder's agent(s). Recapitulations of the Products proposed upon, alternative Proposals, or any other modification of the Request for Proposal which is not specifically called for in the award agreement documents may result in the District's rejection of the Proposal as not being responsive to the Request for Proposal. No oral or telephonic modification of any Proposal submitted will be considered and a telegraphic modification may be considered only if the postmark evidences that a confirmation of the telegram duly signed by the Bidder was placed in the mail prior to the opening of Proposals.

Anti-discrimination – Bidder shall certify that it is an Equal Opportunity Employer and has made a good faith effort to improve employment of people from historically disadvantaged groups and agrees to meet Federal and State guidelines. No discrimination shall be made in the employment of persons upon public works in this project because of the sex, race, color, national origin or ancestry, religion, or handicap of such personnel.

Authorized Distributor – Successful Bidder must be an Authorized Distributor for the product offered, or with Bidder's quote, Bidder must submit documentation from an Authorized Distributor from whom Bidder has purchased the specified materials.

Proposal Negotiations – A Proposal response to any specific item of this Request for Proposal with terms such as "negotiable," "will negotiate," or similar, will be considered non-responsive to that specific item.

California Public Records Act – Responses to this RFP will become the property of the District and subject to the California Public Records Act, Government Code sections 7920.000 et seq. Those elements in each response that are trade secrets as that term is defined in Civil Code section 3426.1(d) or otherwise exempt by law from disclosure and which are prominently marked as "TRADE SECRET," "CONFIDENTIAL," or "PROPRIETARY" may not be subject to disclosure. The District shall not be liable or responsible for the disclosure of any such records including, without limitation, those so marked if disclosure is deemed to be required by law or by an order of the Court. A Bidder that indiscriminately identifies all or most of its response as exempt from disclosure without justification may be deemed non-responsive. In the event the District is required to defend an action on a Public Records Act request for any of the contents of a response marked "Confidential," "Proprietary," or "Trade Secret," the Bidder agrees, by submission of its response for the District's consideration, to defend, hold harmless, and indemnify the District from all costs and expenses, including attorneys' fees, in any action or liability arising under the Public Records Act.

Cancellation of Solicitation – The District may cancel this solicitation at any time.

Clarification, Corrections or Changes to Specifications – All clarifications, corrections, or changes to the solicitation documents will be made by Addendum only. Bidders shall not rely upon interpretations, corrections, or changes made in any other manner, whether by telephone, in person, or in email. Interpretations, corrections, and changes shall not be binding unless made by the Addendum. All Addenda issued shall become part of the Agreement documents. Addenda will be sent to all known solicitation holders by email or U.S. mail. It is the Bidder's sole responsibility to ascertain that it has received all Addenda issued for this solicitation. All Addenda must be acknowledged and returned on or before the Submittal Deadline, unless otherwise directed by an Addendum.

Competency of Bidders Submitting a Proposal – A proposal will only be accepted from, or contract awarded to, a contractor who is licensed in accordance with the law, to

whom a proposal form has been issued by the District and who has successfully performed on projects of similar character and scope to the proposed work. A representative of the District, prior to contract award may examine the business premises of any Bidder submitting a Proposal. Bidders submitting a Proposal shall agree to fully comply with all City, State and Federal laws, regulations and ordinances governing performance of an awarded contract. It will be the responsibility of the contractor to obtain any clearances necessary for completion of the contract.

Compliance with OSHA – Bidder agrees that all item(s) offered comply with all applicable Federal and the State Occupational Safety and Health Act, laws, standards and regulations, and that Bidder will indemnify and hold the District harmless for any failure to so conform.

Cost of Proposal Preparation – Cost of preparation of the response to this RFP is solely the responsibility of the Bidder submitting a Proposal. The District accepts or implies no liability in the cost of preparation.

Definitions – Responsible: a bidding party possessing the skill, judgment, qualifications, integrity and financial ability necessary to timely perform and complete the contract being bid. Responsive: a Proposal which meets all of the specifications set forth in the RFP.

District Requirements – The quantity shown is the estimate of consumption for the contract period. The needs of the District may be substantially more or less than such referenced quantities. The articles, supplies or services listed in the RFP and required during the contract period shall be ordered and purchased from the Successful Bidder(s) during such period. The District shall have the right to issue purchase orders up to and including the last day of the contract period even though the time provided for delivery may extend beyond such period.

Errors and Corrections – The Proposal submitted must not contain any erasures, interlineations, or other corrections unless each such correction creates no inconsistency and is suitably authenticated by signatures/initials of the person or persons signing the Proposal. Correction of any such errors shall be made prior to the Proposal opening only. In the event of inconsistency between words and figures in the Proposal price, words shall control figures. In the event that the District determines that any Proposal is unintelligible, inconsistent or ambiguous, the District may reject such Proposal as not being responsive. The Proposal cannot be corrected after the Proposal opening.

Examination of Proposal Documents – Bidders submitting a Proposal shall thoroughly examine and be familiar with the specifications. The failure or omission of any Bidder submitting a Proposal to receive or examine any Proposal document(s), forms, instruments, Addendum or other document there existing shall in no way relieve any Bidder submitting a Proposal from obligations with respect to this RFP or to the

contract. The submission of a Proposal shall be taken as prima facie evidence of compliance with this section.

Examination of Locations – It shall be the responsibility of the Successful Bidder to establish knowledge of the District and the specific delivery locations to familiarize him/herself with the access and egress, construction or building difficulties and method of delivery, all of which could affect the Successful Bidders ability to service the District. It shall be the responsibility of the Successful Bidder to cope with all these eventualities.

Failure to Comply with Instructions – Failure to comply with any of the instructions stated in the Proposal documents may result in rejection of the Proposal.

Any party submitting a Proposal shall not contact, or lobby any District Board member, official, employee, agent or representative during the Bidding process including up to the date of Board action, except as specified in the Proposal for contact. Any party attempting to influence the Proposal including the submittal, review process and awarding of the Proposal will have their Proposal rejected for violating this term and condition of the RFP.

Any party, individual, group or firm, not submitting a Proposal, but which may have a financial or business interest in the award of the Proposal shall not contact or lobby any District Board member, official, employee, agent, contractor or representative, including up to the date of Board action. Any and all public comment regarding the Board's action in the award of this Proposal will be accepted on the date of Board action in a public meeting pursuant to the Brown Act.

FOB Destination Pricing – All shipments shall be made FOB destination, Oakland, California FOB destination indicates that the seller is responsible for shipment until it is tendered to the District. The District will not pay for shipping and handling, nor shall the District pay for any fuel surcharges that are not indicated herein. If the material is not received within the time specified for delivery, it will be received at the discretion of the District. Should it be necessary to refuse delivery of any material contained in the Proposal document, the Bidder shall be responsible for the cost of retrieving the merchandise in question.

Formation of Contract – Bidder's signed Proposal and District's written acceptance with approval from the District's Governing Board shall constitute a binding contract.

Contract Term - It is the intent to award the contract for an initial one (1) year period with the option to renew it for two (2), one-year periods for a possible total contract term of 3 years. The decision to renew the contract(s) will be at the sole discretion of the District and agreed upon by both parties.

Insurance Requirements – Successful Bidder shall maintain insurance as specified in the Section titled, "Minimum Insurance/Coverage." Successful Bidder must furnish the District with the Certificates of Insurance proving coverage as specified in the section titled, "Minimum Insurance/Coverage" and naming the District Additional Insured by

endorsement within ten (10) calendar days. Failure to furnish the required certificates within the time allowed may result in withdrawal of award.

Packing, Crating, Cartage – The cost of all special packing, boxing, crating, or cartage shall be included in the pricing specified on the response unless otherwise specifically stated in the District’s request. Damaged cases or packages may be rejected and returned for credit or immediate replacement, at no cost to the District for product or freight. All costs for containers shall be borne by the vendor.

Recovered Materials – In compliance with edition 6002 of the Solid Waste Disposal Act the District shall procure only items designated in the guidelines of the Environmental Protection Agency (EPA) at 40 CFR part 247 that contain the highest percentage of recovered materials practicable, consistent with maintaining a satisfactory level of competition, where the purchase price of the item exceeds \$10,000 or the value of the quantity acquired during the preceding fiscal year exceeded \$10,000.

40 CFR part 247 defines Recovered Material as waste materials and byproducts which have been recovered or diverted from solid waste, but such term does not include those materials and byproducts generated from, and commonly reused within an original manufacturing process.

Contracting With Minority Owned Businesses – Per CFR 200.321 the District will provide consideration for contracting with a bidder that is a minority or women owned business. CFR 4.62 defines a minority or women owned business as “...at least 51 percent unconditionally-owned by one or more members of a minority group or by one or more women...”

Contracting With Small Businesses – Per CFR 200.321 the District will provide consideration for contracting with a bidder that falls under the definition of small business provided in the Health and Safety Code 23395.20: “ “Small business” means an independently owned and operated business, that is not dominant in its field of operation, that, together with affiliates, has 100 or fewer employees, and that has average annual gross receipts of ten million dollars (\$10,000,000) or less over the past three years.”

Payment – (a) Bidder shall state payment terms offered. (b) Payment will be made on the pay period after receipt and acceptance of goods and/or services and upon department confirmation of such acceptance.

Post Award Meeting – Prior to performing any work or providing any services specified on this Contract, the Successful Bidder may be required to meet with the District’s Nutrition Services Department for the purpose of reviewing the products and services offered herein, determining milestones regarding the District’s expectations, and to discuss any issues related to the execution of this RFP. The Successful Bidder shall perform all work in accordance with such schedule pursuant to the Terms & Conditions

of this RFP and the awarded Contract. The District will approve all materials associated with this RFP.

Right to Inspect Successful Bidder Facilities – The District reserves the right to inspect the Successful Bidder’s facilities prior to award of contract and/or during the term of the contract and if representatives of the District determine after such inspection that the Successful Bidder is not capable of performance satisfactory to the District, the Proposal will not be considered or the Agreement can be canceled.

Substitutions – All Bidders must conform to the specifications set forth in these Proposal documents. The District reserves the right to reject all Proposals that do not conform to the specifications. Do not use “as specified” in responding to this requirement. At a minimum, descriptive technical literature fully describing the claimed “as equal” product must be attached to the Proposal. Suitability and valuation of “equal” rests in the sole discretion of the District.

Taxes – No Proposal shall include Federal Excise Tax, as the District is exempt from such tax and will furnish appropriate tax exemption certificates. The Successful Bidder shall pay all taxes, levies, duties and assessments of every nature due in connection with any work under the contract, shall make any and all payroll deductions required by law, and shall indemnify and hold harmless the District from any liability on account of any and all such taxes, levies, duties, assessments and deductions.

Terms of the Offer – The District’s acceptance of Bidder’s offer shall be limited to the terms herein unless expressly agreed in writing by the District.

Tobacco-Free Environment – All District sites have been designated as tobacco-free environments. Smoking and the use of tobacco products is prohibited at all times on all areas of District property. District property includes school buildings, school grounds, school owned vehicles and vehicles owned by others while on District property.

Withdrawal of Proposal – Any claim by a Bidder of error in its Proposal must be made in compliance with section 5100 et seq. of the Public Contract Code. The Bidders may withdraw Proposals only by written request received by the District’s Nutrition Services Department Interim Executive Director (or Executive Director if instated).

Customer Service – The District requires that the successful Bidder have a dedicated account manager working with The District on a consistent basis.

Minimum Insurance/Coverage: The Bidder agrees to purchase and maintain through the duration of the contract insurance or liability coverage (such as liability coverage provided by a Joint Powers Agency) ensuring their ability to meet their respective defense and indemnity obligations set forth above. Such insurance or liability coverage shall have a limit of liability of no less than \$1,000,000 per claim/occurrence, and \$2,000,000 in the aggregate. For the acts and activities contemplated by this agreement, at a minimum, the following shall be provided:

1. **Commercial General Liability Insurance:** Bidder shall maintain at its expense a policy of commercial general liability insurance, endorsed to include professional liability coverage relative to the scope of service performed by Bidder. Such insurance shall be maintained in a company or companies lawfully authorized to do business in California as admitted carriers so designated by the California Department of Insurance. It is preferred that such carriers will have a financial rating of at least "A,11" status as rated in the most recent edition of Best's Insurance Reports or as amended agreement between the District and Bidder. All policies shall contain a provision requiring thirty (30) days written notice to be given to the District prior to cancellation, modification, or reduction of limits.
2. **Additional Insured Endorsement:** Oakland Unified School District, its elected and appointed officers, agents, employees, volunteers, Bidders and representatives shall be listed as Additional Insured as respects the operations of the named insured. Coverage shall not be limited to the vicarious liability or supervisory role of any additional insured. Said insurance policy shall be endorsed (copy of Endorsement attached to Certificate of Insurance) to include the following language, "Oakland Unified School District, its elected and appointed officers, agents, employees, volunteers, Bidders and representatives shall be listed as Additional Insured as respects the operations of the named insured performed under the terms of this Agreement."
3. **Primary Insurance Endorsement:** In addition to the "Additional Insured" as stated above, said insurance policy shall be endorsed (copy of Endorsement attached to Certificate of Insurance) to include the following language, "Such insurance as is afforded by the Endorsement for the Additional Insured's shall apply as primary insurance. Any other insurance maintained by the District, its elected and appointed officers, agents, employees, Bidders and representatives shall be excess only and not contributing with the insurance afforded by this Endorsement."
4. **Certificate of Insurance:** Prior to commencing services pursuant to this Agreement, Bidder shall provide certificates as evidence of the existence of the insurance required by this Agreement, on insurance certificates executed by a duly-authorized agent of Bidder's insurance provider. Such certificates shall include the Endorsements described in this Agreement as attachments.
5. **Workers' Compensation:** Bidder shall provide Workers' Compensation coverage as required by California law, and in signing this Agreement, makes the following certification: "Bidder is aware of the provisions of Section 3700 of the Labor Code which require every employer to be insured against liability for Workers' Compensation or to undertake self-insurance in accordance with such provisions before commencing the performance of this Agreement." Prior to commencing services pursuant to this Agreement, Bidder shall provide a certificate indicating the existence of Workers' Compensation coverage as required by this

Agreement, on an insurance certificate executed by a duly-authorized agent of Bidder's insurance provider.

6. **Injury and Illness Prevention:** Bidder shall maintain and enforce an Injury and Illness Prevention Program as required by State law, and in signing this Agreement, makes the following certification: "Bidder is aware of the provisions of California Labor Code, Division 5, and of the California Code of Regulations, Title 8, and shall maintain an active Injury and Illness Prevention Plan in accordance with such provisions before commencing the performance of this Agreement." The Injury and Illness Prevention Plan shall be available to the District upon request
7. **Commercial Automobile Liability:** If Bidder is going to operate a vehicle on District property or transport students in any capacity. Limits of liability shall include a minimum of \$1,000,000 combined single limit.
8. **Survivability:** The parties' indemnity and coverage obligations shall survive the termination of this agreement with respect to any claim arising from the parties' actual or alleged performance or non-performance of their respective rights, privileges, or obligations existing under this agreement.
9. **Joint Interests:** In the event of a claim covered by these provisions, the Parties agree to take all steps reasonable or necessary to cooperate in defending and protecting their joint interests, including efforts to reduce defense costs (through joint representation whenever possible), expenses and potential liability exposures.

Delivery Requirements and Locations

Delivery Specifications -

1. The Successful Bidder will partner with the District over the term of the contract resulting from this RFP to procure and deliver Food Service Supplies to the District. The District reserves the rights to make additions to, or deletions from, the lists of school sites to be served at any time during the period of the contract, and revise delivery times as required. Awarded vendor(s) will be required to make direct deliveries to one (1) site. The site requires 1-2 days per week deliveries due to storage limitations or volume purchases and seeks a Bidder that can provide next day delivery for orders submitted before 2pm the previous day.
2. All deliveries shall occur between the hours of 5:00 a.m. and 10:00 a.m. pacific time. Overnight deliveries, or "Dark drops," will not be accepted. If a scheduled delivery day is a holiday, deliveries will occur on the next business day after the holiday.
3. Delivery to site must be completed within the designated delivery timeframe as indicated below. Delivery shall not be made so close to service time as to create concern by the school site.

4. District reserves the right to designate an alternate delivery location if the designated site is unable to receive deliveries for any reason. The District reserves the right to add or remove delivery sites as needed. The District also reserves the right to revise delivery times as required. Additional product and service requirements are outlined within the RFP.

OUSD Delivery Location		
Location	Address	Delivery Times
Warehouse Distribution Center	900 High Street Oakland, CA 94601	5:00 am - 10:00 am

Proposal Submission Instructions

Proposals shall be **emailed** to the Procurement Department at procurement@ousd.org no later than **September 30, 2025 at 2:00pm PST**.

Proposal shall be submitted with subject line:
“Response to RFP Proposal #25-162NS Service Line Equipment”

***When submitting your proposal, be sure to get a ticket number or confirmation email.** Proposals submitted via email should be submitted as PDF file format. PDF file size should be sufficient enough to send via email, the District does not assume responsibility if the PDF file is too large to email. If electronic submission is a factor, the District encourages hand delivery of the proposal directly to the **Procurement Department, 900 High Street 2nd Floor Oakland, CA 94601 between the hours of 9:00am - 2:00pm PST**. All proposals emailed or delivered after scheduled closing time for receipt of proposals will not be considered. Incomplete proposals may be deemed non-responsive and therefore not considered.

The District reserves the right to reject any or all proposals. Proposals and any other information submitted by respondents in response to this RFP shall become the property of the District. Notwithstanding any indication by Contractor of confidential contents, and with the exception of bona fide confidential information, contents of proposals are public documents subject to disclosure under the California Public Records Act after award. The District will not provide compensation to Contractors for any expenses incurred by the Contractors for proposal preparation or for any demonstration that may be made. Contractors submit proposals at their own risk and expense.

Local and Small Local Business Program

In order to provide economic opportunity for Oakland residents and businesses and stimulate economic development in Oakland, the District has implemented a Local, Small Local and Small Local Resident Business Enterprise Program (“Local Business Program”). The District encourages Local, Small and Small Local Resident Businesses to apply.

Contractors claiming preference as a **certified** Oakland Small Business must attach a copy of their certification letter to their bid. This RFP, and subsequent amendments and/or updates will be available at: <https://www.ousd.org/procurement>. **Contractors are responsible for checking this website for information and changes to this RFP.**

Proposal Submission Checklist - Attachment "1"

TO BE SUBMITTED WITH PROPOSAL

Bidder Name:

This checklist must be submitted with Bidder's Proposal.

REQUIRED DOCUMENTS:

- Proposal Submission Checklist (Att. 1, this form)
- Itemized Bid List (Att. 2)
- Request for Proposal Signature Page (Att. 3)
- The Evaluation Criteria (Att. 4)
- Vendor Questionnaire (Att. 5)
- References (Att. 6)
- Non Collusion Affidavit (Att. 7)
- Bidder's Statement Regarding Insurance Coverage (Att. 8)
- Workers' Compensation Insurance Certificate (Att. 9)
- Drug-Free Workplace Certification (Att. 10)
- Equal Opportunity Employment (Att. 11)
- Fingerprinting/Criminal Background Investigation Certification (Att. 12)
- Certificate of Independent Price Determination (Att. 13)
- Suspension and Debarment Certification (Att. 14)
- Certificate Regarding Lobbying (Att. 15)
- Iran Contracting Act of 2010 Compliance Affidavit (Att. 16)
- Statement of Pricing (Include in your proposal)
- Clean Air and Water Certification (Att. 17)
- Addenda

Itemized Bid List-Attachment “2”

Please complete the itemized list below. If you are proposing equivalent items, describe them in the “Equivalent Item Proposed” column. All proposed items must be of equal or higher quality and compatibility with the items specified by the District.

Drawings provided following item list.

LINE ITEMS	EQUIVALENT ITEMS PROPOSED	ESTIMATED QUANTITIES	UNIT BID PRICES	ESTIMATED TOTAL BID PRICES
Food Warming Equipment Co. Inc. Model No. 30B-R-31 (OR EQUIVALENT): <u>Refrigerated Serving Wells</u> . VOLTS: 120 Volts. CONTROL PANEL: Electronic Controller CASTERS: 6x3.5” Casters CUSTOMER SIDE: 12” Drop Down Tray Slide Shelf OPERATOR SIDE: 8” Drop Down SS Cutting Board MISC OPTIONS: Removable Decorative Panels, Exterior Cabinet Upgrade 18GA, Cold Plate (2) - Roll Bonded, Height to be 31”.		15		
Food Warming Equipment Co. Inc. Model No. 30B-31 Series (OR EQUIVALENT) Heated Speed Line VOLTS: 120 Volts		15		

<p>CONTROL PANEL: Mechanical Thermostat WATTS: TBD CUSTOMER SIDE: 12" Drop-Down Tray Slide Shelf OPERATOR SIDE: 8" Drop Down SS Cutting Board MISC OPTIONS: Removable Decorative Panels, Height to Be 31" WARRANTY: 2 Year Parts, 1 Year Labor</p>				
<p>Food Warming Equipment Co. Inc. Model No. CRS-31-31 Series (OR EQUIVALENT) Cash Register Stand MISC OPTIONS: 1.75" Diameter Hole For Cable, Height To Be 31", Depth to Be 38.5", Removable Decorative Panels Standard Packaging</p>		15		

MODEL#: CRS-31-31;

SERIES: CASH REGISTER STAND;

- ① BOTTOM BUMPER: NO BUMPER;
- ② CASTERS: 5" EZ ROLL HEAVY DUTY POLY;
- ③ MISC OPTIONS: 1.75" DIA HOLE FOR CABLE, HEIGHT TO BE 31", DEPTH TO BE 38.5";
- ④ REMOVABLE DECORATIVE PANELS;

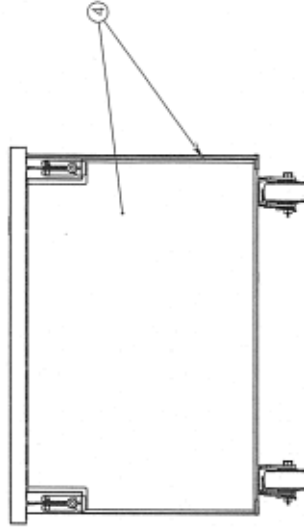
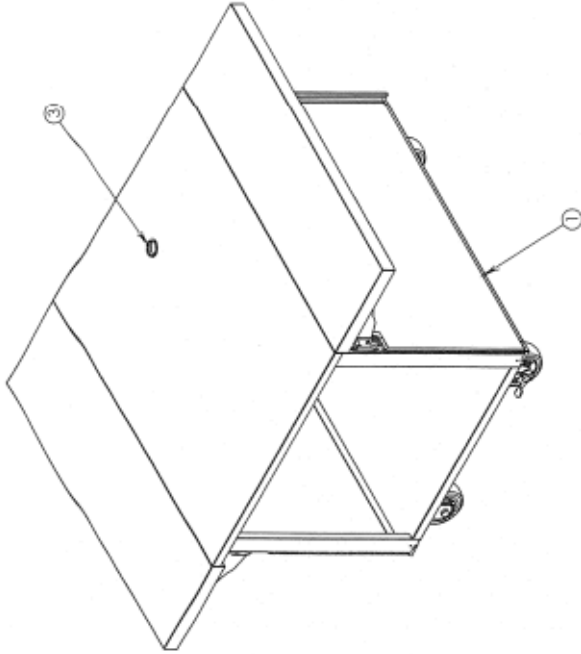
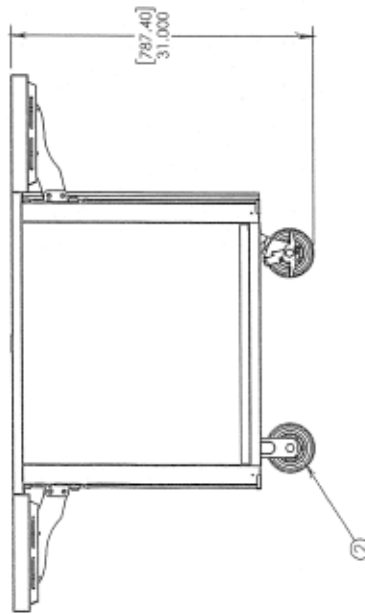
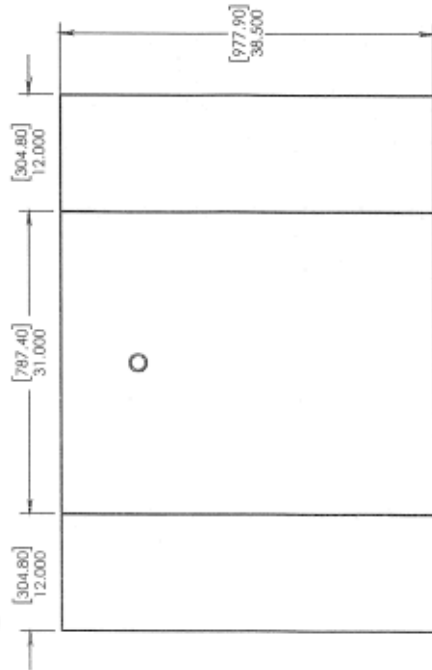

FIVE	
599 Highway 31 West Canton, MS 39014 Tel: (601) 325-7774 Fax: (601) 325-0481	
DRAWING #: CRS-31-31	
DESCRIPTION: CASH REGISTER STAND	
LAST SAVED BY: mfwachin	

DUAL DIMENSIONS ARE O.D. UNLESS OTHERWISE SPECIFIED
 TOLERANCES: DIMENSIONS SHOWN IN: +/- .015 +/- .1 DEG. [mm], inch
 DO NOT SCALE DRAWING

REV: LAST REV DATE: Tuesday, February 25, 2025 7:55:50 AM APPROVAL:

REV: FRC00000415102081: REV: DESCRIPTION

REV DATE: Friday, February 21, 2025 7:45:11 AM

DRAWN BY: SCUK

LAST SAVED BY: SCUK

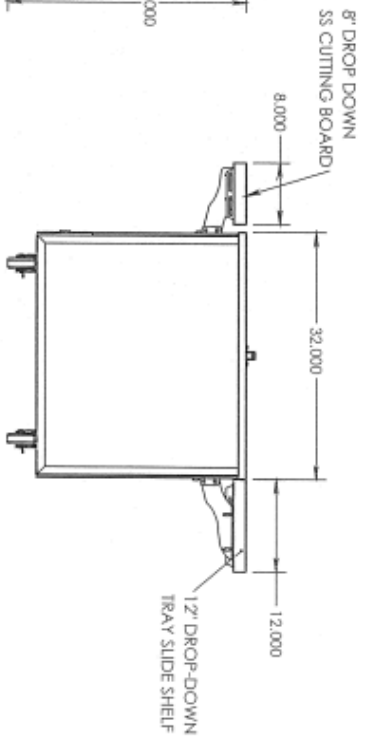
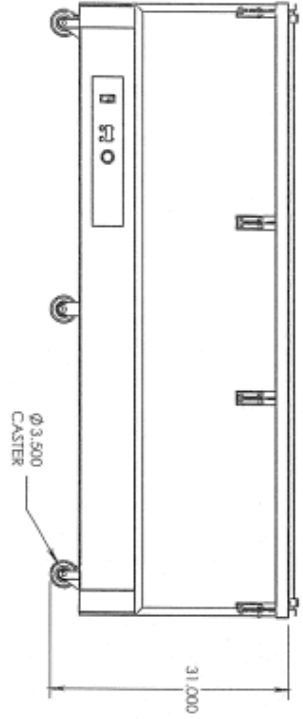
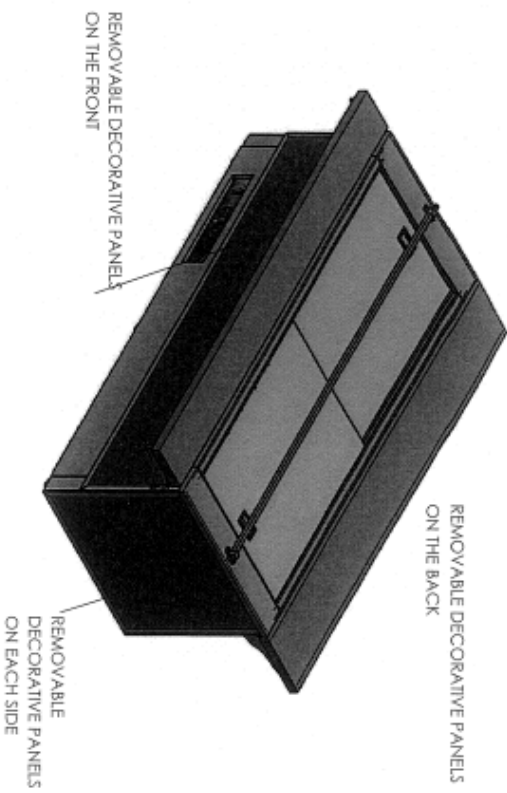
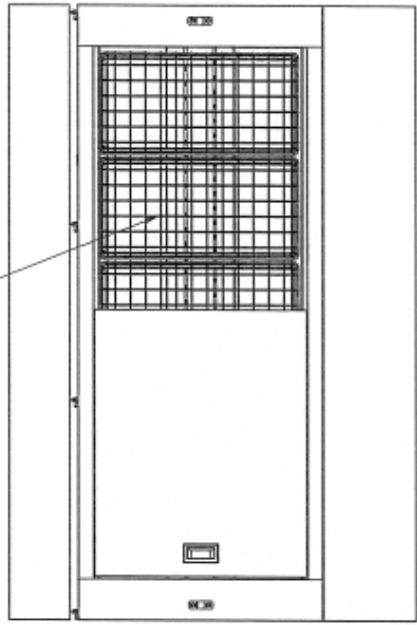

FUE

2009 Highway 31 West
CORNING IN 27181
TEL: (615) 252-2726
FAX: (615) 252-2840

DIMENSIONS ARE O.D.
UNLESS OTHERWISE SPECIFIED

TOLERANCES:
+/- .031 +/- .1 DEG.

DO NOT SCALE DRAWING

DESCRIPTION: HOLDING CART WITH WELL

DRAWING #: HLC-1326-308-31

MODEL #: H1C-1326-308-R-31:
 SERIES: REFRIGERATED SERVING WELLS:
 VOLTS: 120 VOLTS:
 ① CONTROL PANEL: ELECTRONIC CONTROLLER:
 ② CASTERS: 3.5" CASTERS:
 ③ CUSTOMER SIDE: 1/2" DROP-DOWN TRAY SLIDE SHELF:
 ④ OPERATOR SIDE: 8" DROP-DOWN SS CUTTING BOARD:
 MISC. OPTIONS: ⑤ REMOVABLE DECORATIVE PANELS,
 EXTERIOR CABINET UPGRADE 18 GA.

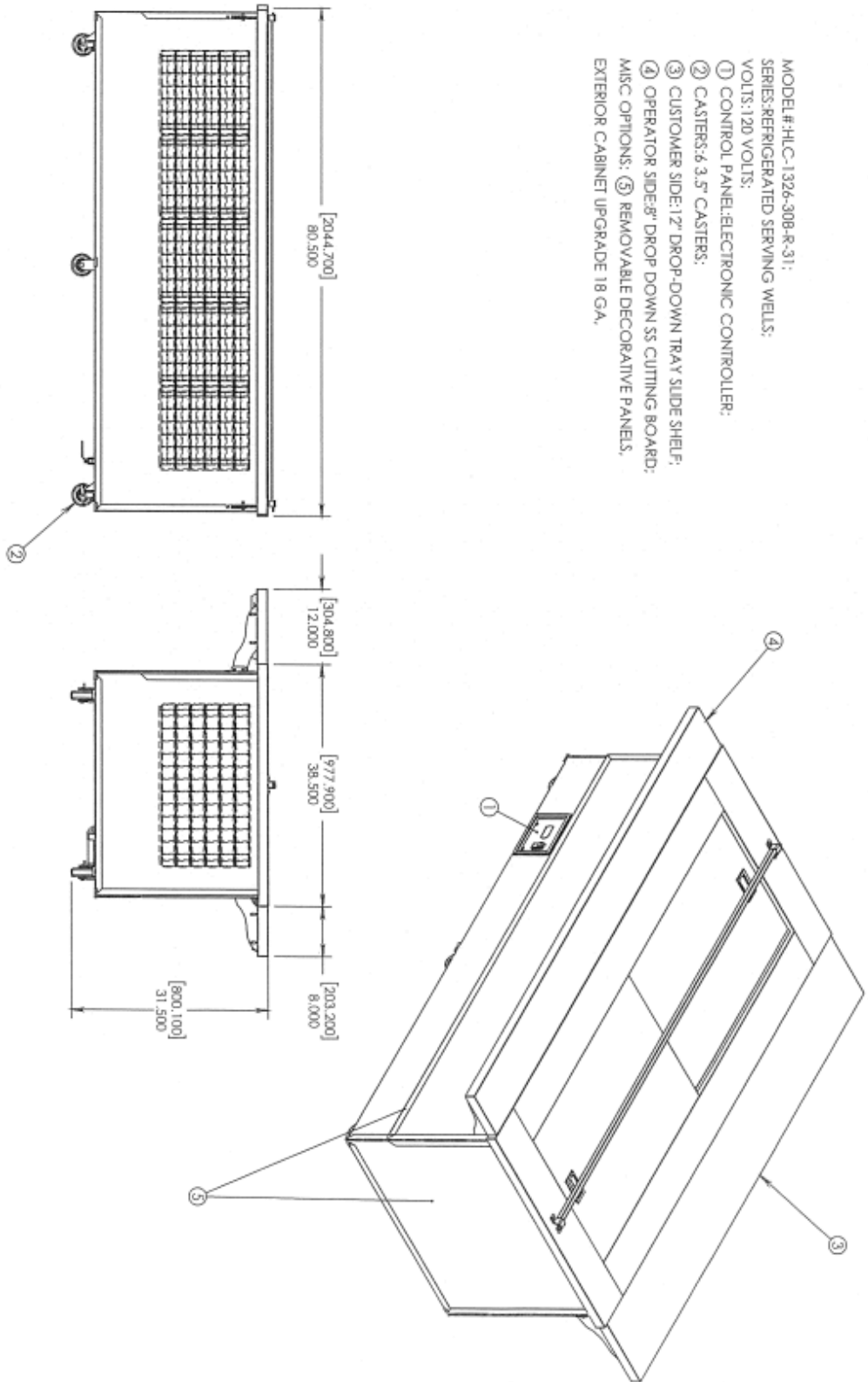

REV: LAST REV DATE: Friday, February 21, 2025 1:53:57 PM APPROVAL: LAST SAVED BY: nmkscshn

	5097 Highway 31 West Portland, IN 47148	DUAL DIMENSIONS ARE O.D. UNLESS OTHERWISE SPECIFIED
	TEL: (315) 525-2774 FAX: (315) 528-0480	DIMENSIONS SHOWN IN: +/- .015 +/- .1 DEG. (mm), inch DO NOT SCALE DRAWING

DRAWING #: H1C-1326-308-R-31
 DESCRIPTION: HOLDING CART WITH WELL

Request For Proposal Signature Page - Attachment "3"
TO BE SUBMITTED WITH PROPOSAL

By signing this, I certify that I am an authorized representative of the Bidder (or individual) and that information contained in this proposal is accurate, true, and binding upon the Bidder.	
Company Name	
Signature of Company Official	
Name of Signer	
Title of Signer	
Email Address	
Complete Mailing Address	
City, State, Zip	
Phone Number	
Date	
Minimum Dollar Amount for Delivery	\$
<input type="checkbox"/>	Check if no minimum dollar amount for delivery is required.
Minimum Case Amount for Delivery	
<input type="checkbox"/>	Check if no minimum case amount for delivery is required.

**The Evaluation Criteria-Attachment “4”
TO BE SUBMITTED WITH PROPOSAL**

Award Criteria	Description and. Points Awarded	Points Based On	Max Points
Price	100% of Max Points: Lowest-priced bid. 80% of Max Points: Second lowest-priced bid. 60% of Max Points: Third lowest-priced bid.	Itemized Bid Lists	25
Delivery Location	100% of Max Points: Ability to the Districts warehouse. 0 Points: Unable to the Districts warehouse.	- Reference forms - Responses to Questionnaire	15
Delivery Time Frame	100% of Max Points: Shortest Delivery Time 80% of Max Points: Second shortest Delivery Time 50% of Max Points: Third shortest Delivery Time 0 Points: 4th shortest or longer Delivery Time.	Responses to Questionnaire	15
Recovered Materials	100% of Max Points: The products quoted contain the highest percentage of recovered materials practicable (defined by 40 CFT part 247), consistent with maintaining a satisfactory level of competition. 0 Points: The products quoted do not contain the highest percentage of recovered materials practicable (defined by 40 CFT part 247), consistent with maintaining a satisfactory level of competition.	Response to Questionnaire	10
Service Reliability and Past Performance	100% of Max Points: Proven ability to provide excellent service as demonstrated by references & vendor questionnaire that show: -Prompt responses and satisfactory resolution to requests for information and complaints & issues -Courtesy and responsiveness to all district personnel at all times -Ready access to decision-making executives and assigned point of contact. 0 Points: References and/or vendor questionnaire that demonstrate poor performance or inability to meet criteria described above.	-Reference forms -Responses to Questionnaire	10

Contracting with Small Businesses	100% of Max Points: Qualifies as a small business. 0 Points: Does not qualify as a small business	Responses to Questionnaire	5
Contracting with Minority- Owned Businesses	100% of Max Points: Majority business ownership by individuals who identify as women or BIPOC (Black, Indigenous and People of Color). 0 Points: Majority business ownership not by individuals who identify as women or BIPOC.	Responses to Questionnaire	5
		TOTAL	85

By signing this, I acknowledge that I have reviewed OUSD’s Evaluation Criteria.

Name of Bidder (Person, Firm, or Corporation): _____

Signature of Bidder’s Authorized Representative: _____

Date of Signing: _____

Vendor Questionnaire - Attachment "5"
TO BE SUBMITTED WITH PROPOSAL

Please complete this qualifying criteria questionnaire, use a separate sheet if necessary, and submit with your proposal.

1. Delivery - Are you able to deliver all items on the Item List to the Distribution Warehouse at 900 High Street Oakland, CA 94601? ___ Yes ___ No
2. Lead Time - What is the lead time for the items on the Item List from time of PO to delivery to the Distribution Warehouse?
3. Recovered Materials - Do the products quoted contain the highest percentage of recovered materials practicable (defined by 40 CFT part 247), consistent with maintaining a satisfactory level of competition?
4. Service Reliability and Past Performance - Will you be able to provide point/s of contact with whom the District can communicate through e-mail and by phone?
5. Service Reliability and Past Performance - How many years has your company been in the Service Line Products business?
6. Service Reliability and Past Performance - Has your firm resigned or been replaced at the will of a district(s) during the school year within the last 36 months? If so, explain.
7. Service Reliability and Past Performance - During the previous school year how many K-12 schools districts did you service?
8. Service Reliability and Past Performance - What is your procedure for notifying customers of a product recall?
9. Contracting with Small Businesses - Does your business meet the criteria of a small business as defined in CA Health and Safety Code Section 23395.20 : "Small business" means an independently owned and operated business, that is not dominant in its field of operation, that, together with affiliates, has 100 or fewer employees, and that has average annual gross receipts of ten million dollars (\$10,000,000) or less over the past three years..."?
 - Yes
 - No
10. Contracting with Minority-Owned Businesses - per CFR 200.321: Does the majority (51% or more) of your business ownership identify as minority individual(s)?
 - Yes
 - No

In accordance with the contract documents, the undersigned propose to supply all of the product and perform all work specified in the contract documents in accordance with the proposal.

Name of Bidder (Person, Firm, or Corporation): _____

Signature of Bidder's Authorized Representative: _____

Date of Signing: _____

Print Name & Title of Authorized Representative: _____

Phone Number: _____

Email: _____

References - Attachment "6"
TO BE SUBMITTED WITH PROPOSAL

Please submit three (3) current school district References requiring multiple deliveries per week. An unresponsive reference will **not** be considered a valid Reference. The Bidder is expected to exercise due diligence to ensure the References listed will be responsive to communications from the District.

Reference #1

School District	
Contact Person & Title	
Telephone Number	
Required Number of Deliveries per Week	

Reference #2

School District	
Contact Person & Title	
Telephone Number	
Required Number of Deliveries per Week	

Reference #3

School District	
Contact Person & Title	
Telephone Number	

Required Number of Deliveries per Week	
---	--

Non Collusion Affidavit - Attachment "7"
PUBLIC CONTRACTS CODE SECTION 7106
TO BE SUBMITTED WITH PROPOSAL

State of California
County of _____

Bidder's Name _____, being first duly sworn, deposes and says that he or she is Owner of Contractor Name _____ the party making the foregoing Proposal that the Proposal is not made in the interest of, or on behalf of, any undisclosed person, partnership, company, association, organization, or corporation; that the Proposal is genuine and not collusive or sham; that the Bidder has not directly or indirectly induced or solicited any other Bidder to put in a false or sham Proposal, and has not directly or indirectly colluded, conspired, connived, or agreed with any Bidder or anyone else to put in a sham Proposal, or that anyone shall refrain from bidding; that the Bidder has not in any manner, directly or indirectly, sought by agreement, communication, or conference with anyone to fix the Proposal price of the Bidder or any other Bidder, or to fix any overhead, profit, or cost element of the Proposal price, or of that of any other Bidder, or to secure any advantage against the public body awarding the contract of anyone interested in the proposed contract; that all statements contained in the Proposal are true; and further, that the Bidder has not, directly or indirectly, submitted his or her Proposal price or any breakdown thereof, or the contents thereof, or divulged information or data relative thereto, or paid, and will not pay, any fee to any corporation, partnership, company association, organization, Proposal depository, or to any member or agent thereof to effectuate a collusive or sham Proposal."

(Date)

Signed at (Place)

Bidder Name
(Person, Firm, Corp.)

Authorized Representative

Address

Representative's Name

City, State, Zip

Representative's Title

Bidder's Statement Regarding Insurance Coverage - Attachment "8"

TO BE SUBMITTED WITH PROPOSAL

Bidder HEREBY CERTIFIES that the Bidder has reviewed and understands the insurance coverage requirements specified in the Request for Proposals. Should the Bidder be awarded the contract for the work, Bidder further certifies that the Bidder can meet the specified requirements for insurance, including insurance coverage of the subcontractors, and agrees to name the Oakland Unified School District as Additional Insured for the work specified.

Name of Bidder (Person, Firm, or Corporation)

Signature of Bidder's Authorized Representative

Name & Title of Authorized Representative

Date of Signing

Workers' Compensation Insurance Certificate - Attachment "9"

TO BE SUBMITTED WITH PROPOSAL

The Contractor shall execute the following form as required by the California Labor Code, Sections 1860 and 1861:

I am aware of the provisions of Section 3700 of the Labor Code, which require every employer to be insured against liability for workers' compensation or to undertake self insurance in accordance with the provisions of that code, and I will comply with such provisions before commencing the performance of the work of this contract.

Name of Bidder (Person, Firm, or Corporation)

Signature of Bidder's Authorized Representative

Name & Title of Authorized Representative

Date of Signing

ATTEST:

By _____
Signature

Printed Name & Title

Drug-Free Workplace Certification - Attachment "10"

TO BE SUBMITTED WITH PROPOSAL

I, _____, am the _____ of
(Print Name) (Title)

(Bidder Name): _____ I declare, state and certify to all of the following:

1. I am aware of the provisions and requirements of California Government Code §§8350 et seq., the Drug Free Workplace Act of 1990.
2. I am authorized to certify, and do certify, on behalf of Contractor that a drug free workplace will be provided by Contractor by doing all of the following:
 - A. Publishing a statement notifying employees that the unlawful manufacture, distribution, dispensation, possession or use of a controlled substance is prohibited in Contractor's workplace and specifying actions which will be taken against employees for violation of the prohibition;
 - B. Establishing a drug-free awareness program to inform employees about all of the following:
 - i. The dangers of drug abuse in the workplace;
 - ii. Contractor's policy of maintaining a drug-free workplace;
 - iii. The availability of drug counseling, rehabilitation and employee- assistance programs; and
 - iv. The penalties that may be imposed upon employees for drug abuse violations;
 - B. Requiring that each employee engaged in the performance of the Contract be given a copy of the statement required by subdivision (A), above, and that as a condition of employment by Contractor in connection with the Work of the Contract, the employee agrees to abide by the terms of the statement.
 - C. Contractor agrees to fulfill and discharge all of Contractor's obligations under the terms and requirements of California Government Code §8355 by, inter alia, publishing a statement notifying employees concerning: (a) the prohibition of any controlled substance in the workplace, (b) establishing a drug-free awareness program, and (c) requiring that each employee engaged in the performance of the Work of the Contract be given a copy of the statement required by California Government Code §8355(a) and requiring that the employee agree to abide by the terms of that statement.
2. Contractor and I understand that if the District determines that Contractor has either: (a) made a false certification herein, or (b) violated this certification by failing to carry out and to implement the requirements of California Government Code §§8355, the Contract awarded herein is subject to termination, suspension of payments, or both.
3. Contractor and I further understand that, should Contractor violate the terms of the Drug-Free Workplace Act of 1990, Contractor may be subject to debarment in accordance with the provisions of California Government Code §§8350, et seq.
4. Contractor and I acknowledge that Contractor and I are aware of the provisions of California Government Code §§8350, et seq. and hereby certify that Contractor and I will adhere to, fulfill, satisfy and discharge all provisions of and obligations under the Drug-Free Workplace Act of 1990.

I declare under penalty of perjury under the laws of the State of California that all of the foregoing is true and correct.

Executed at _____ this day of _____
(City and State) (Date)

(Signature)

(Name Handwritten or Typed Name)

Equal Opportunity Employment - Attachment "11"

TO BE SUBMITTED WITH PROPOSAL

Federal affirmative action regulations mandate that Federal contractors include an Equal Opportunity (EO) clause in all contracts, subcontracts and purchase orders. The intent is to make the nondiscrimination and affirmative action provisions of Executive Order 11246, Section 503 of the Rehabilitation Act of 1973, the Vietnam Era Veterans' Readjustment Assistance Act, and the Jobs for Veterans act flow down to all tiers of contractors. This contractor and subcontractor shall abide by the requirements of 41 CFR §§ 60-1.4(a), 60-300.5(a) and 60-741.5(a). These regulations prohibit discrimination against qualified individuals based on their status as protected veterans or individuals with disabilities, and prohibit discrimination against all individuals based on their race, color, religion, sex, sexual orientation, gender identity or national origin. Moreover, these regulations require that covered prime contractors and subcontractors take affirmative action to employ and advance in employment individuals without regard to race, color, religion, sex, sexual orientation, gender identity, national origin, disability or veteran status.

CERTIFICATE

I/We hereby certify that the _____ (Company) is an equal opportunity employer as defined in the Equal Opportunity Act.

DATE: _____

CONTRACTOR

By: _____

Fingerprinting/Criminal Background Investigation Certification - Attachment "12"

TO BE SUBMITTED WITH PROPOSAL

FINGERPRINTING NOTICE AND ACKNOWLEDGEMENT **FOR ALL CONTRACTS EXCEPT WHEN CONSTRUCTION EXCEPTION IS MET** (Education Code Section 45125.1)

Other than business entities performing construction, reconstruction, rehabilitation, or repair who have complied with Education Code section 45125.2, business entities entering into contracts with the District must comply with Education Code sections 45125.1. Such entities are responsible for ensuring full compliance with the law and should therefore review all applicable statutes and regulations. The following information is provided simply to assist such entities with compliance with the law:

1. You (as a business entity) shall ensure that each of your employees who interacts with pupils outside of the immediate supervision and control of the pupil's parent or guardian or a school employee has a valid criminal records summary as described in Education Code section 44237. (Education Code §45125.1(a).) You shall do the same for any other employees as directed by the District. (Education Code §45125.1(c).) When you perform the criminal background check, you shall immediately provide any subsequent arrest and conviction information it receives to the District pursuant to the subsequent arrest service. (Education Code §45125.1(a).)

2. You shall not permit an employee to interact with pupils until the Department of Justice has ascertained that the employee has not been convicted of a felony as defined in Education Code section 45122.1. (Education Code §45125.1(e).) See the lists of violent and serious felonies in **Attachment A** to this Notice.

3. Prior to performing any work or services under your contract with the District, and prior to being present on District property or being within the vicinity of District pupils, you shall certify in writing to the District under the penalty of perjury that neither the employer nor any of its employees who are required to submit fingerprints, and who may interact with pupils, have been convicted of a felony as defined in Education Code section 45122.1, and that you are in full compliance with Education Code section 45125.1. (Education Code §45125.1(f).) For this certification, you shall use the form in **Attachment B** to this Notice.

4. If you are providing the above services in an emergency or exceptional situation, you are not required to comply with Education Code section 45125.1, above. An "emergency or exceptional" situation is one in which pupil health or safety is endangered or when repairs are needed to make a facility safe and habitable. The District shall determine whether an emergency or exceptional situation exists. (Education Code §45125.1(b).)

5. If you are an individual operating as a sole proprietor of a business

entity, you are considered an employee of that entity for purposes of Education Code section 45125.1, and the District shall prepare and submit your fingerprints to the Department of Justice as described in Education Code section 45125.1(a). (Education Code §45125.1(h).)

I, as _____ *[insert "owner" or officer title]* of _____ *[insert name of business entity]*, have read the foregoing and agree that _____ *[insert name of business entity]* will comply with the requirements of Education Code §45125.1 as applicable, including submission of the certificate mentioned above.

Dated: _____

Name: _____

Signature: _____

Title: _____

Page intentionally left blank

ATTACHMENT A

Violent and Serious Felonies

Under Education Code sections 45122.1 and 45125.1, no employee of a contractor or subcontractor who has been convicted of or has criminal proceedings pending for a violent or serious felony may come into contact with any student. A violent felony is any felony listed in subdivision (c) of Section 667.5 of the Penal Code. Those felonies are presently defined as:

- (1) Murder or voluntary manslaughter.
- (2) Mayhem.
- (3) Rape as defined in paragraph (2) or (6) of subdivision (a) of Section 261 or paragraph (1) or (4) of subdivision (a) of Section 262.
- (4) Sodomy as defined in subdivision (c) or (d) of Section 286.
- (5) Oral copulation as defined in subdivision (c) or (d) of Section 288a.
- (6) Lewd or lascivious act as defined in subdivision (a) or (b) of Section 288.
- (7) Any felony punishable by death or imprisonment in the state prison for life.
- (8) Any felony in which the defendant inflicts great bodily injury on any person other than an accomplice which has been charged and proved as provided for in Section 12022.7, 12022.8, or 12022.9 on or after July 1, 1977, or as specified prior to July 1, 1977, in Sections 213, 264, and 461, or any felony in which the defendant uses a firearm which use has been charged and proved as provided in subdivision (a) of Section 12022.3, or Section 12022.5 or 12022.55.
- (9) Any robbery.
- (10) Arson, in violation of subdivision (a) or (b) of Section 451.
- (11) Sexual penetration as defined in subdivision (a) or (j) of Section 289.
- (12) Attempted murder.
- (13) A violation of Section 18745, 18750, or 18755.
- (14) Kidnapping.
- (15) Assault with the intent to commit a specified felony, in violation of Section 220.
- (16) Continuous sexual abuse of a child, in violation of Section 288.5.
- (17) Carjacking, as defined in subdivision (a) of Section 215.
- (18) Rape, spousal rape, or sexual penetration, in concert, in violation of Section 264.1.

(19) Extortion, as defined in Section 518, which would constitute a felony violation of Section 186.22 of the Penal Code.

(20) Threats to victims or witnesses, as defined in Section 136.1, which would constitute a felony violation of Section 186.22 of the Penal Code.

(21) Any burglary of the first degree, as defined in subdivision (a) of Section 460, wherein it is charged and proved that another person, other than an accomplice, was present in the residence during the commission of the burglary.

(22) Any violation of Section 12022.53.

(23) A violation of subdivision (b) or (c) of Section 11418.

A serious felony is any felony listed in subdivision (c) Section 1192.7 of the Penal Code. Those felonies are presently defined as:

(1) Murder or voluntary manslaughter; (2) Mayhem; (3) Rape; (4) Sodomy by force, violence, duress, menace, threat of great bodily injury, or fear of immediate and unlawful bodily injury on the victim or another person; (5) Oral copulation by force, violence, duress, menace, threat of great bodily injury, or fear of immediate and unlawful bodily injury on the victim or another person; (6) Lewd or lascivious act on a child under the age of 14 years; (7) Any felony punishable by death or imprisonment in the state prison for life; (8) Any felony in which the defendant personally inflicts great bodily injury on any person, other than an accomplice, or any felony in which the defendant personally uses a firearm; (9) Attempted murder; (10) Assault with intent to commit rape, or robbery; (11) Assault with a deadly weapon or instrument on a peace officer; (12) Assault by a life prisoner on a non-inmate; (13) Assault with a deadly weapon by an inmate; (14) Arson; (15) Exploding a destructive device or any explosive with intent to injure; (16) Exploding a destructive device or any explosive causing bodily injury, great bodily injury, or mayhem; (17) Exploding a destructive device or any explosive with intent to murder; (18) Any burglary of the first degree; (19) Robbery or bank robbery; (20) Kidnapping; (21) Holding of a hostage by a person confined in a state prison; (22) Attempt to commit a felony punishable by death or imprisonment in the state prison for life; (23) Any felony in which the defendant personally used a dangerous or deadly weapon; (24) Selling, furnishing, administering, giving, or offering to sell, furnish, administer, or give to a minor any heroin, cocaine, phencyclidine (PCP), or any methamphetamine-related drug, as described in paragraph (2) of subdivision (d) of Section 11055 of the Health and Safety Code, or any of the precursors of methamphetamines, as described in subparagraph (A) of paragraph (1) of subdivision (f) of Section 11055 or subdivision (a) of Section 11100 of the Health and Safety Code; (25) Any violation of subdivision (a) of Section 289 where the act is accomplished against the victim's will by force, violence, duress, menace, or fear of immediate and unlawful bodily injury on the victim or another person; (26) Grand theft involving a firearm; (27) carjacking; (28) any felony offense, which would also constitute a felony violation of Section 186.22; (29) assault with the intent to commit mayhem, rape, sodomy, or oral copulation, in violation of Section 220; (30) throwing acid or flammable substances, in violation of Section 244; (31) assault with a deadly weapon, firearm, machine gun, assault weapon, or semiautomatic firearm or assault on a peace officer or firefighter, in violation of Section 245; (32) assault with a deadly weapon against a public transit employee, custodial officer, or school employee, in violation of Sections 245.2, 245.3, or 245.5; (33) discharge of a firearm at an inhabited dwelling, vehicle, or aircraft, in violation of Section 246; (34) commission of rape or sexual penetration in concert with another person, in violation of Section 264.1; (35) continuous sexual abuse of a child, in violation of Section 288.5; (36) shooting from a vehicle, in violation of subdivision (c) or (d) of Section 26100; (37) intimidation of victims or witnesses, in violation of Section 136.1; (38) criminal threats, in violation of Section 422; (39) any attempt to commit a crime listed in this subdivision other than an assault; (40) any violation of Section 12022.53; (41) a violation of subdivision (b) or (c) of Section 11418; and (42) any conspiracy to commit an offense described in this subdivision.

ATTACHMENT B

Form for Certification of Lack of Felony Convictions

Note: This form must be submitted by the owner, or an officer, of the contracting entity before it may commence any work or services, and before it may be present on District property or be within the vicinity of District pupils.

Entity Name: _____

Date of Entity’s Contract with District: _____

Scope of Entity’s Contract with District: _____

I, _____ [*insert name*] , am the _____ [*insert “owner” or officer title*] for _____ [*insert name of business entity*] (“Entity”), which entered a contract on _____, 20__, with the District for _____.

I certify that (1) pursuant to Education Code section 45125.1(f), neither the Entity, nor any of its employees who are required to submit fingerprints and who may interact with pupils, have been convicted of a felony as defined in Education Code section 45122.1; and (2) the Entity is in full compliance with Education Code section 45125.1, including but not limited to each employee who will interact with a pupil outside of the immediate supervision and control of the pupil’s parent or guardian having a valid criminal background check as described in Education Code section 44237.

I declare under penalty of perjury that the foregoing is true and correct to the best of my knowledge.

Date: _____, 20__

Signature: _____

Typed Name: _____

Title: _____

Entity: _____

Certificate of Independent Price Determination - Attachment "13"

TO BE SUBMITTED WITH PROPOSAL

Both the SFA and Bidder shall execute this Certificate of Independent Price Determination.

Name of Bidder		Name of SFA

1. By submission of this offer, the offeror (Bidder) certifies and, in the case of a joint offer, each party thereto certifies as to its own organization that in connection with this procurement:
 - a. The prices in this offer have been arrived at independently—without consultation, communication, or agreement—for the purpose of restricting competition, as to any matter relating to such prices with any other offeror or with any competitor;
 - b. Unless otherwise required by law, the prices which have been quoted in this offer have not been knowingly disclosed by the offeror and will not knowingly be disclosed by the offeror prior to opening the case of an advertised procurement, directly or indirectly to any other offeror or to any competitor; and
 - c. No attempt has been made or will be made by the offeror to induce any person or firm to submit, or not to submit, an offer for the purpose of restricting competition.
2. Each person signing this offer on behalf of the offeror certifies that:
 - a. He or she is the person in the offeror’s organization responsible within the organization for the decision as to the prices being offered herein and has not participated, and will not participate, in any action contrary to (1)(a) through (1)(c) above; or
 - b. He or she is not the person in the offeror’s organization responsible within the organization for the decision as to the prices being offered herein, but that he or she has been authorized in writing to act as agent for the persons responsible for such decision in certifying that such persons have not participated, and will not participate, in any action contrary to (1)(a) through (1)(c) above and as their agent does hereby so certify; and he or she has not participated, and will not participate, in any action contrary to (1)(a) through (1)(c) above.

To the best of my knowledge, this vendor and its affiliates, subsidiaries, officers, directors, and employees are not currently under investigation by any governmental agency and have not in the last three years been convicted or found liable for any act prohibited by state or federal law in any jurisdiction, involving conspiracy or collusion with respect to bidding on any public contract, except as follows (provide detail):

Signature of Bidder's Authorized Representative		Title		Date

In accepting this offer, the SFA certifies that no representative of the SFA has taken any action that may have jeopardized the independence of the offer referred to above.

Signature of SFA's Authorized Representative		Title		Date

Suspension And Debarment Certification - Attachment "14"
TO BE SUBMITTED WITH PROPOSAL

INSTRUCTIONS: SFA to obtain from any potential vendor or existing contractor for all contracts in excess of \$100,000. This form is required each time a Proposal for goods/services over \$100,000 is solicited or when renewing/extending an existing contract exceeding \$100,000 per year (Includes Food Service Management and Food Service Consulting Contracts).

**Certification Regarding Debarment, Suspension, Ineligibility and Voluntary Exclusion
Lower Tier Covered Transactions**

This certification is required by the regulations implementing Executive Order 12549, Debarment and Suspension, 7 CFR Part 3017, Section 3017.510, Participants' responsibilities. The regulations were published as Part IV of the January 30, 1989, Federal Register (pages 4722 – 4733). Copies of the regulations may be obtained by contacting the Department of Agriculture agency with which this transaction originated.

**(BEFORE COMPLETING CERTIFICATION,
READ INSTRUCTIONS ON THE FOLLOWING PAGE)**

1. The prospective lower tier participant certifies, by submission of this proposal, that neither it nor its principals is presently debarred, suspended, proposed for debarment, declared ineligible, or voluntarily excluded from participation in this transaction by any Federal department or agency.
2. Where the prospective lower tier participant is unable to certify to any of the statements in this certification, such prospective participant shall attach an explanation to this proposal.

Name of School Food Authority

Agreement Number

Potential Vendor or Existing Contractor (Lower Tier Participant):

Printed Name

Title

Signature

Date

**DO NOT SUBMIT THIS FORM RETAIN WITH THE APPLICABLE CONTRACT OR PROPOSAL
RESPONSES.**
INSTRUCTIONS FOR CERTIFICATION

1. By signing and submitting this form, the prospective lower tier participant (one whose contract for goods or services exceeds the Federal procurement small purchase threshold fixed at \$100,000) is providing the certification set out on the reverse side in accordance with these instructions.
2. The certification in this clause is a material representation of fact upon which reliance was placed when this transaction was entered into. If it is later determined that the prospective lower tier participant knowingly rendered an erroneous certification, in addition to other remedies available to the Federal Government, the department or agency with which this transaction originated may pursue available remedies, including suspension and/or debarment.
3. The prospective lower tier participant shall provide immediate written notice to the person to which this proposal is submitted if at any time the prospective lower tier participant learns that its certification was erroneous when submitted or has become erroneous by reason of changed circumstances.
4. The terms “covered transaction,” “debarred,” “suspended,” “ineligible,” “lower tier covered transaction,” “participant,” “person,” “primary covered transaction,” “principal,” “proposal,” and “voluntarily excluded,” as used in this clause, have the meanings set out in the Definitions and Coverage sections of rules implementing Executive Order 12549. You may contact the person to which this proposal is submitted for assistance in obtaining a copy of those regulations.
5. The prospective lower tier participant agrees by submitting this form that, should the proposed covered transaction be entered into, it shall not knowingly enter into any lower tier covered transaction with a person who is debarred, suspended, declared ineligible, or voluntarily excluded from participation in this covered transaction, unless authorized by the department or agency with which this transaction originated.
6. The prospective lower tier participant further agrees by submitting this form that it will include this clause titled “Certification Regarding Debarment, Suspension, Ineligibility and Voluntary Exclusion – Lower Tier Covered Transactions,” without modification, in all lower tier covered transactions and in all solicitations for lower tier covered transactions.
7. A participant in a covered transaction may rely upon a certification of a prospective participant in a lower tier covered transaction that it is not debarred, suspended, ineligible, or voluntarily excluded from the covered transaction, unless it knows that the certification is erroneous. A participant may decide the method and frequency by which it determines the eligibility of its principals. Each participant may, but is not required to, check the Nonprocurement List.
8. Nothing contained in the foregoing shall be construed to require establishment of a system of records in order to render in good faith the certification required by this clause. The knowledge and information of a participant is not required to exceed that which is normally possessed by a prudent person in the ordinary course of business dealings.
9. Except for transactions authorized under paragraph 5 of these instructions, if a participant in a covered transaction knowingly enters into a lower tier covered transaction with a person who is suspended, debarred, ineligible, or voluntarily excluded from participation in this transaction, in addition to other remedies available to the Federal Government, the department or agency with which this transaction originated may pursue available remedies, including suspension and/or debarment.

Certification Regarding Lobbying - Attachment "15"

TO BE SUBMITTED WITH PROPOSAL

INSTRUCTIONS: To be completed and submitted ANNUALLY by (1) any child nutrition entity receiving Federal reimbursement in excess of \$100,000 per year and (2) potential or existing contractors/Vendors as part of an original Proposal, contract renewal or extension when the contract exceeds \$100,000.

Applicable to Grants, Subgrants, Cooperative Agreements, and Contracts
Exceeding \$100,000 in Federal Funds

Submission of this certification is a prerequisite for making or entering into this transaction and is imposed by section 1352, Title 31, U.S. Code. This certification is a material representation of fact upon which reliance was placed when this transaction was made or entered into. Any person who fails to file the required certification shall be subject to a civil penalty of not less than \$10,000 and not more than \$100,000 for each such failure.

The undersigned certifies, to the best of his or her knowledge and belief, that:

- (1) No Federal appropriated funds have been paid or will be paid by or on behalf of the undersigned, to any person for influencing or attempting to influence an officer or employee of any agency, a Member of Congress, an officer or employee of Congress, or an employee of a Member of Congress in connection with the awarding of a Federal contract, the making of a Federal grant, the making of a Federal loan, the entering into a cooperative agreement, and the extension, continuation, renewal, amendment, or modification of a Federal contract, grant, loan, or cooperative agreement.
- (2) If any funds other than Federal appropriated funds have been paid or will be paid to any person for influencing or attempting to influence an officer or employee of any agency, a Member of Congress, an officer or employee of Congress, or an employee of a Member of Congress in connection with this Federal grant or cooperative agreement, the undersigned shall complete and submit Standard Form-LLL, "Disclosure Form to Report Lobbying," in accordance with its instructions.
- (3) The undersigned shall require that the language of this certification be included in the award documents for all covered subawards exceeding \$100,000 in Federal funds at all appropriate tiers and that all subrecipients shall certify and disclose accordingly.

Name of School Food Authority Receiving Child Nutrition Reimbursement In Excess of \$100,000:	Agreement Number:	
Address of School Food Authority:		
Printed Name and Title of Submitting Official:	Signature :	Date:
OR		
Name of Vendor:		
Printed Name and Title:	Signature :	Date:

DISCLOSURE OF LOBBYING ACTIVITIES

Complete this form to disclose lobbying activities pursuant to 31 U.S.C. 1352 0348-0046

<p>1. Type of Federal Action:</p> <p>a. contract b. grant c. cooperative agreement d. loan e. loan guarantee f. loan insurance</p>	<p>2. Status of Federal Action:</p> <p>a. bid/offer/application b. initial award c. post-award</p>	<p>3. Report Type:</p> <p>a. initial filing b. material change</p> <p>For material change only: Year ____ quarter ____</p> <p>Date of last report _____</p>
<p>4. Name and Address of Reporting Entity:</p> <p>____ Prime ____ Subawardee Tier____, if Known:</p> <p>Congressional District, if known:</p>		<p>5. If Reporting Entity in No. 4 is Subawardee, Enter Name and Address of Prime:</p> <p>Congressional District, if known:</p>
<p>6. Federal Department/Agency:</p>	<p>7. Federal Program Name/Description:</p> <p>CFDA Number, if applicable: _____</p>	
<p>8. Federal Action Number, if known:</p>	<p>9. Award Amount, if known:</p> <p style="text-align: center;">\$</p>	
<p>10. a. Name and Address of Lobbying Registrant <i>(if individual, last name, first name, MI):</i></p>	<p>10. b. Individuals Performing Services <i>(including address if different from No. 10a) (last name, first name, MI):</i></p>	
<p>11. Information requested through this form is authorized by title 31 U.S.C. section 1352. This disclosure of lobbying activities is a material representation of fact upon which reliance was placed by the tier above when this transaction was made or entered into. This disclosure is required pursuant to 31 U.S.C. 1352. This information will be reported to the Congress semi-annually and will be available for public inspection. Any person who fails to file the required disclosure shall be subject to a civil penalty of not less than \$10,000 and not more than \$100,000 for each such failure.</p>	<p>Signature:</p> <p>Print Name:</p> <p>Title:</p> <p>Telephone No.:</p> <p>Date:</p>	
<p>Federal Use Only</p>	<p>Authorized for Local Reproduction Standard Form - LLL (Rev. 7-97)</p>	

INSTRUCTIONS FOR COMPLETION OF SF-LLL, DISCLOSURE OF LOBBYING ACTIVITIES

This disclosure form shall be completed by the reporting entity, whether subawardee or prime Federal recipient, at the initiation or receipt of a covered Federal action, or a material change to a previous filing, pursuant to title 31 U.S.C. section 1352. The filing of a form is required for each payment or agreement to make payment to any lobbying entity for influencing or attempting to influence an officer or employee of any agency, a Member of Congress, an officer or employee of Congress, or an employee of a Member of Congress in connection with a covered Federal action. Complete all items that apply for both the initial filing and material change report. Refer to the implementing guidance published by the Office of Management and Budget for additional information.

1. Identify the type of covered Federal action for which lobbying activity is and/or has been secured to influence the outcome of a covered Federal action.
2. Identify the status of the covered Federal action.
3. Identify the appropriate classification of this report. If this is a followup report caused by a material change to the information previously reported, enter the year and quarter in which the change occurred. Enter the date of the last previously submitted report by this reporting entity for this covered Federal action.
4. Enter the full name, address, city, State and zip code of the reporting entity. Include Congressional District, if known. Check the appropriate classification of the reporting entity that designates if it is, or expects to be, a prime or subaward recipient. Identify the tier of the subawardee, e.g., the first subawardee of the prime is the 1st tier. Subawards include but are not limited to subcontracts, subgrants and contract awards under grants.
5. If the organization filing the report in item 4 checks "Subawardee," then enter the full name, address, city, State and zip code of the prime Federal recipient. Include Congressional District, if known.
6. Enter the name of the federal agency making the award or loan commitment. Include at least one organizational level below agency name, if known. For example, Department of Transportation, United States Coast Guard.
7. Enter the Federal program name or description for the covered Federal action (item 1). If known, enter the full Catalog of Federal Domestic Assistance (CFDA) number for grants, cooperative agreements, loans, and loan commitments.
8. Enter the most appropriate Federal identifying number available for the Federal action identified in item 1 (e.g., Request for Proposal (RFP) number; Invitations for Bid (IFB) number; grant announcement number; the contract, grant, or loan award number; the application/proposal control number assigned by the Federal agency). Included prefixes, e.g., "RFP-DE-90-001."
9. The certifying official shall sign and date the form, print his/her name, title, and telephone number.
10. For a covered Federal action where there has been an award or loan commitment by the Federal agency, enter the Federal amount of the award/loan commitment for the prime entity identified in item 4 or 5.
11.
 - a. Enter the full name, address, city, State and zip code of the lobbying registrant under the Lobbying Disclosure Act of 1995 engaged by the reporting entity identified in item 4 to influence the covered Federal action.
 - b. Enter the full names of the individual(s) performing services, and include full address if different from 10(a). Enter Last Name, First Name, and Middle Initial (MI).

According to the Paperwork Reduction Act, as amended, no persons are required to respond to a collection of information unless it displays a valid OMB control Number. The valid OMB control number for this information collection is OMB No. 0348-0046. Public reporting burden for this collection of information is estimated to average 10 minutes per response, including time for reviewing instructions, searching existing data sources, gathering and maintaining the data needed, and completing and reviewing the collection of information. Send comments regarding the burden estimate or any other aspect of this collection of information, including suggestions for reducing this burden, to the Office of Management and Budget, Paperwork Reduction Project (0348-0046), Washington, DC 20503

Iran Contracting Act Of 2010 Compliance Affidavit - Attachment "16"

TO BE SUBMITTED WITH PROPOSAL

The California Legislature adopted the Iran Contracting Act of 2010 to respond to policies of Iran in a uniform fashion (PCC § 2201(q)). The Iran Contracting Act prohibits Bidders engaged in investment activities in Iran from bidding on, submitting proposals for, or entering into or renewing contracts with public entities for goods and services of one million dollars (\$1,000,000) or more (PCC § 2203(a)). A Bidder who "engages in investment activities in Iran" is defined as either:

1. A Bidder providing goods or services of twenty million dollars (\$20,000,000) or more in the energy sector of Iran, including provision of oil or liquefied natural gas tankers, or products used to construct or maintain pipelines used to transport oil or liquefied natural gas, for the energy sector of Iran; or
2. A Bidder that is a financial institution (as that term is defined in 50 U.S.C. § 1701) that extends twenty million dollars (\$20,000,000) or more in credit to another person, for 45 days or more, if that person will use the credit to provide goods or services in the energy sector in Iran and is identified on a list created by the California Department of General Services (DGS) pursuant to PCC § 2203(b) as a person engaging in the investment activities in Iran.

The Bidder shall certify that at the time of submitting a Proposal for new contract or renewal of an existing contract, the Bidder is not identified on the DGS list of ineligible businesses or persons and that the Bidder is not engaged in investment activities in Iran in violation of the Iran Contracting Act of 2010.

California law establishes penalties for providing false certifications, including civil penalties equal to the greater of \$250,000 or twice the amount of the contract for which the false certification was made; contract termination; and three-year ineligibility to bid on contracts (PCC § 2205).

To comply with the Iran Contracting Act of 2010, the Bidder shall provide its vendor or financial institution name, and City Business Tax Registration Certificate (BTRC) if available, in completing **ONE** of the options shown below.

OPTION #1: CERTIFICATION

I, the official named below, certify that I am duly authorized to execute this certification on behalf of the Bidder or financial institution identified below, and that the Bidder or financial institution identified below is not on the current DGS list of persons engaged in investment activities in Iran and is not a financial institution extending twenty million dollars (\$20,000,000) or more in credit to another person or vendor, for 45 days or more, if that other person or vendor will use the credit to provide goods or services in the energy sector in Iran and is identified on the current DSG list of persons engaged in investment activities in Iran.

Vendor Name/Financial Institution (printed)	BTRC (or n/a)
By (Authorized Signature)	
Print Name and Title of Person Signing	
Date Executed	City Approval (Signature) (Print Name)

OPTION #2: EXEMPTION

Pursuant to PCC § 2203(c) and (d), a public entity may permit a Bidder or financial institution engaged in investment activities in Iran, on a case-by-case basis, to be eligible for, or to bid on, submit a proposal for, or enter into, or renew, a contract for goods and services. If the Bidder or financial institution identified below has obtained an exemption from the certification requirement under the Iran Contracting Act of 2010, the Bidder or financial institution shall complete and sign below and attach documentation demonstrating the exemption approval.

Vendor Name/Financial Institution (printed)	BTRC (or n/a)	
By (Authorized Signature)		
Print Name and Title of Person Signing		
Date Executed	City Approval (Signature)	(Print Name)

Clean Air And Water Certification - Attachment "17"

TO BE SUBMITTED WITH PROPOSAL

Applicable if the contract exceeds \$100,000 or the Contracting Officer has determined that the orders under an indefinite quantity contract in any one year will exceed \$100,000 or a facility to be used has been the subject of a conviction under the Clean Air Act (41 U.S.C. 1857c-8(c)(1) or the Federal Water Pollution Control Act 33 1319(d) and is listed by EPA or the contract is not otherwise exempt.

Name of Vendor Company

THE VENDOR AGREES AS FOLLOWS:

- A. To comply with all the requirements of Section 114 of the Clean Air Act, as amended (41 U.S.C. 1857, et seq., as amended by Public Law 91-604) and Section 308 of the Federal Water Pollution Control Act (33 U.S.C. 1251, et seq., as amended by Public Law 92-500), respectively, relating to inspection, monitoring, entry, reports and information as well as other requirements specified in Section 114 and Section 308 of the Air Act and the Water Act, respectively, and all regulations and guidelines issued there under before the award of this contract.
- B. That no portion of the work required by this prime contract will be performed in a facility listed on the Environmental Protection Agency List of Violating Facilities on the date when this contract was awarded unless and until the EPA eliminates the name of such facility or facilities from such listing.
- C. To use his/her best efforts to comply with clean air standards and clean water standards at the facilities in which the contract is being performed.
- D. To insert the substance of the provisions of this clause in any nonexempt subcontract, including this paragraph.

THE TERMS IN THIS CLAUSE HAVE THE FOLLOWING MEANINGS:

- A. The term "Air Act" means the Clean Air Act, as amended (41 U.S.C. 1957 et seq., as amended by Public Law 91-604).
- B. The term "Water Act" means Federal Water Pollution Control Act, as amended (33 U.S.C. 1251 et seq., as amended by Public Law 92-500).
- C. The term "Clean Air Standards" means any enforceable rules, regulations, guidelines, standards, limitations, orders, controls, prohibitions, or other requirements which are contained in, issued under, or otherwise adopted pursuant to the Air Act or Executive Order 11738, an applicable implementation plan as described in section 110(d) of the Clean Air Act (42 U.S.C. 1957c-5(d)), an approved implementation procedure or plan under Section 111(c) or Section 111(d), respectively, of the Air Act (42 U.S.C. 1857c-6(c) or (d)), or approved implementation procedure under Section 112(d) of the Air Act (42 U.S.C. 1857c-7(d)).
- D. The term "Clean Air Standards" means any enforceable limitation, control, condition, prohibition, standard, or other requirement which is promulgated pursuant to the Water Act or contained in a permit issued to a discharger by the Environmental Protection Agency or by a State under an approved program, as authorized by Section 402 of the Water Act (33 U.S.C. 1342) or by local government to ensure compliance with pretreatment regulations as required by Section 307 of the Water Act (33 U.S.C. 1317).
- E. The term "Compliance" means compliance with clean air or water standards. Compliance shall also mean compliance with a schedule or plan ordered or approved by a court of competent jurisdiction, the Environmental Protection Agency or an Air or Water Pollution Control Agency in accordance with the requirements of the Air Act or Water Act and regulations issued pursuant thereto.
- F. The term "facility" means any building, plant, installation, structure, mine, vessel, or other floating craft, location or sites of operations, owned, leased or supervised by the Food Service Management Company.

Authorized Representative

Title

Date