

Board Office Use: Legislative File Info.	
File ID Number	24-2981
Introduction Date	1-8-2025
Enactment Number	24-2383
Enactment Date	1/8/2025 CJH



Memo

To Board of Education

From Kyla Johnson-Trammell, Superintendent
Preston Thomas, Chief Systems and Services Officer
Kenya Chatman, Executive Director, Facilities

Board Meeting Date January 8, 2025

Subject Change Order No. 1 to Agreement Between Owner and Contractor – Arntz Builders, Inc. – Claremont Middle School Multi-Purpose Room & Kitchen Project –Division of Facilities Planning and Management

Action Requested Approval by the Board of Education of Change Order No. 1 to Agreement Between Owner and Contractor, by and between the **District and Arntz Builders, Inc.**, Petaluma, CA, for additional construction services to cover construction work that was not reflected in the construction drawings, which includes the approval of PCO's 1 through 10, for the construction of a new two-story building for the **Claremont Middle School Multi-Purpose Room & Kitchen Project**, in the not-to-exceed amount of **\$72,307.84**, increasing the contract price from **\$15,985,725.00 to \$16,058,032.84**, and extending the term of the Agreement by an additional 48 calendar days, from May 26, 2022 through August 31, 2023, to October 18, 2023. All other terms and conditions of the Agreement remain in full force and effect.

Discussion This Change Order is for Claremont Middle School Multi-Purpose Room & Kitchen Project, for additional construction services which includes PCO's 1 through 10 to be approved for various contract changes.

LBP (Local Business Participation Percentage) 56.1%

Recommendation Approval by the Board of Education of Change Order No. 1 to Agreement Between Owner and Contractor, by and between the District and Arntz Builders, Inc., Petaluma, CA, for additional construction services to cover construction work that was not reflected in the construction drawings which includes the approval of PCO's 1 through 10, for the construction of a new two-story building for the Claremont Middle School Multi-Purpose Room & Kitchen Project, in the not-to-exceed amount of \$72,307.84, increasing the contract price from \$15,985,725.00 to \$16,058,032.84, and extending the term of the Agreement by an additional 48 calendar days, from May 26, 2022, through August 31, 2023 to October 18, 2023. All other terms and conditions of the Agreement remain in full force and effect.

Fiscal Impact Fund 21 Building Fund, Measure Y

Attachments

- Change Order No. 1, and Other Documents
- Routing Form
- File ID 22-1167

**LOCAL BUSINESS PARTICIPATION WORKSHEET -
LBU Modification / Amendment**



PRIME: Arntz Builders, Inc.	Original Contract Amount (Base Bid):	\$14,685,725
Project: Claremont MPR	Originally Proposed LBU %:	66%
Project #: 15127	Amendment/Change Order No.: CO 1	\$72,307.84
Project Manager: Robert Arntz	Total Contract Amount (Amended Contract, to Date):	\$16,058,032.84
	Proposed LBU %	

Amended Contract Value:					
	\$ 16,058,032.84				
	Total Dollar Amount of Work	LBE %	SLBE%	SLBRE%	
Tulum	\$ 1,989,640.71		13.5%		
Broadway Mechanical	\$ 1,177,573.48		8.0%		
Focon Inc	\$ 1,019,981.00		6.9%		
Light Frame	\$ 3,080,714.00		21.0%		
Hartley	\$ 380,616.00		2.6%		
Brite Painting	\$ 83,603.00		0.6%		
Asbestos Management Group	\$ 45,000.00		0.3%		
Cooper Construction	\$ 28,000.00		0.2%		
RMT	\$ 93,256.00		0.6%		
ACR Glass	\$ 333,944.00		2.3%		
Phone:					
	\$8,232,328.19	0.0%	56.1%	0.0%	56.1%

APPROVAL - LBU Compliance Officer

Note: Local Business Participation documentation must be approved and included in contract amendment documentation, where LBU impacted.



Updated by 360 Total Concept - Nov 2023

OAKLAND UNIFIED SCHOOL DISTRICT

Division of Facilities Planning and Management • 955 High Street Oakland, California 94601 • Phone 510/535-2728

CHANGE ORDER

For Design-Bid-Build Contract

Owner: Oakland Unified School District
Project: Claremont Middle School Multi-Purpose Building & Kitchen
School: Claremont Middle School
Contractor: Arntz Builders Inc.

Change Order No.: 1

Date: September 25, 2024

DSA File No.: 01-119337
DSA Application No.: 01-119337
OUSD Project #: 15127
Project Manager: Jaquan Cornish

IF NOT PREVIOUSLY DIRECTED, THE CONTRACTOR IS HEREBY DIRECTED TO PERFORM THE WORK REQUIRED BY THIS CHANGE ORDER AND ITS ATTACHMENTS, INCLUDING BUT NOT LIMITED TO THE SUMMARY, THE RELEVANT CORs OR PCOs, AND THE BACKUP DOCUMENTATION FOR THE CORs AND PCOs.

DESCRIPTION OF AGREED CHANGES IN WORK OR CONTRACT (refer to attached pages or incorporated documents, if necessary):

PCO 27 – Face of Stage Finish (Error): There was no call out for what the face of stage finish should be. AOR’s RFI response clarified a furred gyp wall. The face of gyp board was installed flush with adjacent wall. - \$2,153.35

PCO 58 – Extended General Conditions (Unforeseen): Arntz submitted a Time Impact Analysis identifying the delays and number of days. The analysis was reviewed and approved by the district - 48 Additional Calendar Days

PCO 75 – Site Work Acceleration (Owner’s Request): Due to unforeseen conditions throughout the site, contract work was delayed. Extended workdays and weekend work was performed to be completed before start of school date August 7th, 2023. - \$21,446.67

OAKLAND UNIFIED SCHOOL DISTRICT

Division of Facilities Planning and Management • 955 High Street Oakland, California 94601 • Phone 510/535-2728

PCO 97 – Existing RWL Re-Route (Unforeseen): An existing pipe was found damage while excavating for the new electrical trench. It was found this line was a RWL serving the high roof of Building B. The line was rerouted per RFI 309 direction. - \$7,424.40

PCO 120 – Barrier Fencing Near Building B. (Site Request): Site Staff requested fencing barrier for students' safety. Added fencing adjacent to Building B and between canopy columns C-A & C-B per attached sketches in ASI 20. - \$16,788.44

PCO 128 – Cat 6A Cables for Windows Actuators (Error): Per RFI 337 response: Provide (2) Cat. 6A cables to window actuators controller, one for each controller. Homerun cables in the same conduit serving the telephone wall outlet in Storage Room 4. Provide additional conduit and j-boxes as needed to extend conduit down the north wall. Coordinate termination in the window actuator controllers with Controls Contractor. Detail was not reflected in the electrical drawings. - \$2,999.48

PCO 139 – Set Up Transformers for Vertical Lift Doors (Omission): The contract electrical requirements are not sufficient for the vertical lift doors. Per RFI 444R1 response, provide a total of (3) buck-boost transformers, wired as autotransformer to boost from source voltage of 208V to load voltage of 240V, single phase, to meet the vertical lift door's operating voltage requirement. - \$7,733.11

PCO 143 – Gutters at (E) Gym Canopy (Unforeseen): Costs associated with the gutters that were added to the roof of the (E) gym canopy. Detail was not reflected in the project drawings -\$1,827

PCO 144 – Added Signage Type S19 (Omission): Signage type S19 was added in ASI 27, resulting in additional costs. - \$1,359.13

PCO 146 – Replace Gym FA Devices (Unforeseen): Per Enrico with OUSD Fire Alarm Shop and Johnson Control Inc., the replacement of Fire Alarm devices in the old gym is required resulting in an additional cost. - \$10,576.26

TOTAL ADJUSTMENT TO CONTRACT PRICE BY THIS CHANGE ORDER: \$72,307.84

TOTAL ADJUSTMENT TO CONTRACT TIME BY THIS CHANGE ORDER: 48 calendar days

OAKLAND UNIFIED SCHOOL DISTRICT

Division of Facilities Planning and Management • 955 High Street Oakland, California 94601 • Phone 510/535-2728

SUMMARY OF ADJUSTMENTS TO CONTRACT PRICE:

Original Contract Price (include all special and contingency allowances):	\$15,985,725
Prior Change Orders:	+ \$0
Total Contract Price Prior to this Change Order	= \$15,985,725
This Change Order's Adjustment:	+ \$72,307.84
Adjusted Contract Price (include all special and contingency allowances):	= \$16,058,032.84
Current Change Order's Percentage of Original Contract Price:	.45%
Total Change Orders' Percentage of Original Contract Price:	.45%

NOTE: Any unspent allowance amounts (including any contingency allowance) shall be retained by the Owner at the end of the Contract. To process an allowance expenditure, use the Allowance Expenditure Directive form, which requires signatures of Contractor and Owner, but does not require Board approval.

SUMMARY OF ADJUSTMENTS TO TIME FOR COMPLETION:

Original contract time:	434 Calendar Days
Prior change order adjustments to contract time:	+ 0 Calendar Days
This change order's adjustment to contract time:	+ 48 Calendar Days
Adjusted contract time:	= 482 Calendar Days

Start Date per Notice to Proceed:	May 26, 2022
Completion Deadline Based on Adjusted Contract Time:	October 18, 2023

OAKLAND UNIFIED SCHOOL DISTRICT

Division of Facilities Planning and Management • 955 High Street Oakland, California 94601 • Phone 510/535-2728

The compensation (time and cost) set forth in this change order comprises the total compensation due the Contractor for the change defined in the change order, including extra work and impact on unchanged work. Acceptance of this change order by Contractor constitutes a full and complete accord and satisfaction of any and all claims by Contractor arising out of or relating to the work and issues covered by the change order, including but not limited to claims for the following: Costs to perform the work; contract balance; contract retention; time; extended field, home office, and other overhead; acceleration, impact, disruption, and delay damages; any and all direct and indirect costs; claims by subcontractors and suppliers; and any and all other requests to the Owner for time or money, from any source and under any legal theory whatsoever, as to the subject of this change order. No signature under protest or accompanied by reservation of rights or protest language, or any other attempts to avoid such waiver shall be of any force or effect whatsoever. No additions or deletions to this change order shall be allowed, except with the approval of Owner's governing body. No language contained in backup material to any change order shall constitute a waiver of anything in this paragraph or the next paragraph, and such backup material shall be interpreted as though such language does not exist.

AS TO THE SCOPE OF THIS CHANGE ORDER, CONTRACTOR EXPRESSLY UNDERSTANDS AND AGREES TO WAIVE THE PROVISIONS OF, AND ALL RIGHTS AND BENEFITS AFFORDED BY, CALIFORNIA CIVIL CODE SECTION 1542, WHICH PROVIDES IN FULL AS FOLLOWS:

A GENERAL RELEASE DOES NOT EXTEND TO CLAIMS THAT THE CREDITOR OR RELEASING PARTY DOES NOT KNOW OR SUSPECT TO EXIST IN HIS OR HER FAVOR AT THE TIME OF EXECUTING THE RELEASE, AND THAT, IF KNOWN BY HIM OR HER, WOULD HAVE MATERIALLY AFFECTED HIS OR HER SETTLEMENT WITH THE DEBTOR OR RELEASED PARTY.

This Change Order is hereby agreed to, accepted, and approved, and will be binding and enforceable upon signature by Contractor and approval by the Owner's governing body.

OAKLAND UNIFIED SCHOOL DISTRICT

Division of Facilities Planning and Management • 955 High Street Oakland, California 94601 • Phone 510/535-2728

Approved: Architect of Record Print Name: Susannah Meek Signature:  Date: 9/26/2024 Approved as to Form: <i>James Traber</i> OUSD Facilities Counsel Date: 11/27/2024	Approved and Agreed: General Contractor Print Name: Robert Arntz Signature:  Date: 09/30/2024	Approved and Agreed:  Executive Director, Facilities Date: 10/10/2024  Chief Systems & Services Officer, Facilities Date: 11/21/24
---	---	---

Name: Jennifer Brouhard
Title: President, Board of Education

Sign:  Date: 1/9/2025

Name: Kyla Johnson-Trammell
Title: Superintendent & Secretary, Board of Education

Sign:  Date: 1/9/2025

Digitally signed by Olakunle Gbadamosi
DN: C=US,
E=ogbadamosi@bdcconnect.com,
O="Ballston & Dunlavy, Inc.",
CN=Olakunle Gbadamosi
Reason: I am approving this document
Date: 2024.09.30 21:15:09-0700

Olakunle Gbadamosi

OAKLAND UNIFIED SCHOOL DISTRICT

Division of Facilities Planning and Management • 955 High Street Oakland, California 94601 • Phone 510/535-2728 • Fax 510/535-7040

(Proposed Change Order) No. 1

PROJECT: Claremont Middle School MPR & Kitchen Project

DATE: OCTOBER 30, 2024

DSA FILE NO.: 01-119337

OWNER: OAKLAND UNIFIED SCHOOL DISTRICT

DSA APP NO.: 01-119337

CONTRACTOR: ARNTZ BUILDERS INC.

OUSD PROJECT #: 15127

431 Payran

PROJECT MANAGER: JaQuan Cornish

Petaluma, CA 94952

Contractor hereby submits this Change Order Request ("COR") pursuant to the contract documents, including but not limited to General Conditions sections 4.5.1, 4.5.2, 7.6, 7.7, 8.4.1, and 8.4.2.

DESCRIPTION OF PROPOSED CHANGES IN WORK (specifically refer to attached pages or incorporated documents): **PCO 27 – Face of Stage Finish (Error):** There was no call out for what the actual finish material. AOR's RFI response specified a furred gyp wall. The face of the gyp board was installed flush with adjacent wall.

OTHER PROPOSED CHANGES TO THE CONTRACT:

PCOs: #58, #75, #97, #120, #128, #139, #143, #144 & #146

PROPOSED ADJUSTMENT TO CONTRACT PRICE: **\$2,153.35**

PROPOSED ADJUSTMENT TO CONTRACT TIME: 0 calendar days

REASON FOR REQUEST (check one or more):

- Unforeseen Conditions
- Direction by Government Agency
- Owner Requested
- Design Omission
- Design Error
- Other: _____

OAKLAND UNIFIED SCHOOL DISTRICT

Division of Facilities Planning and Management • 955 High Street Oakland, California 94601 • Phone 510/535-2728 • Fax 510/535-7040

CERTIFICATION

I, Robert Arntz [name of declarant], declare the following:

Arntz Builders Inc. [Contractor company name] has contracted with Oakland Unified School District [public entity name] for the Claremont Middle School MPR & Kitchen Contract ("Contract"). Arntz Builders Inc. [Contractor company name] authorized me to prepare the attached Change Order Request ("COR") for money and/or time extension for Oakland Unified School District [public entity name] regarding this Contract (such COR being dated October 30, 2024, and entitled Change Order 1 and requesting \$2,153.35 and/or 0 additional days), and I prepared the attached COR. I am the most knowledgeable person at Arntz Builders Inc. [Contractor company name] regarding this COR.

The attached COR complies with all laws applicable to submission of a COR, including but not limited to California Penal Code section 72, Government Code sections 12650 et seq. (False Claims Act), and Business and Professions Code sections 17200 et seq. (Unfair Business Practices Act). I am aware that submission or certification of false claims, or other claims that violate law or the Contract, may lead to fines, imprisonment, and/or other serious legal consequences for myself or Arntz Builders [Contractor company name].

The attached COR does not breach the Contract, is not a false claim, does not violate any applicable law, satisfies all provisions of the Contract applicable to submission of the COR, only contains truthful and accurate supporting data, and only requests money and/or time extensions that accurately reflect the adjustments to money and time for which I believe that Oakland Unified School District [public entity name] is responsible under its Contract with Arntz Builders Inc. [Contractor company name].

While preparing this declaration and COR I consulted with others (including attorneys, consultants, or others who work for Arntz Builders Inc. [Contractor company name]) when necessary to ensure that the statements were true and correct.

Contractor understands and agrees that any COR submitted without this certification does not meet the terms of the Contract Documents; that Owner, or Owner's representatives, may reject the COR on that basis; and that unless Contractor properly and timely files the COR with the certification, Contractor cannot further pursue the COR in any forum and all rights to additional money or time for the issues covered by the COR are waived due to a condition precedent not having been satisfied.

I declare under the penalty of perjury under the laws of the State of California that the foregoing is true and correct. Executed October 30, 2024, at Oakland, California.

 [signature]

Robert Arntz [name of declarant]



Arntz Builders, Inc.

431 Payran St, Petaluma CA 94952 License No. 856393 T (707) 835-2900 F (707) 835-2993 www.arntzbuilders.com

Date: 11/14/22

Project Name: 2205 Claremont MS MPR & Kitchen

Generating Document: RFI 94

Arntz File #: 027

Arntz File Title: Face of Stage Finish

NOTIFICATION OF EXTRA:

The above referenced issue constitutes a changed condition resulting in extra work and extra costs. This condition will impact the project schedule.

Scope Change: There was no call out on the contract drawings of what the face of stage finish was. RFI response includes sketch ASK-18, which gives clarification on what the finish is to be.

Location: MPR Stage



Arntz Builders, Inc.

431 Payran St, Petaluma CA 94952 License No. 856393 T (707) 835-2900 F (707) 835-2993 www.amtzbuilders.com

July 11, 2024

Oakland Unified School District
1000 Broadway, Ste 300
Oakland, CA 94607

Subject : Claremont MS New Multi-Purpose and Kitchen
File No. 27.1 Face of Stage Finish

Good Afternoon,

There was no call out on the contract drawings of what the face of stage finish was. RFI response includes sketch ASK-18, which gives clarification on what the finish is to be.

Prime Work:

Labor		\$556.00
Material		\$723.00
Equipment/Other		\$0.00
Prime Subtotal		\$1,279.00
Mark-Up	15.0%	\$191.85
Prime Total		\$1,470.85

Subcontractor Work:

Hartley Construction		\$650.00
Subcontractor Subtotal		\$650.00
Mark-Up	5.00%	\$32.50
Total Subcontractor Quotation		\$682.50

TOTAL PRIME & SUBCONTRACTOR QUOTATION \$2,153.35

We reserve the right to submit a claim for an extension of time and for all related delay and inefficiency costs that may result due to the changed condition. The extent and amount will be determined at a later date when the full impact of changed condition can be evaluated and determined. All rights and remedies are reserved.

Sincerely,

ARNTZ BUILDERS

Robert Arntz
Project Manager

cc:
ST
enc

Hartley Construction

**Claremont Middle School
RFI# 94**

ITEM	QTY	unit	Materials		Labor		Equipment	
			UNIT	MAT.	UNIT	LABOR	UNIT	EQUIP.
Plaster Installation	6	hrs	0.00	0.00	83.09	498.54	0.00	0.00
Set up/Clean up	0.5	hrs	0.00	0.00	83.09	41.55	0.00	0.00
Plaster Adhesive	1	can	26.75	26.75	0.00	0.00	0.00	0.00
Plaster Finish Coat	3	bags	24.25	72.75	0.00	0.00	0.00	0.00
			0.00	0.00	0.00	0.00	0.00	0.00
			0.00	0.00	0.00	0.00	0.00	0.00
Subtotals:			Materials:	99.50	Labor:	540.09	Equip.:	0.00

Material Summary

Material Cost (See Estimate Sheet Above.)	\$100
Misc. Materials 2%	
Subtotal Materials	\$100
+ 10.25% Sales Tax	\$10
TOTAL MATERIALS	\$110

Labor Summary

Labor (See Estimate Sheet Above.)	\$540
Subtotal Labor	\$540
Safety (4% x Labor)	
TOTAL LABOR	\$540

Other Direct Cost

Tool/Equipment Rental (See Estimate Sheet Above.)	\$0
Dump Charges	\$0
Detailing/As Builts	\$0
Estimating	\$0
Construction Schedule Updating	\$0
Blueprinting/copying	\$0
Subcontract Preparation fee	\$0
Project Manager	\$0
TOTAL OTHER DIRECT COSTS	\$0

SUBTOTAL COSTS: \$650

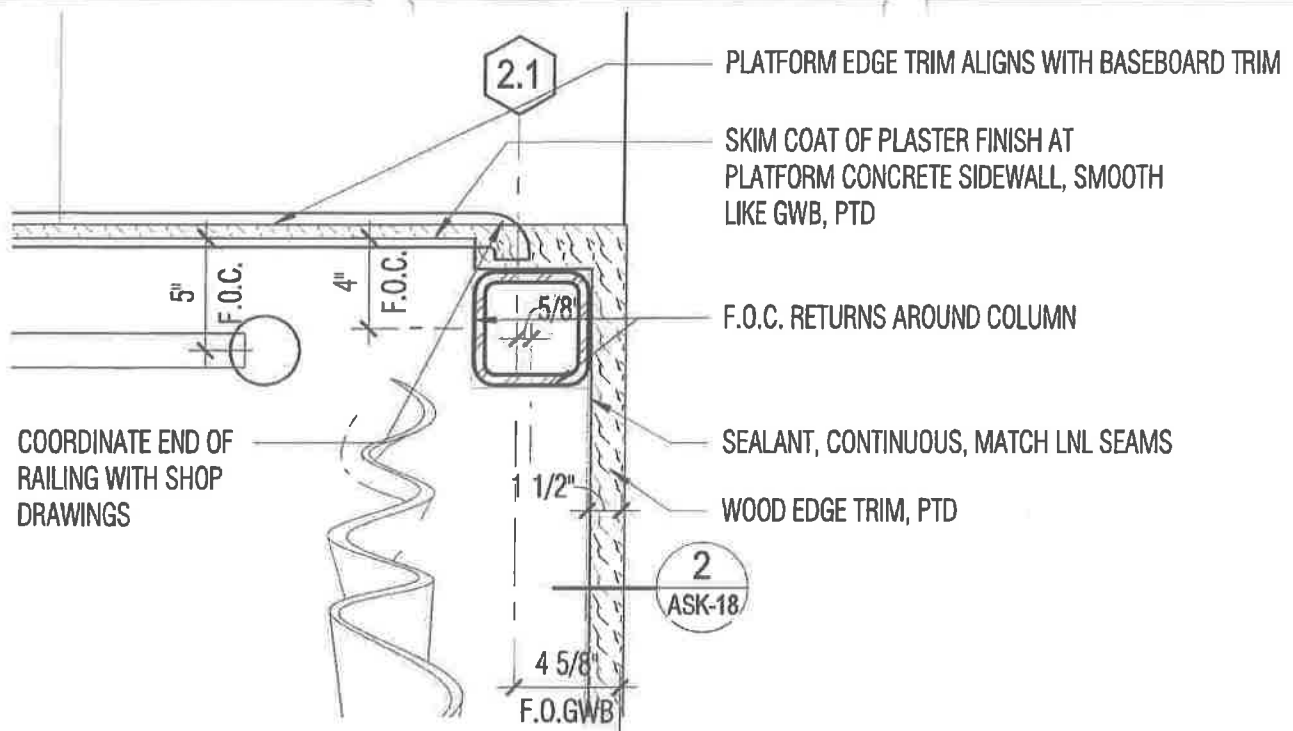

1 INTERIOR RAMP CORNER
 ASK-18 1 1/2" = 1'-0"

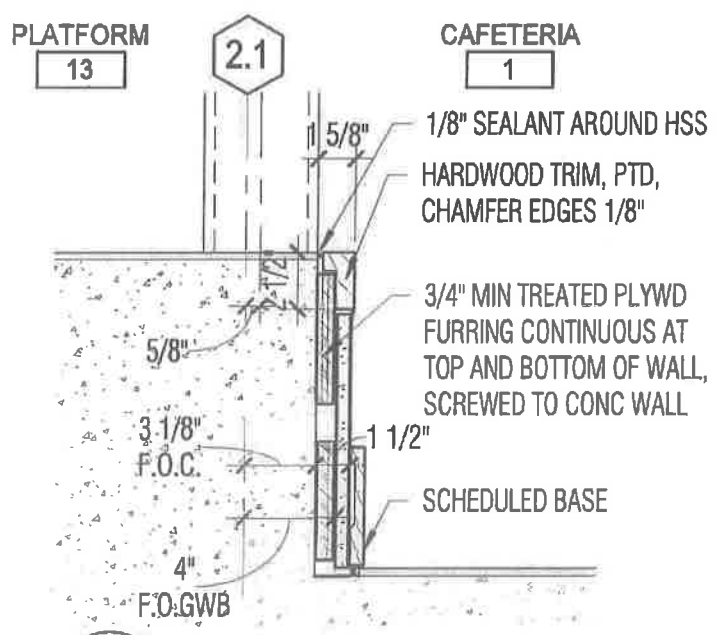

2 PLATFORM EDGE FINISH
 ASK-18 1 1/2" = 1'-0"

S MEEK Architecture
 3040 24th Street
 San Francisco CA 94110
 tel 415-543-5505



OAKLAND UNIFIED SCHOOL DISTRICT
CLAREMONT MIDDLE SCHOOL
MULTI-PURPOSE BUILDING & KITCHEN
 5750 College Ave Oakland CA 94618

DSA APP # 01-119337
 OUSD Project #15127

DATE: 11/1/2022
 SCALE: 1 1/2" = 1'-0"
 ISSUED BY: RFI 94
 DRAWING |A2.09, 3/A7.31
 SKETCH #:

ASK-18



**S MEEK
ARCHITECTURE**

3640 94th Street
San Francisco, CA 94110
415-608-8025



**CLAREMONT
MIDDLE
SCHOOL**
8750 College Ave
Oakland, CA 94618

**Multi-Purpose
Building &
Kitchen**

Oakland
Unified
School
District

Name: Solt / Proffers
No. Description
Date
7/17/20
7/17/20
8/23/20
1/11/20
2/22/20
2/22/20
1/15/21

Subcontract Design
Design Development
Schematic Design
Schematic Design
Schematic Design
Schematic Design
Schematic Design

A5.01
Interior Elevations
1/15/2021
19327
CLOSED JOB NO.

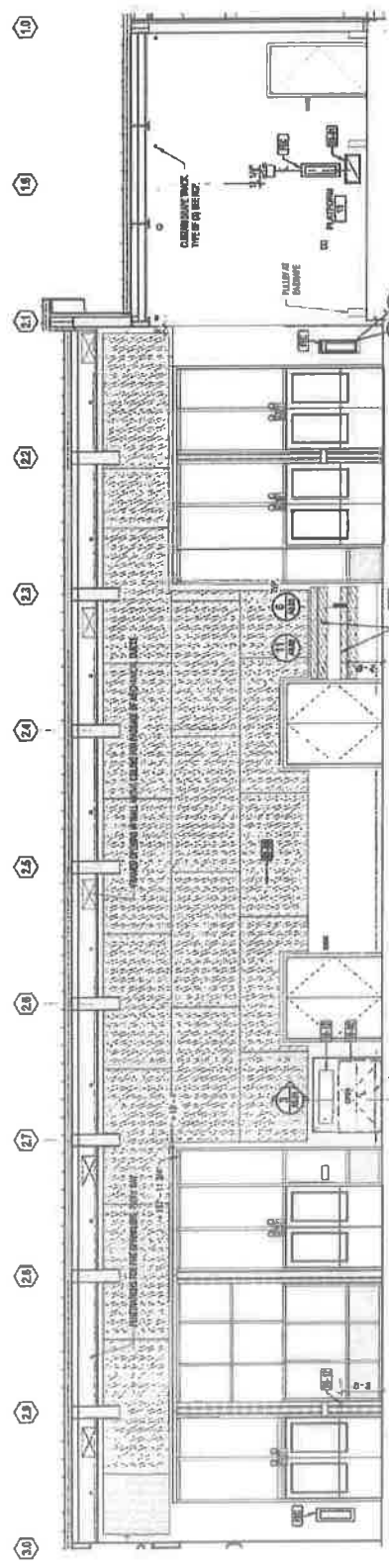

NETWORKS LAYOUT

Room #	Equipment Type
24-21	WOOD BENT BRACKET FOR HANGING AND PANEL
24-22	WOOD BENT BRACKET FOR HANGING AND PANEL
24-23	WOOD BENT BRACKET FOR HANGING AND PANEL
24-24	WOOD BENT BRACKET FOR HANGING AND PANEL
24-25	WOOD BENT BRACKET FOR HANGING AND PANEL
24-26	WOOD BENT BRACKET FOR HANGING AND PANEL
24-27	WOOD BENT BRACKET FOR HANGING AND PANEL
24-28	WOOD BENT BRACKET FOR HANGING AND PANEL
24-29	WOOD BENT BRACKET FOR HANGING AND PANEL
24-30	WOOD BENT BRACKET FOR HANGING AND PANEL
24-31	WOOD BENT BRACKET FOR HANGING AND PANEL
24-32	WOOD BENT BRACKET FOR HANGING AND PANEL
24-33	WOOD BENT BRACKET FOR HANGING AND PANEL
24-34	WOOD BENT BRACKET FOR HANGING AND PANEL
24-35	WOOD BENT BRACKET FOR HANGING AND PANEL
24-36	WOOD BENT BRACKET FOR HANGING AND PANEL
24-37	WOOD BENT BRACKET FOR HANGING AND PANEL
24-38	WOOD BENT BRACKET FOR HANGING AND PANEL
24-39	WOOD BENT BRACKET FOR HANGING AND PANEL
24-40	WOOD BENT BRACKET FOR HANGING AND PANEL
24-41	WOOD BENT BRACKET FOR HANGING AND PANEL
24-42	WOOD BENT BRACKET FOR HANGING AND PANEL
24-43	WOOD BENT BRACKET FOR HANGING AND PANEL
24-44	WOOD BENT BRACKET FOR HANGING AND PANEL
24-45	WOOD BENT BRACKET FOR HANGING AND PANEL
24-46	WOOD BENT BRACKET FOR HANGING AND PANEL
24-47	WOOD BENT BRACKET FOR HANGING AND PANEL
24-48	WOOD BENT BRACKET FOR HANGING AND PANEL
24-49	WOOD BENT BRACKET FOR HANGING AND PANEL
24-50	WOOD BENT BRACKET FOR HANGING AND PANEL
24-51	WOOD BENT BRACKET FOR HANGING AND PANEL
24-52	WOOD BENT BRACKET FOR HANGING AND PANEL
24-53	WOOD BENT BRACKET FOR HANGING AND PANEL
24-54	WOOD BENT BRACKET FOR HANGING AND PANEL
24-55	WOOD BENT BRACKET FOR HANGING AND PANEL
24-56	WOOD BENT BRACKET FOR HANGING AND PANEL
24-57	WOOD BENT BRACKET FOR HANGING AND PANEL
24-58	WOOD BENT BRACKET FOR HANGING AND PANEL
24-59	WOOD BENT BRACKET FOR HANGING AND PANEL
24-60	WOOD BENT BRACKET FOR HANGING AND PANEL
24-61	WOOD BENT BRACKET FOR HANGING AND PANEL
24-62	WOOD BENT BRACKET FOR HANGING AND PANEL
24-63	WOOD BENT BRACKET FOR HANGING AND PANEL
24-64	WOOD BENT BRACKET FOR HANGING AND PANEL
24-65	WOOD BENT BRACKET FOR HANGING AND PANEL
24-66	WOOD BENT BRACKET FOR HANGING AND PANEL
24-67	WOOD BENT BRACKET FOR HANGING AND PANEL
24-68	WOOD BENT BRACKET FOR HANGING AND PANEL
24-69	WOOD BENT BRACKET FOR HANGING AND PANEL
24-70	WOOD BENT BRACKET FOR HANGING AND PANEL
24-71	WOOD BENT BRACKET FOR HANGING AND PANEL
24-72	WOOD BENT BRACKET FOR HANGING AND PANEL
24-73	WOOD BENT BRACKET FOR HANGING AND PANEL
24-74	WOOD BENT BRACKET FOR HANGING AND PANEL
24-75	WOOD BENT BRACKET FOR HANGING AND PANEL
24-76	WOOD BENT BRACKET FOR HANGING AND PANEL
24-77	WOOD BENT BRACKET FOR HANGING AND PANEL
24-78	WOOD BENT BRACKET FOR HANGING AND PANEL
24-79	WOOD BENT BRACKET FOR HANGING AND PANEL
24-80	WOOD BENT BRACKET FOR HANGING AND PANEL
24-81	WOOD BENT BRACKET FOR HANGING AND PANEL
24-82	WOOD BENT BRACKET FOR HANGING AND PANEL
24-83	WOOD BENT BRACKET FOR HANGING AND PANEL
24-84	WOOD BENT BRACKET FOR HANGING AND PANEL
24-85	WOOD BENT BRACKET FOR HANGING AND PANEL
24-86	WOOD BENT BRACKET FOR HANGING AND PANEL
24-87	WOOD BENT BRACKET FOR HANGING AND PANEL
24-88	WOOD BENT BRACKET FOR HANGING AND PANEL
24-89	WOOD BENT BRACKET FOR HANGING AND PANEL
24-90	WOOD BENT BRACKET FOR HANGING AND PANEL
24-91	WOOD BENT BRACKET FOR HANGING AND PANEL
24-92	WOOD BENT BRACKET FOR HANGING AND PANEL
24-93	WOOD BENT BRACKET FOR HANGING AND PANEL
24-94	WOOD BENT BRACKET FOR HANGING AND PANEL
24-95	WOOD BENT BRACKET FOR HANGING AND PANEL
24-96	WOOD BENT BRACKET FOR HANGING AND PANEL
24-97	WOOD BENT BRACKET FOR HANGING AND PANEL
24-98	WOOD BENT BRACKET FOR HANGING AND PANEL
24-99	WOOD BENT BRACKET FOR HANGING AND PANEL
24-100	WOOD BENT BRACKET FOR HANGING AND PANEL

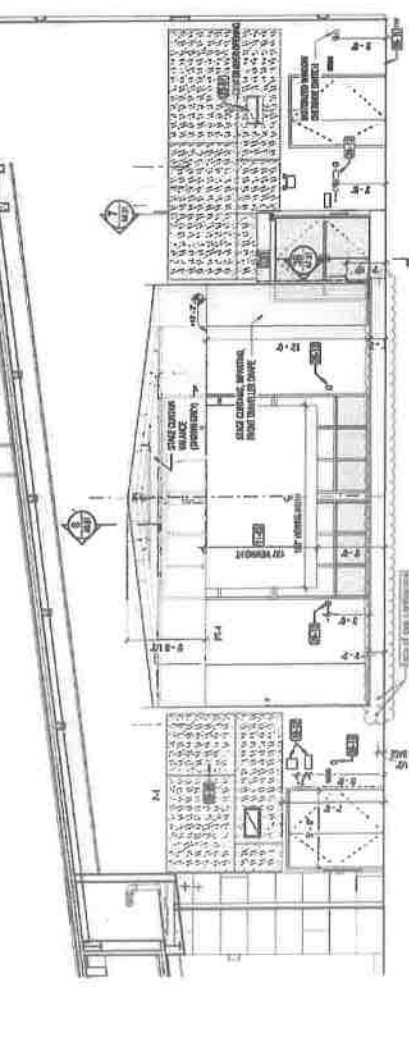
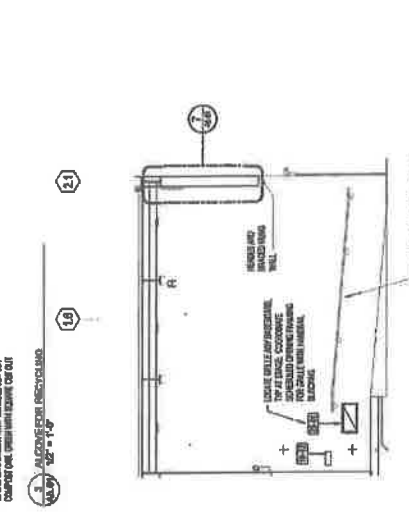
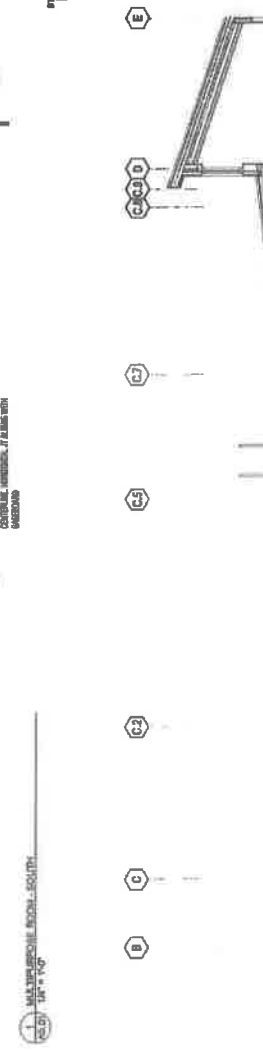

3.0 MULTI-PURPOSE ROOM - SOUTH
1/15/21

4.0 MULTI-PURPOSE ROOM - WEST
1/15/21

OAKLAND UNIFIED SCHOOL DISTRICT
CLAREMONT MS MULTI-PUROSE & KITCHEN BUILDING
PROJ # 15127
CCR#27.1 ABI FILE 27 - FACE OF STAGE FINISH

To: M. TORRES/CM; C. HENDERSON/PE
From: Emil Vinuya, PE/Chief Cost Estimator
Date: 1-Aug-24

General Comments:

1 GENERAL CONTRACTOR: ARNTZ BUILDERS, INC.

Cost proposed by GC appears reasonable.

2 SUBCONTRACTOR: HARTLEY

Cost proposed by Sub appears reasonable.

3 GENERAL CONTRACTOR's COST PROPOSALS

\$ 2,153.35

ESTIMATED CONSTRUCTION COST FOR CCR#027.1

\$ 2,153.35

Detailed Estimate

CLAREMONT MS MULTI-PURPOSE & KITCHEN BUILDING											
										Date: 8/6/24	
No.	CCR#27.1	No. of Units	Per	M.H. Per Unit	M. H. Total	LABOR COST		MATERIAL COST		EQUIPT. COST	
						Cost Per M. H.	Total Cost	Unit Cost	Total Cost	Unit Cost	Total Cost
GEN CONTRACTOR		ARTZ BUILDERS INC.									
Project Description:		ABI FILE 27 - FACE OF STAGE FINISH									
1	SCOPE OF WORK:										
2	Clarification of Stage Finish	1	LS								
3											
4	MATERIALS										
5	PT plywood Furring	1	LS	\$ 4.000	4.00			\$ 211.00	\$ 211.00		
6	Hardwood Trim	1	LS	\$ 4.550	4.55			\$ 535.00	\$ 535.00		
7	Misc. Materials	1	LS	\$ -	0.00			\$ 28.90	\$ 28.90		
8	Credit for Metal Stud	-80	LF	\$ 0.050	-4.00			\$ 1.25	\$ (100.00)		
9					4.55						
10	LABOR:										
11	Carpenter/JM	1.00	EA	8.55	8.55	\$ 100.00	\$ 855				
12	Carpenter/JM	1.00	EA	-4.00	-4.00	\$ 80.00	\$ (320)				
13											
14					4.55						
15											
16	EQUIPMENT										
17	Not Used	0.00	EA							\$ -	
18										\$ -	
19											
20											
21	SHEET TOTALS						\$535.00	\$ 674.90		\$ -	

Detailed Estimate

CLAREMONT MS MULTI-PURPOSE & KITCHEN BUILDING										
										Date: #REF!
No.	CCR#27.1	LABOR COST					MATERIAL COST		EQUIPT. COST	
		No. of Units	Per	M.H. Per Unit	M. H. Total	Cost Per M. H.	Total Cost	Unit Cost	Total Cost	Unit Cost
GEN CONTRACTOR		HARTLEY								
Project Description:		ABI FILE 27 - FACE OF STAGE FINISH								
1	SCOPE OF WORK:									
2	Plaster	1	LS							
3										
4	MATERIALS									
5	Plaster Materials	1	LS	\$ -	0.00			\$ 100.00	\$ 100.00	
6										
7										
8										
9	LABOR:									
10	Plasterer	1.00	EA	6.00	6.00	\$ 83.09	\$ 498.54			
11	Clean/Up	1.00	EA	0.50	0.50	\$ 83.09	\$ 41.55			
12										
13					6.50					
14										
15	EQUIPMENT									
16	Not Used	0.00	EA						\$ -	\$ -
17										
18										
19										
20	SHEET TOTALS						\$540.09	\$ 100.00		\$ -

OAKLAND UNIFIED SCHOOL DISTRICT

Division of Facilities Planning and Management • 955 High Street Oakland, California 94601 • Phone 510/535-2728 • Fax 510/535-7040

(Proposed Change Order) No. 2

PROJECT: Claremont Middle School MPR & Kitchen Project

DATE: OCTOBER 30, 2024

OWNER: OAKLAND UNIFIED SCHOOL DISTRICT

DSA FILE NO.: 01-119337

CONTRACTOR: ARNTZ BUILDERS INC.

DSA APP NO.: 01-119337

431 Payran

OUSD PROJECT #: 15127

Petaluma, CA 94952

PROJECT MANAGER: JaQuan Cornish

Contractor hereby submits this Change Order Request ("COR") pursuant to the contract documents, including but not limited to General Conditions sections 4.5.1, 4.5.2, 7.6, 7.7, 8.4.1, and 8.4.2.

DESCRIPTION OF PROPOSED CHANGES IN WORK (specifically refer to attached pages or incorporated documents): **PCO 58 – Extended General Conditions (Unforeseen):** Arntz submitted a Time Impact Analysis identifying the delays and number of days. The analysis was reviewed and approved by the district.

OTHER PROPOSED CHANGES TO THE CONTRACT:

PCOs: #27, #75, #97, #120, #128, #139, #143, #144 & #146

PROPOSED ADJUSTMENT TO CONTRACT PRICE: \$0

PROPOSED ADJUSTMENT TO CONTRACT TIME: 48 calendar days

REASON FOR REQUEST (check one or more):

- Unforeseen Conditions
- Direction by Government Agency
- Owner Requested
- Design Omission
- Design Error
- Other: _____

OAKLAND UNIFIED SCHOOL DISTRICT

Division of Facilities Planning and Management • 955 High Street Oakland, California 94601 • Phone 510/535-2728 • Fax 510/535-7040

CERTIFICATION

I, Robert Arntz [name of declarant], declare the following:

Arntz Builders Inc. [Contractor company name] has contracted with Oakland Unified School District [public entity name] for the Claremont Middle School MPR & Kitchen Contract ("Contract"). Arntz Builders Inc. [Contractor company name] authorized me to prepare the attached Change Order Request ("COR") for money and/or time extension for Oakland Unified School District [public entity name] regarding this Contract (such COR being dated October 30, 2024, and entitled Change Order 1 and requesting \$2,153.35 and/or 0 additional days), and I prepared the attached COR. I am the most knowledgeable person at Arntz Builders Inc. [Contractor company name] regarding this COR.

The attached COR complies with all laws applicable to submission of a COR, including but not limited to California Penal Code section 72, Government Code sections 12650 et seq. (False Claims Act), and Business and Professions Code sections 17200 et seq. (Unfair Business Practices Act). I am aware that submission or certification of false claims, or other claims that violate law or the Contract, may lead to fines, imprisonment, and/or other serious legal consequences for myself or Arntz Builders [Contractor company name].

The attached COR does not breach the Contract, is not a false claim, does not violate any applicable law, satisfies all provisions of the Contract applicable to submission of the COR, only contains truthful and accurate supporting data, and only requests money and/or time extensions that accurately reflect the adjustments to money and time for which I believe that Oakland Unified School District [public entity name] is responsible under its Contract with Arntz Builders Inc. [Contractor company name].

While preparing this declaration and COR I consulted with others (including attorneys, consultants, or others who work for Arntz Builders Inc. [Contractor company name]) when necessary to ensure that the statements were true and correct.

Contractor understands and agrees that any COR submitted without this certification does not meet the terms of the Contract Documents; that Owner, or Owner's representatives, may reject the COR on that basis; and that unless Contractor properly and timely files the COR with the certification, Contractor cannot further pursue the COR in any forum and all rights to additional money or time for the issues covered by the COR are waived due to a condition precedent not having been satisfied.

I declare under the penalty of perjury under the laws of the State of California that the foregoing is true and correct. Executed October 30, 2024, at Oakland, California.

 [signature]

Robert Arntz [name of declarant]

OAKLAND UNIFIED SCHOOL DISTRICT

Division of Facilities Planning and Management • 955 High Street Oakland, California 94601 • Phone 510/535-2728 • Fax 510/535-7040

ALLOWANCE EXPENDITURE DIRECTIVE NO. 78 For the Measure Y ALLOWANCE

PROJECT: Claremont Multi-Purpose Building & Kitchen
Claremont Middle School

DATE: JANUARY 23, 2024
DSA FILE NO.: 01-119337
DSA APP NO.: 01-119337
OUSD PROJECT #: 15127
PROJECT MANAGER: Mike Torres

OWNER: OAKLAND UNIFIED SCHOOL DISTRICT
CONTRACTOR: ARNTZ BUILDERS INC.

If not previously directed, the Contractor is hereby directed to perform the Work described in this allowance expenditure directive and its attachments, including but not limited to the Summary, the relevant CORs or PCOs, and the backup documentation for the CORs or PCOs. **Any request for a time extension for such work must be separately processed** via contract procedures and a change order.

DESCRIPTION OF AGREED CHANGES IN LLB WORK (specifically refer to attached pages or incorporated documents, such as CORs or PCOs, or include a detailed description of the changes):

PCO 58 – Extended General Conditions (Unforeseen): Cost associated with extended general conditions. Arntz Time Impact Analysis was submitted for review and approved.

AGREED ALLOWANCE EXPENDITURE FOR THIS LLB WORK: \$160,610

SUMMARY OF ADJUSTMENTS TO LLB ALLOWANCE:

Original Amount of Allowance:	\$ 1,300,000.00
Board-Approved Changes to Allowance:	\$ 0
Previous Allowance Expenditure Directives:	\$ 784,442.65
This Allowance Expenditure Directive:	\$ 160,610
Remaining Amount of Allowance:	\$ 354,947.35

THE COMPENSATION SET FORTH IN THIS DIRECTIVE COMPRISES THE TOTAL COMPENSATION DUE THE CONTRACTOR UPON COMPLETION OF THE WORK DESCRIBED, INCLUDING EXTRA WORK, AND IMPACT ON UNCHANGED WORK. ACCEPTANCE BY CONTRACTOR OF THIS DIRECTIVE CONSTITUTES A FULL AND COMPLETE ACCORD AND SATISFACTION OF ANY AND ALL CLAIMS BY CONTRACTOR ARISING OUT OF OR RELATING TO THE WORK AND ISSUES COVERED BY THE DIRECTIVE, INCLUDING BUT NOT LIMITED TO CLAIMS FOR CONTRACT BALANCE AND RETENTION, EXTENDED FIELD, HOME OFFICE OR OTHER OVERHEAD, ALL ACCELERATION, IMPACT, DISRUPTION AND DELAY DAMAGES, ANY AND ALL OTHER DIRECT AND/OR INDIRECT COSTS, CLAIMS BY SUBCONTRACTORS AND SUPPLIERS, AND ANY AND ALL OTHER CLAIMS AGAINST THE OWNER FOR MONEY, FROM ANY SOURCE AND UNDER ANY LEGAL THEORY WHATSOEVER, AS TO THE SUBJECT OF THIS DIRECTIVE. NO SIGNATURE UNDER PROTEST OR ACCOMPANIED BY RESERVATION OF RIGHTS OR PROTEST LANGUAGE, OR ANY OTHER ATTEMPTS TO AVOID SUCH WAIVER SHALL BE OF ANY FORCE OR EFFECT WHATSOEVER. NO ADDITIONS OR DELETIONS TO THIS DIRECTIVE SHALL BE ALLOWED, EXCEPT WITH WRITTEN PERMISSION OF OWNER. NO LANGUAGE CONTAINED IN BACKUP MATERIAL TO THIS DIRECTIVE SHALL CONSTITUTE A WAIVER OF THIS REQUIREMENT, AND SUCH BACKUP MATERIAL SHALL BE INTERPRETED AS THOUGH SUCH LANGUAGE DOES NOT EXIST.

AS TO THE SCOPE OF THIS DIRECTIVE, CONTRACTOR EXPRESSLY UNDERSTANDS AND AGREES TO WAIVE THE PROVISIONS OF, AND ALL RIGHTS AND BENEFITS AFFORDED BY, CALIFORNIA CIVIL CODE SECTION 1542, WHICH PROVIDES IN FULL AS FOLLOWS:



Arntz Builders, Inc.

431 Payran St, Petaluma CA 94952 License No. 856393 T (707) 835-2900 F (707) 835-2993 www.arntzbuilders.com

Date: 4/24/23

Project Name: 2205 Claremont MS MPR & Kitchen

Generating Document: Time Impact Analysis 01

Arntz File #: 058

Arntz File Title: Extended General Conditions

NOTIFICATION OF EXTRA:

The above referenced issue constitutes a changed condition resulting in extra work and extra costs. This condition will impact the project schedule.

Scope Change: Costs associated with extended general conditions.

Location: Site



Arntz Builders, Inc.

431 Payran St, Petaluma CA 94952 License No. 856393 T (707) 835-2900 F (707) 835-2993 www.arntzbuilders.com

April 27, 2023

Oakland Unified School District

1000 Broadway, Ste 300
Oakland, CA 94607

Subject Claremont MS New Multi-Purpose and Kitchen
File No. . . . 58 Extended General Conditions

Extended General Conditions 8/3/23 through 9/20/23. Based on TIA 01.

Prime Work:

Labor		\$160,610.00
Material		\$0.00
Equipment/Other		\$0.00
Prime Subtotal		<u>\$160,610.00</u>
Mark-Up	15.0%	<u>\$0.00</u>

TOTAL QUOTE **\$160,610.00**

We reserve the right to submit a claim for an extension of time and for all related delay and inefficiency costs that may result due to the changed condition. The extent and amount will be determined at a later date when the full impact of changed condition can be evaluated and determined. All rights and remedies are reserved.

Sincerely,

ARNTZ BUILDERS

Robert Arntz
Project Manager

cc:
ST
enc

REFERENCED FILES

FILES

- [Claremont MS MPR - TIAx001 - Un-impacted.mpp](#) – MSP file of the Approved Baseline “Claremont MS MPR - BLO2.mpp”. This represents the Un-Impacted schedule.
- [Claremont MS MPR - TIAx001 - Impacted.mpp](#) – MSP file of Time Impact Analysis impacted schedule.
- [Claremont - TIAx001 - Delayed Critical Path.pdf](#) – Print of the Time Impact Analysis comparing the Un-Impacted to the Impacted and Adjusted Delay schedules critical path in detail.
- [Claremont - TIAx001 - Delay Activities.pdf](#) – Print of the Time Impact Analysis comparing the Un-Impacted to the Impacted and Adjusted Delay schedules critical path showing detail for activities occurring close to the affected activity as well as the final completion milestone.

Impact Table

Table 1.2 compares the "Pre Impact Schedule" and the "Post TIE Impact Schedule" to calculate the overall delay to the project schedule.

Window 01 (7/7/2022 – 10/17/2022)		
Description	Pre Impact	Post TIE Impact
Schedule	Claremont MS MPR As-Plan R1.mpp	Claremont MS MPR - TIAx001 - Impacted.mpp
Data Date	26-May-22	26-May-22
Completion	3-Aug-23	10-Oct-23
Mitigation		0
Delay		68
TOTAL		68

Table 1.2

Table 1.2 represents the delay time period. This window includes information from the issues as was discussed above. The analysis shows the completion date of the schedule slipped from the 3rd of August, 2023 to the 10th of October, 2023. This is a 68 calendar day delay.

This analysis was compared against the schedule updates to determine the actual effect of the delay on the project. Below is a table of the update history through January 2023.

Schedule	Data Date	Contract Completion	Scheduled Completion	Change	TOTAL DELAY
BL	5/26/2022	8/3/2023	8/3/2023		
U01	8/1/2022	8/3/2023	10/6/2023	64	-64
U02	9/1/2022	8/3/2023	8/3/2023	-64	0
U03	10/1/2022	8/3/2023	10/12/2023	70	-70
U03R*	10/1/2022	8/3/2023	9/20/2023	-22	-48
U04	11/1/2022	8/3/2023	9/20/2023	0	-48
U05	12/1/2022	8/3/2023	9/20/2023	0	-48
U06	1/1/2023	8/3/2023	9/18/2023	-2	-46
U07	2/1/2023	8/3/2023	9/25/2023	7	-53

As can be seen in the table the completion date bounces around until it stays fairly constant at the 20th of September, 2023 (48 calendar days of delay). Update 3 had a schedule revision that re-sequenced work in order to mitigate the delays. Based on the update history, Arntz was able to reduce the delay by 20 days in the re-sequencing of update U03R to 48 days. When U03R was issued, it was discussed with the CM that this was representing a best-case scenario and inefficiencies may be a result from re-sequencing tasks and stacking trades. The project experienced extra delay in January due to weather. This will be analyzed in a subsequent TIA.

DELAY DESCRIPTIONS

1. ISSUE 01

As the structural steel subcontractor began development of the structural steel submittal it was identified the specified dimensions of steel was not available. This caused a redesign of the structural steel and affected the ability to start foundation work.

METHODOLOGY

The updated Approved Baseline "Claremont MS MPR As-Plan R1.mpp" was used as the basis of the development of the Time Impact Analysis. This schedule has a scheduled completion of the 3rd of August, 2023. This schedule was used as the "Un-Impacted" schedule.

The delay activities associated with the issues were entered into the "Un-Impacted" schedule to create the "Impacted" schedule. Comparing the Un-Impacted and Impacted schedules shows the potential delay to the completion of the project. The Impacted schedule has a schedule completion of the 10th of October, 2023.

Arntz compared this against the following schedule updates to determine the experienced delay. A table showing the update history is shown in the Impact Table section of this analysis.

PROJECT OVERVIEW

VICINITY MAP

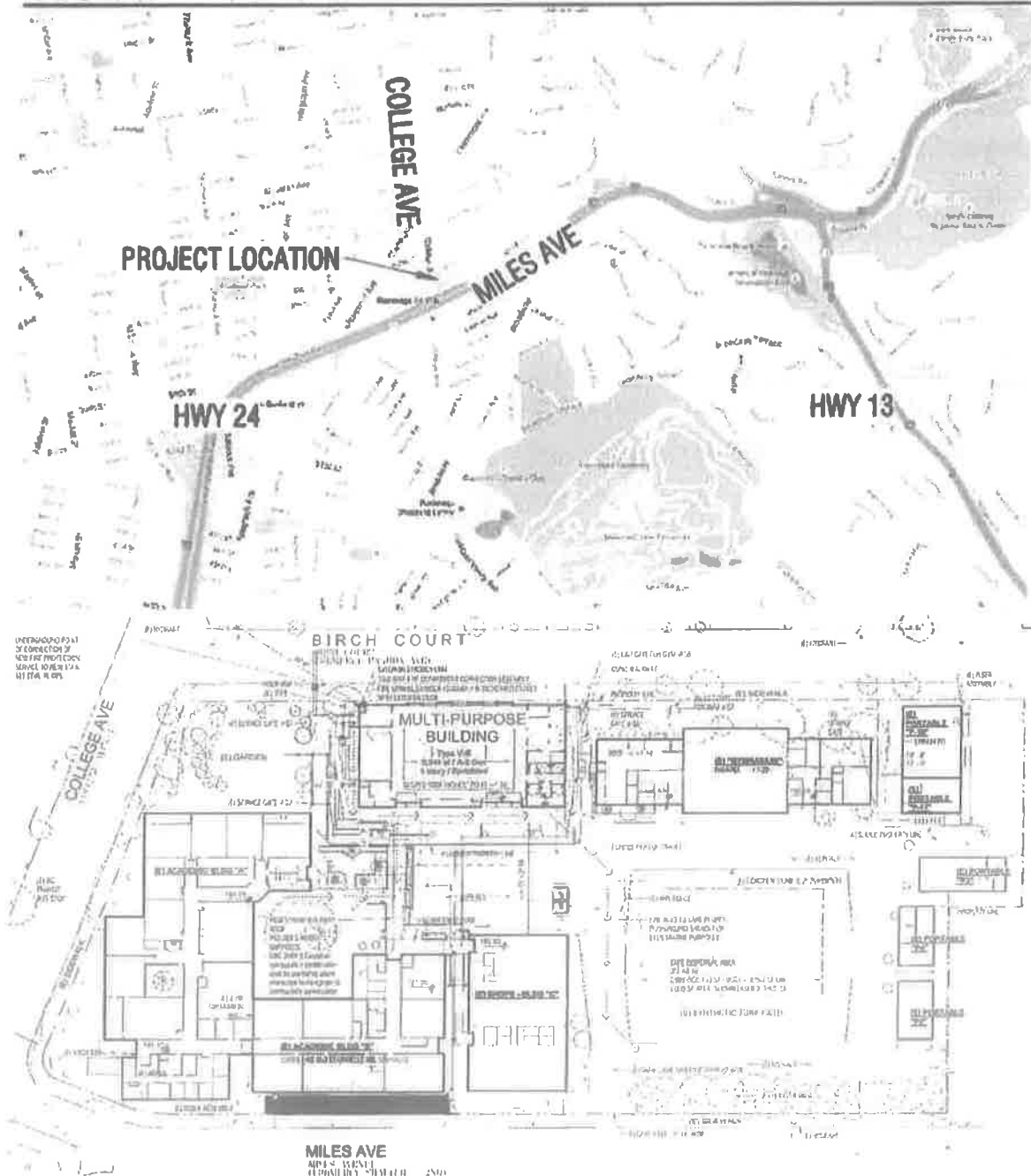

Project Description. Work covered by Contract Documents comprises selective demolition of existing site utilities, selective demolition at existing building including roofing, exterior and interior elements, interior build-out and new addition including full mechanical, electrical, plumbing, telecom and fire alarm/fire protection systems, removal and replacement of site hardscape, installation of new site utilities, fencing and gates, landscape, paving and parking striping. The project is the 2nd phase of a two-phase project.

OAKLAND UNIFIED SCHOOL DISTRICT

Time Impact Analysis x001

Claremont Middle School New Multi-Purpose Building & Kitchen

5750 College Ave
Oakland CA 94618

OSD# 15127

2/22/2023

Document Created By

Pete Hagens on behalf of Arntz Construction

OAKLAND UNIFIED SCHOOL DISTRICT
 CLAREMONT MS MULTI-PURPOSE & KITCHEN BUILDING
 PROJ # 15127
 CCCR#58 ABI FILE#058 - EXTENDED GENERAL CONDITIONS

To: M. TORRES/CM
 From: Emil Vinuya/Chief Cost Estimator
 Date: 10-Jan-24

General Comments:

1 GENERAL CONTRACTOR: ARNTZ BUILDERS, INC.

Extended Contract Duration of 48 calendars days (1.58 Mos) was based on the approved B&D Time Impact Analysis x 001 dated 2/22/2023.

Line items included in the General Conditions consistent with other current OUSD Project (Cole). Field Personnel availability as verified with the CM.

Mark-ups included by GC is 2.5% for Bond & Insurance Premium is per Contract.

General Conditions' Average monthly cost of \$101.6K for extended duration appears reasonable and is comparable to Contract's Original General Conditions per Schedule of Values.

2 GENERAL CONTRACTOR'S COST PROPOSALS **\$ 160,610**

ESTIMATED CONSTRUCTION COST FOR CCR#058 **\$ 160,610**

OAKLAND UNIFIED SCHOOL DISTRICT
 CLAREMONT MS MULTI-PURPOSE & KITCHEN BUILDING
 PROJ # 15127
 CCCR#58 ABI FILE#058 - EXTENDED GENERAL CONDITIONS

To: M. TORRES/CM
 From: Emil Vinuya/Chief Cost Estimator
 Date: 10-Jan-24

General Comments:

1 GENERAL CONTRACTOR: ARNTZ BUILDERS, INC.

Extended Contract Duration of 48 calendars days (1.58 Mos) was based on the approved B&D Time Impact Analysis x 001 dated 2/22/2023.

Line items included in the General Conditions consistent with other current OUSD Project (Cole). Field Personnel availability as verified with the CM.

Mark-ups included by GC is 2.5% for Bond & Insurance Premium is per Contract.

General Conditions' Average monthly cost of \$101.6K for extended duration appears reasonable and is comparable to Contract's Original General Conditions per Schedule of Values.

2 GENERAL CONTRACTOR's COST PROPOSALS **\$ 160,610**

ESTIMATED CONSTRUCTION COST FOR CCR#058	\$ 160,610
--	-------------------

Detailed Estimate

CLAREMONT MS MULTI-PURPOSE & KITCHEN BUILDING											
No.	CCCR#58	LABOR COST					MATERIAL COST				
		No. of Units	Per	M.H. Per Unit	M. H. Total	Cost Per M. H.	Total Cost	Unit Cost	Total Cost	Unit Cost	Total Cost
CONTRACTOR:		ARNTZ BUILDERS INC.									
Project Description:		ABI FILE#058 - EXTENDED GENERAL CONDITIONS									
1	SCOPE OF WORK:										
2	Approved Extended Duration per Time Impact Analysis#001 dated 2/22/2023	48	Cal days	0.1315	Year	1.58	Months				
3	(From 11/1/2022 thru 9/1/2023)										
4											
5											
6	General Conditions: Calculation of Project Management & Site Supervision based on SOV & General Conditions submitted & accepted by OUSD	1.58	Mos			\$160,610		\$101,651.90			
7			Cal days			\$50,000.00		\$1,100,000.00	SOV & GC Breakdown		
8											
9	Breakdown of cost for Extended GC	1.58	Mos								
10	Project management & site supervision:	1.58	Mos						Monthly Rate	Yearly Rate	
11	Senior Project Oversight/President 15%	1.58	Mos	15%		\$7,500.00	\$ 11,850.00	50,000.00	\$ 600,000.00	288.46 Reasonable	
12	Senior Project Manager, 30%	1.58	Mos	30%		\$15,000.00	\$ 23,700.00	50,000.00	\$ 600,000.00	288.46 Reasonable	
13	Superintendent, Part Time	1.58	Mos	15%		\$3,500.00	\$ 5,530.00	23,333.33	\$ 280,000.00	134.82 Reasonable	
14	Foreman	1.58	Mos	100%		\$18,100.00	\$ 28,598.00	18,100.00	\$ 217,200.00	104.42 Reasonable	
15	Project Manager, 50%	1.58	Mos	50%		\$12,000.00	\$ 18,960.00	24,000.00	\$ 288,000.00	138.46 Reasonable	
16	Project Engineer - Full time	1.58	Mos	100%		\$15,000.00	\$ 23,700.00	15,000.00	\$ 180,000.00	86.54 Reasonable	
17	Asst. PM, 70%	1.58	Mos	70%		\$10,000.00	\$ 15,800.00	14,285.71	\$ 171,428.57	82.42 Reasonable	
18	Project Accountant, 15%	1.58	Mos	15%		\$2,600.00	\$ 4,108.00	17,333.33	\$ 208,000.00	100.00 Reasonable	
19	Payroll/CPR, 15%	1.58	Mos	15%		\$2,600.00	\$ 4,108.00	17,333.33	\$ 208,000.00	100.00 Reasonable	
20	AP's/Project Costing, 15%	1.58	Mos	15%		\$2,600.00	\$ 4,108.00	17,333.33	\$ 208,000.00	100.00 Reasonable	
21	Controller	1.58	Mos	15%		\$4,500.00	\$ 7,110.00	30,000.00	\$ 360,000.00	173.08 Reasonable	
22	Transportation/Fuel	1.58	Mos	100%		\$1,950.00	\$ 3,081.00	1,950.00	\$ 23,400.00	11.25 Reasonable	
23	Telephone/I, T & Data	1.58	Mos	100%		\$750.00	\$ 1,185.00	750.00	\$ 9,000.00	4.33 Reasonable	
24	Temporary Water (Potable)	1.58	Mos	100%		\$80.00	\$ 94.80	60.00	\$ 720.00	0.35 Reasonable	
25	Document control Software Acctg Software	1.58	Mos	100%		\$1,200.00	\$ 1,896.00	1,200.00	\$ 14,400.00	6.92 Reasonable	
26	Safety & First Aid	1.58	Mos	100%		\$150.00	\$ 237.00	150.00	\$ 1,800.00	0.87 Reasonable	
27	Fences/Baricades & tool storage	1.58	Mos	100%		\$740.00	\$ 1,169.20	740.00	\$ 8,880.00	4.27 Reasonable	
28	Temporary Toilets	1.58	Mos	100%		\$682.00	\$ 1,078.56	682.00	\$ 8,184.00	3.93 Reasonable	
29	Misc Expenses	1.58	Mos	100%		\$240.00	\$ 379.20	240.00	\$ 2,880.00	1.38 Reasonable	
30	Bonds & Insurance	2.50%				\$156,693	See Summary				
31											
32	LABOR:										
33	See above breakdown	0.00		0.00							
34											
35	EQUIPMENT:										
36	See above breakdown	0.00	EA	0.00					\$ -	\$ -	
37											
38											
39	SHEET TOTALS						\$166,693	\$ 99,173	\$1,180,071.59	per year	\$ -
40	GENERAL CONDITIONS FOR EXTENDED DURATION				Cal Days	Equivalent Mos.	Monthly GC				
41	TOTAL AMOUNT INCL. BOND & INSURANCE			\$ 160,610	48.00	1.58	\$101,651.75	Comparable to Original Monthly General Conditions			
42											
43	ORIGINAL CONTRACT GENERAL CONDITIONS						Monthly GC				
44	TOTAL AMOUNT INCL. BOND & INSURANCE PREMIUM PER SCHEDULE OF VALUES			\$1,591,676	434.00	14.27	\$118,547.74				
45											
46											
47											
48										\$ -	

ID	Task Name	Duration	Start	Finish	Late Finish	Predecessors	Successors
1	Admin	200 days	5/26/22	30/08/23	8/1/23		
5	Final Completion	1 day	30/10/23	30/10/23	8/1/23	3,4	
271	Phase 3 - MEP Building	327 days	7/17/22	10/0/23	0/0/23		
272	DG Building Footings and Grade Basins	10 days	9/1/22	9/10/22	7/29/22	217,404	273,277
274	Footings Rebar	10 days	10/15/22	10/26/22	9/19/22	273,73,83,406	276,277
399	Impact Analysis	78 days	7/17/22	10/11/22	8/2/22		
400	801 57 - Diagonal Braces - Review Answer	3 days	7/17/22	7/13/22	7/13/22	9,7	401,405,5
401	Beam Frame Redesign Coordination w/ Owner/PA/MSI	8 days	7/12/22	7/21/22	5/16/22	400	402
402	Diagonal Bracing Redesign	25 days	7/12/22	8/06/22	6/20/22	401	405
403	Unable to start Footings Without Diaphragm	39 days	7/17/22	8/06/22	7/14/22	400,5	404
404	All Divided to Proceed with Digging Footings	1 day	8/24/22	8/24/22	7/15/22	403	272
405	804 CCD 04" Redesign Review	15 days	8/24/22	9/08/22	7/13/22	402	406
406	CCD 04 Concrete Reinforcing Rebar/Detail	7 days	9/04/22	9/04/22	7/20/22	405	407
407	CCD 04 Concrete Reinforcing Rebar/Detail Approval	2 days	9/27/22	9/28/22	7/22/22	406	478
408	Procurement	10 days	9/28/22	10/13/22	8/5/22	407	274

Half 2, 2022 | Half 1, 2023 | Half 2, 2023
M | J | J | A | S | O | N | D | J | F | M | A | M | J | J | A | S | O | N

IH Concrete
IH Concrete

Task: Inactive Task, Inactive Milestone, Inactive Summary, Manual Task, Duration-only

Milestone: Start-only, Field-only, Critical Split, External Milestone

Summary: Project Summary, Manual Summary, External Tasks

Manual Progress: Manual Summary Rollup, Manual Summary, Start-only, Field-only, External Tasks

OAKLAND UNIFIED SCHOOL DISTRICT

Division of Facilities Planning and Management • 955 High Street Oakland, California 94601 • Phone 510/535-2728 • Fax 510/535-7040

(Proposed Change Order) No. 3

PROJECT: Claremont Middle School MPR & Kitchen Project

DATE: OCTOBER 30, 2024

OWNER: OAKLAND UNIFIED SCHOOL DISTRICT

DSA FILE NO.: 01-119337

CONTRACTOR: ARNTZ BUILDERS INC.

DSA APP NO.: 01-119337

431 Payran

OUSD PROJECT #: 15127

Petaluma, CA 94952

PROJECT MANAGER: JaQuan Cornish

Contractor hereby submits this Change Order Request ("COR") pursuant to the contract documents, including but not limited to General Conditions sections 4.5.1, 4.5.2, 7.6, 7.7, 8.4.1, and 8.4.2.

DESCRIPTION OF PROPOSED CHANGES IN WORK (specifically refer to attached pages or incorporated documents): **PCO 75 – Site Work Acceleration (Owner's Request):** Due to unforeseen conditions throughout the site, contract work was delayed. Extended workdays and weekend work was performed to complete the work before the start of school date of August 7, 2023.

OTHER PROPOSED CHANGES TO THE CONTRACT:

PCOs: #27, #58, #97, #120, #128, #139, #143, #144 & #146

PROPOSED ADJUSTMENT TO CONTRACT PRICE: \$21,446.67

PROPOSED ADJUSTMENT TO CONTRACT TIME: 0 calendar days

REASON FOR REQUEST (check one or more):

- Unforeseen Conditions
- Direction by Government Agency
- Owner Requested
- Design Omission
- Design Error
- Other: _____

OAKLAND UNIFIED SCHOOL DISTRICT

Division of Facilities Planning and Management • 955 High Street Oakland, California 94601 • Phone 510/535-2728 • Fax 510/535-7040

CERTIFICATION

I, Robert Arntz [name of declarant], declare the following:

Arntz Builders Inc. [Contractor company name] has contracted with Oakland Unified School District [public entity name] for the Claremont Middle School MPR & Kitchen Contract ("Contract"). Arntz Builders Inc. [Contractor company name] authorized me to prepare the attached Change Order Request ("COR") for money and/or time extension for Oakland Unified School District [public entity name] regarding this Contract (such COR being dated October 30, 2024, and entitled Change Order 1 and requesting \$2,153.35 and/or 0 additional days), and I prepared the attached COR. I am the most knowledgeable person at Arntz Builders Inc. [Contractor company name] regarding this COR.

The attached COR complies with all laws applicable to submission of a COR, including but not limited to California Penal Code section 72, Government Code sections 12650 et seq. (False Claims Act), and Business and Professions Code sections 17200 et seq. (Unfair Business Practices Act). I am aware that submission or certification of false claims, or other claims that violate law or the Contract, may lead to fines, imprisonment, and/or other serious legal consequences for myself or Arntz Builders [Contractor company name].

The attached COR does not breach the Contract, is not a false claim, does not violate any applicable law, satisfies all provisions of the Contract applicable to submission of the COR, only contains truthful and accurate supporting data, and only requests money and/or time extensions that accurately reflect the adjustments to money and time for which I believe that Oakland Unified School District [public entity name] is responsible under its Contract with Arntz Builders Inc. [Contractor company name].

While preparing this declaration and COR I consulted with others (including attorneys, consultants, or others who work for Arntz Builders Inc. [Contractor company name]) when necessary to ensure that the statements were true and correct.

Contractor understands and agrees that any COR submitted without this certification does not meet the terms of the Contract Documents; that Owner, or Owner's representatives, may reject the COR on that basis; and that unless Contractor properly and timely files the COR with the certification, Contractor cannot further pursue the COR in any forum and all rights to additional money or time for the issues covered by the COR are waived due to a condition precedent not having been satisfied.

I declare under the penalty of perjury under the laws of the State of California that the foregoing is true and correct. Executed October 30, 2024, at Oakland, California.

 [signature]

Robert Arntz [name of declarant]



Arntz Builders, Inc.

431 Payran St, Petaluma CA 94952 License No. 856393 T (707) 835-2900 F (707) 835-2993 www.amtzbuilders.com

Date: 6/20/23

Project Name: 2205 Claremont MS MPR & Kitchen

Generating Document: OUSD Direction

Arntz File #: 075

Arntz File Title: Site Work Acceleration

NOTIFICATION OF EXTRA:

The above referenced issue constitutes a changed condition resulting in extra work and extra costs. This condition will impact the project schedule.

Scope Change: Due to unforeseen conditions throughout the site, contract work has been delayed. With school starting back on August 7th, 2023, work days have been extended and weekend work has begun. Premium time costs for acceleration of contract site work will be tracked under this file.

Premium time for change order work will be tracked under the corresponding change order file for that work. +

Location: Site Work



Arntz Builders, Inc.

431 Payran St, Petaluma CA 94952 License No. 856393 T (707) 835-2900 F (707) 835-2993 www.arntzbuilders.com

March 15, 2024

Oakland Unified School District

1000 Broadway, Ste 300
Oakland, CA 94607

Subject : Claremont MS New Multi-Purpose and Kitchen
File No. 75.1 Site Work Acceleration

Good Afternoon,

Due to unforeseen conditions throughout the site, contract work has been delayed. With school starting back on August 7th, 2023, work days have been extended and weekend work has begun. Premium time costs for acceleration of contract site work will be tracked under this file.

Premium time for change order work will be tracked under the corresponding change order file for that work.

Prime Work:

Labor		\$14,564.00
Material		\$0.00
Equipment/Other		\$0.00
Prime Subtotal		\$14,564.00
Mark-Up	15.0%	\$2,184.60
Prime Total		\$16,748.60

Subcontractor Work:

WR Forde		\$4,474.35
Subcontractor Subtotal		\$4,474.35
Mark-Up	5.00%	\$223.72
Total Subcontractor Quotation		\$4,698.07

TOTAL PRIME & SUBCONTRACTOR QUOTATION **\$21,446.67**

We reserve the right to submit a claim for an extension of time and for all related delay and inefficiency costs that may result due to the changed condition. The extent and amount will be determined at a later date when the full impact of changed condition can be evaluated and determined. All rights and remedies are reserved.

Sincerely,

ARNTZ BUILDERS

Robert Arntz
Project Manager

cc:
ST
enc

Time & Material Tag

Date: 6-15-23
 Project Name: Claremont Middle School MPR & Kitchen
 Job #: 2205
 File #: _____
 Prime/Sub: _____



431 Payran St, Pealuma CA 94952
 License No. 856393
 T (707) 835-3900 F (707) 835-3993
 www.armtsbuilders.com

SCOPE: REMAINED ONSITE TO ALLOW FOR ACCELERATION.

PERSONNEL - TRADE CLASSIFICATION AND HOURS:

Name	Classification	Straight Time	OT	DT
<u>COLE AZAMAR</u>	<u>FOREMAN</u>		<u>2</u>	
			<u>2</u>	

MATERIALS - TYPE, QUANTITY, UNIT

MATERIAL	QUANTITY	UNIT

EQUIPMENT - TYPE, QUANTITY, UNIT

EQUIPMENT	QUANTITY	UNIT

Supervisor Signature

Authorized Signature

Date

VERIFY TIME ONLY
Supervisor (OR)
6-15-23

Time & Material Tag

Date: 6-17-23
 Project Name: Claremont Middle School MPR & Kitchen
 Job #: 2205
 File #: _____
 Prime/Sub: _____



431 Payran St, Petaluma CA 94952
 License No. 856393
 T (707) 835-2980 F (707) 835-2993
 www.arntzbuilders.com

SCOPE: ONSITE TO ALLOW FOR ACCELERATION OF SITEWORK BEFORE SCHOOL STARTS BACK

PERSONNEL - TRADE CLASSIFICATION AND HOURS:

Name	Classification	Straight Time	OT	DT
<u>COLE AZAMAR</u>	<u>FOREMAN</u>		<u>8</u>	
			<u>8</u>	

MATERIALS - TYPE, QUANTITY, UNIT

MATERIAL	QUANTITY	UNIT

EQUIPMENT - TYPE, QUANTITY, UNIT

EQUIPMENT	QUANTITY	UNIT

Supervisor Signature

Authorized Signature

Date

TEMP ONLY [Signature]
6-17-23

Time & Material Tag

Date: 6-20-23
 Project Name: Claremont Middle School MPR & Kitchen
 Job #: 2205
 File #: 15
 Prime/Sub: _____



431 Payrao St, Petaluma CA 94952
 License No. 856393
 T (707) 835-2900 F (707) 835-2993
 www.arabzaldora.com

SCOPE: SITEWORK ACCELERATION OF CONCRETE FORMWORK AND REBAR. PREMIUM TIME ONLY.

PERSONNEL - TRADE CLASSIFICATION AND HOURS:

Name	Classification	Straight Time	OT	DT
COLE AZAMAR	FOREMAN		2	
EAMON SHINE	CARP A		2	
JOSE MAGDALENO	CARP		2	
RUDOLFO CORONADAS	CARP		2	
JESUS CAUKIRO	LAB		2	
			10	

MATERIALS - TYPE, QUANTITY, UNIT

MATERIAL	QUANTITY	UNIT

EQUIPMENT - TYPE, QUANTITY, UNIT

EQUIPMENT	QUANTITY	UNIT

Supervisor Signature

Authorized Signature

Date

VERIFY T&M ONLY
STEVE T. KAY (ID#)
6-20-23

Time & Material Tag

Date: 6-22-23
 Project Name: Claremont Middle School MPR & Kitchen
 Job #: 2205
 File #: 75
 Prime/Sub: _____



431 Payrae St, Petaluma CA 94952
 License No. 856393
 T (707) 835-2900 F (707) 835-2953
 www.arabbuilders.com

SCOPE: REMAINED ONSITE TO ALLOW FOR SITE ACCELERATION.

PERSONNEL - TRADE CLASSIFICATION AND HOURS:

Name	Classification	Straight Time	OT	OT
<u>COLE AZAMAR</u>	<u>FOREMAN</u>		<u>2</u>	
			<u>2</u>	

MATERIALS - TYPE, QUANTITY, UNIT

MATERIAL	QUANTITY	UNIT

EQUIPMENT - TYPE, QUANTITY, UNIT

EQUIPMENT	QUANTITY	UNIT

Supervisor Signature _____

Authorized Signature _____

Date _____

VERIFIED TIME ONLY
COLE AZAMAR (10/2)
6-22-23

Time & Material Tag

Date: 6-24-23
 Project Name: Clermont Middle School MPR & Kitchen
 Job #: 2205
 File #: 75
 Prime/Sub: _____



431 Payran St, Petaluma CA 94952
 License No. 856393
 T (707) 835-2900 F (707) 835-3993
 www.arnoldbuilders.com

SCOPE:  ONSITE TO ALLOW FOR SITE ACCELERATION OF SITE WORK PRIOR TO AUGUST 7TH.

PERSONNEL - TRADE CLASSIFICATION AND HOURS:

Name	Classification	Straight Time	OT	DT
COLE AZAMAR	FORE.		8	
			8	

MATERIALS - TYPE, QUANTITY, UNIT

MATERIAL	QUANTITY	UNIT

EQUIPMENT - TYPE, QUANTITY, UNIT

EQUIPMENT	QUANTITY	UNIT

Supervisor Signature

Authorized Signature

Date

VERITY TEAM
SEPT. R.
6-24-23

Time & Material Tag

Date: 6-27-23
 Project Name: Claremont Middle School MPR & Kitchen
 Job #: 2205
 File #: 75
 Prime/Sub: _____



431 Payran St, Peabunna CA 94952
 License No. 8353993
 T (707) 835-2900 F (707) 835-2993
 www.arutzbuilders.com

SCOPE: REMAINED ONSITE TO ALLOW FOR ACCELERATION OF SITE WORK.

PERSONNEL - TRADE CLASSIFICATION AND HOURS:

Name	Classification	Straight Time	OT	DT
<u>COLE AZAMAR</u>	<u>FORE.</u>		<u>2</u>	
			<u>2</u>	

MATERIALS - TYPE, QUANTITY, UNIT

MATERIAL	QUANTITY	UNIT

EQUIPMENT - TYPE, QUANTITY, UNIT

EQUIPMENT	QUANTITY	UNIT

Supervisor Signature _____

Authorized Signature _____

Date _____

VERIFIED T&M ONLY [Signature]
6-27-23

Time & Material Tag

Date: 6-29-23
 Project Name: Claremont Middle School MPR & Kitchen
 Job #: 2205
 File #: 75
 Prime/Sub: _____



431 Payran St, Petaluma CA 94952
 License No. 856393
 T (707) 835-2900 F (707) 835-2993
 www.arnbuilders.com

SCOPE: **REMAINED ONSITE TO ALLOW FOR SITE ACCELERATION OF CIVIL WORK.**

PERSONNEL - TRADE CLASSIFICATION AND HOURS:

Name	Classification	Straight Time	OT	DT
EAMON SHINE	CARP A		2	
			2	

MATERIALS - TYPE, QUANTITY, UNIT

MATERIAL	QUANTITY	UNIT

EQUIPMENT - TYPE, QUANTITY, UNIT

EQUIPMENT	QUANTITY	UNIT

Supervisor Signature

Authorized Signature

Date

VERIFIED TO MOBILE SITE (see)
6-29-23

Time & Material Tag

Date: 7-5-23
 Project Name: Claremont Middle School MPR & Kitchen
 Job #: 2205
 File #: 75
 Prime/Sub: _____



431 Payson St, Petaluma CA 94952
 License No. 856393
 T (707) 836-2900 F (707) 836-2993
 www.arntbuilders.com

SCOPE: REMAINED ONSITE TO ALLOW FOR ACCELERATION OF SITE WORK BEFORE SCHOOL STARTS

PERSONNEL - TRADE CLASSIFICATION AND HOURS:

Name	Classification	Straight Time	OT	DT
<u>COLE AZAMAR</u>	<u>FORE.</u>		<u>2</u>	
			<u>2</u>	

MATERIALS - TYPE, QUANTITY, UNIT

MATERIAL	QUANTITY	UNIT

EQUIPMENT - TYPE, QUANTITY, UNIT

EQUIPMENT	QUANTITY	UNIT

Supervisor Signature

Authorized Signature

Date

Blufford Tomlinson
7-5-23

Time & Material Tag

Date: 07/07/2023
 Project Name: Claremont Middle School MPR & Kitchen
 Job #: 2205
 File #: 75
 Prime/Sub: _____



431 Puyun St, Petaluma CA 94952
 License No. 836393
 T (707) 835-2900 . F (707) 835-2993
 www.srntbuilders.com

SCOPE:
 Remained onsite to allow for acceleration of site work before school starts.

PERSONNEL - TRADE CLASSIFICATION AND HOURS:

Name	Classification	Straight Time	OT	DT
Cole Azamar	FORE		2	

MATERIALS - TYPE, QUANTITY, UNIT

MATERIAL	QUANTITY	UNIT

EQUIPMENT - TYPE, QUANTITY, UNIT

EQUIPMENT	QUANTITY	UNIT

Supervisor Signature

Authorized Signature

Date

VERIFIED TOMMY - *[Signature]*

Time & Material Tag

Date: 07/10/2023
 Project Name: Claremont Middle School MPR & Kitchen
 Job #: 2205
 File #: 75
 Prime/Sub: _____



431 Payran St, Palmdale CA 94952
 License No. 856393
 T (707) 835-2900 F (707) 835-2903
 www.srmtbuilders.com

SCOPE:
 Remained onsite to allow for acceleration of site work before school starts.

PERSONNEL - TRADE CLASSIFICATION AND HOURS:

Name	Classification	Straight Time	OT	DT
Cole Azamar	FORIE		2	

MATERIALS - TYPE, QUANTITY, UNIT

MATERIAL	QUANTITY	UNIT

EQUIPMENT - TYPE, QUANTITY, UNIT

EQUIPMENT	QUANTITY	UNIT

Supervisor Signature

Authorized Signature

Date

Verified by M. J. [Signature]

Time & Material Tag

Date: 07/12/13
 Project Name: Claremont Middle School MPR & Kitchen
 Job #: 2205
 File #: 75
 Prime/Sub: _____



431 Payson St, Petaluma CA 94953
 License No. 856393
 T (707) 835-2980 F (707) 835-2983
 www.srnitzbuilders.com

SCOPE:
 Remained Onsite to allow for acceleration of site work before school starts

PERSONNEL - TRADE CLASSIFICATION AND HOURS:

Name	Classification	Straight Time	OT	DT
Cole Azamar	FORE		2	

MATERIALS - TYPE, QUANTITY, UNIT

MATERIAL	QUANTITY	UNIT

EQUIPMENT - TYPE, QUANTITY, UNIT

EQUIPMENT	QUANTITY	UNIT

Supervisor Signature

Authorized Signature

[Handwritten Signature]

Date

Time & Material Tag

Date: 07/14/23
 Project Name: Claremont Middle School MPR & Kitchen
 Job #: 2205
 File #: 75
 Prime/Sub: _____



431 Payran St, Petaluma CA 94952
 License No. 850390
 T (707) 835-2900 F (707) 835-2953
 www.srntbuilders.com

SCOPE:
 Remained Onsite to allow for acceleration of site work before school starts.

PERSONNEL - TRADE CLASSIFICATION AND HOURS:

Name	Classification	Straight Time	OT	DT
Erwin Shine	CARP A		2	
Rose Magdalena	CARP		2	
Johnathan Taffola	CARP A		2	
Rudolfo Coronados	CARP		2	

MATERIALS - TYPE, QUANTITY, UNIT

MATERIAL	QUANTITY	UNIT

EQUIPMENT - TYPE, QUANTITY, UNIT

EQUIPMENT	QUANTITY	UNIT

Supervisor Signature _____

Authorized Signature _____

Date _____

TEAM ONLY - J. P. S. & (over)

Time & Material Tag

Date: 07/17/2023
 Project Name: Claremont Middle School MPR & Kitchen
 Job #: 2205
 File #: 75
 Prime/Sub: _____



431 Payton St, Fontana CA 92331
 License No. 826393
 T (707) 836-2980 F (707) 836-2983
 www.sratzbuilders.com

SCOPE:
 Remained onsite to allow for acceleration of site work before school starts

PERSONNEL - TRADE CLASSIFICATION AND HOURS:

Name	Classification	Straight Time	OT	DT
Sole Azamar	FORE		2	
Francisco Becerra	LAB		2	
Jesus Calixtro	LAB		2	
Eugenio Maldonado	LAB		2	

MATERIALS - TYPE, QUANTITY, UNIT

MATERIAL	QUANTITY	UNIT

EQUIPMENT - TYPE, QUANTITY, UNIT

EQUIPMENT	QUANTITY	UNIT

Supervisor Signature

Authorized Signature

Date

VERIFIED TERRY MARY (IC)

Time & Material Tag

Date: 07/14/23
 Project Name: Claremont Middle School MPR & Kitchen
 Job #: 2205
 File #: 75
 Prime/Sub: _____



491 Peyton St, Petaluma CA 94952
 License No. 856395
 T (707) 835-2960 F (707) 835-2963
 www.svntbuilders.com

SCOPE:
 Remained onsite to allow for acceleration of site work before school starts

PERSONNEL - TRADE CLASSIFICATION AND HOURS:

Name	Classification	Straight Time	OT	DT
Cole Azamar	FORE		2	
Eamon Shine	CARPA		2	
Jose Magdaleno	CARP		2	
Jose Rodriguez	EAB		2	
Jonathan Takkola	CARPA		2	
Musa Dunbar	CARP		2	
Francisco Becerra			2	
Jesus Calinbro			2	
Daniel Orozco			2	
Alejo Morales			2	

MATERIALS - TYPE, QUANTITY, UNIT

MATERIAL	QUANTITY	UNIT

EQUIPMENT - TYPE, QUANTITY, UNIT

EQUIPMENT	QUANTITY	UNIT

Supervisor Signature _____

Authorized Signature _____

Date _____

VERIFIED T&M ONLY *[Signature]*

Time & Material Tag

Date: 07/21/23
 Project Name: Claremont Middle School MPR & Kitchen
 Job #: 2205
 File #: 75
 Prime/Sub: _____



431 Payran St, Petaluma CA 94952
 License No. 856393
 T (707) 835-2900 F (707) 835-2993
 www.sratzbuilders.com

SCOPE:
 Remained onsite to allow for acceleration at site work before school starts. Finished forming College Ave curbs and slabwork in preparation for concrete. Pour planter footing and curb.

PERSONNEL - TRADE CLASSIFICATION AND HOURS:

Name	Classification	Straight Time	OT	DT
Eamon Shine	CARP A		2	
Francisco Becerra	LAB		2	
Jesus Calixtro	LAB		2	
Jose Rodriguez	LAB		2	
Musa Dunbar	CARP		2	
Alonso Morales	LAB		2	
Carlos Morales	LAB		2	
Moises Morales	LAB		2	
Cole Azamar	FORE		2	

MATERIALS - TYPE, QUANTITY, UNIT

MATERIAL	QUANTITY	UNIT

EQUIPMENT - TYPE, QUANTITY, UNIT

EQUIPMENT	QUANTITY	UNIT

Supervisor Signature

Authorized Signature

Date

VERIFIED TESTIMONY - *[Signature]* (oe)

Time & Material Tag

Date: 07/24/23
 Project Name: Claremont Middle School MPR & Kitchen
 Job #: 2285
 File #: 75
 Prime/Sub: _____



431 Payson St, Petaluma CA 94952
 License No. 856393
 T (707) 835-2900 F (707) 835-2993
 www.azatabuilders.com

SCOPE:
 Remained onsite to allow for acceleration of site work before school starts. continued forming flatwork and began site caulking expansion joints in concrete flatwork

PERSONNEL - TRADE CLASSIFICATION AND HOURS:

Name	Classification	Straight Time	OT	DT
Cole Azamar	FORE		2	
Eamon Shine	CARP		2	
Jose Magdaleno	CARP		2	
Francisco Becerra	LAB		2	
Jesus Calixtro	LAB		2	
Daniel Rosso	LAB		2	
Jose Rodriguez	LAB		2	
Alonso Morales	LAB		2	
Moises Morales	LAB		2	
Carlos Morales	LAB		2	

MATERIALS - TYPE, QUANTITY, UNIT

MATERIAL	QUANTITY	UNIT

EQUIPMENT - TYPE, QUANTITY, UNIT

EQUIPMENT	QUANTITY	UNIT

Supervisor Signature _____

Authorized Signature _____

Date _____

VERIFIED T&M ONLY Sup. J. Lopez (102)

Time & Material Tag

Date: 07/26/23
 Project Name: Claremont Middle School MPR & Kitchen
 Job #: 2205
 File #: 75
 Prime/Sub: _____



431 Payrae St, Petaluma CA 94952
 License No. 856393
 T (707) 835-2900 F (707) 835-2993
 www.arutzbuilders.com

SCOPE:
 Remained Onsite to allow for acceleration of site work before school starts. Continued installing pavers and began site caulking new concrete flatwork. Began Layout and installation of canopy for 2-Birt.

PERSONNEL - TRADE CLASSIFICATION AND HOURS:

Name	Classification	Straight Time	OT	DT
Cole Azamar	FORE		2	
Eamon Shine	CARP A		2	
Jose Magdaleno	CARP		2	
Rudolfo Coronados	CARP		2	
Francis Becerra	LAB		2	
Jesus Calixtro	LAB		2	
Jose Rodriguez	LAB		2	
Alonso Morales	LAB		2	
Moises Morales	LAB		2	
Carlos Morales	LAB		2	
MATERIALS - TYPE, QUANTITY, UNIT			2	

MATERIAL	QUANTITY	UNIT

EQUIPMENT - TYPE, QUANTITY, UNIT

EQUIPMENT	QUANTITY	UNIT

Supervisor Signature

Authorized Signature

VERIFIED ITEM

Date

Time & Material Tag

Date: 07/31/13
 Project Name: Claremont Middle School MPR & Kitchen
 Job #: 2205
 File #: 75
 Prime/Sub: _____



431 Payton St, Petaluma, CA 94952
 License No. 856393
 T (707) 835-2900 F (707) 835-2993
 www.arntzbuilders.com

SCOPE:
 Remained onsite to allow for site acceleration before school starts

PERSONNEL - TRADE CLASSIFICATION AND HOURS:

Name	Classification	Straight Time	OT	DT
Eamon Shine	CARPA		2.5	

MATERIALS - TYPE, QUANTITY, UNIT

MATERIAL	QUANTITY	UNIT

EQUIPMENT - TYPE, QUANTITY, UNIT

EQUIPMENT	QUANTITY	UNIT

Supervisor Signature _____

Authorized Signature _____

Date _____

Verified T&M ONLY - [Signature]

Time & Material Tag

Date: 8-2-23
 Project Name: Claremont Middle School MPR & Kitchen
 Job #: 2205
 File #: 75
 Prime/Sub: _____



431 Payran St, Petaluma CA 94952
 License No. 856393
 T (707) 835-2900 F (707) 835-2993
 www.amtbuilder.com

SCOPE:
 Remained onsite to allow for acceleration of site work before school starts.

PERSONNEL - TRADE CLASSIFICATION AND HOURS:

Name	Classification	Straight Time	OT	DT
Cole Azanas	FORP		2	

MATERIALS - TYPE, QUANTITY, UNIT

MATERIAL	QUANTITY	UNIT

EQUIPMENT - TYPE, QUANTITY, UNIT

EQUIPMENT	QUANTITY	UNIT

Supervisor Signature _____

Authorized Signature _____

Date _____

VERIFIED T&M ONLY - [Signature]

Time & Material Tag

Date: 8/5/23
 Project Name: Claremont Middle School MPR & Kitchen
 Job #: 2205
 File #: 75
 Prime/Sub: _____



431 Payran St, Petaluma CA 94952
 License No: 856393
 T (707) 835-2900 F (707) 835-2993
 www.arntzbuilders.com

SCOPE: ONSITE TO ALLOW FOR SITEWORK ACCELERATION.

PERSONNEL - TRADE CLASSIFICATION AND HOURS:

Name	Classification	Straight Time	OT	DT
<u>COLE AZAMAR</u>	<u>FORE</u>		<u>8</u>	
			<u>8</u>	

MATERIALS - TYPE, QUANTITY, UNIT

MATERIAL	QUANTITY	UNIT

EQUIPMENT - TYPE, QUANTITY, UNIT

EQUIPMENT	QUANTITY	UNIT

Supervisor Signature

Authorized Signature

James T. M... (id)

Date

Time & Material Tag

Date: 8-8-23
 Project Name: Claremont Middle School MPR & Kitcher
 Job #: 2205
 File #: 75
 Prime/Sub: _____



431 Payran St, Petaluma CA 94952
 License No. 856393
 T (707) 835-2900 F (707) 835-2993
 www.arntzbuilders.com

SCOPE:
Remained onsite to allow for site acceleration.

PERSONNEL - TRADE CLASSIFICATION AND HOURS:

Name	Classification	Straight Time	OT	DT
<u>Eamon Shine</u>	<u>CARP A</u>		<u>2.5</u>	

MATERIALS - TYPE, QUANTITY, UNIT

MATERIAL	QUANTITY	UNIT

EQUIPMENT - TYPE, QUANTITY, UNIT

EQUIPMENT	QUANTITY	UNIT

Supervisor Signature _____

Authorized Signature _____

Date _____

VERIFIED TSM/2024: [Signature]

Time & Material Tag

Date: 08-10-23
 Project Name: Claremont Middle School MPR & Kitchen
 Job #: 2205
 File #: 75
 Prime/Sub: _____



431 Payran St, Petaluma CA 94952
 License No. 856393
 T (707) 835-2900 F (707) 835-2993
 www.arntzbuilders.com

SCOPE:
 Remained onsite to allow acceleration of site work.

PERSONNEL - TRADE CLASSIFICATION AND HOURS:

Name	Classification	Straight Time	OT	OT
Eamon Shine	CARP A		2	

MATERIALS - TYPE, QUANTITY, UNIT

MATERIAL	QUANTITY	UNIT

EQUIPMENT - TYPE, QUANTITY, UNIT

EQUIPMENT	QUANTITY	UNIT

Supervisor Signature _____

Authorized Signature _____

Date _____

VERIFIED T&M only [Signature]

Time & Material Tag

Date: 08-12-23
 Project Name: Claremont Middle School MPR & Kitchen
 Job #: 2205
 File #: 75
 Prime/Sub: _____



431 Payson St, Petaluma CA 94952
 License No. 856393
 T (707) 835-2900 F (707) 835-2993
 www.arnitzbuilders.com

SCOPE:
 Worked Saturday to over see Fire Alarm Testing.

PERSONNEL - TRADE CLASSIFICATION AND HOURS:

Name	Classification	Straight Time	OT	DT
Cole Azamar	FORE		5	
			6	

MATERIALS - TYPE, QUANTITY, UNIT

MATERIAL	QUANTITY	UNIT

EQUIPMENT - TYPE, QUANTITY, UNIT

EQUIPMENT	QUANTITY	UNIT

Supervisor Signature _____

Authorized Signature _____

Date _____

VERIFIED T&M ONLY - Steph. S. (JCR)



ENGINEERING CONSTRUCTION

CA LICENSE #1025859 • DIR #1000048412

984 HENSLEY STREET • RICHMOND, CA 94801-2117 • PHONE: 510.215.9338

BID FAX: 510.215.9867 • RECEPTION FAX: 510.215.7028

BILL TO
Arntz Builders Attention: Robert Arntz 431 Payran Street Petaluma, CA 94925 Telephone: (707) 835-2900 Fax: (707) 835-2993 rtarntz@arntzbuilders.com

DATE
08/15/23

2022-20 - WRF File #24

Job No.	JOB LOCATION
2022-20	Claremont Middle School, Oakland, CA

Work Date	Sales Order	Short Description	Amount
06/20/23	01069	Excavated Electrical Trench, Graded for Fire...	\$ 509.29
06/21/23	01070	Grading for Fire Road.	\$ 383.59
06/22/23	01071	Excavate Fire Lane Grading Area.	\$ 383.59
06/23/23	01073	Backfilled trench for 8" Storm Drain Grade...	\$ 308.18
06/26/23	01075	Remained Onsite to Accelerate Site Work by...	\$ 631.90
07/06/23	01235	Grade Under Canopy at Pavers, Grade Along ...	\$ 257.90
07/11/23	05930	Grade for Flatwork.	\$ 358.46
07/12/23	05931	Working Overtime on Contract Work to Accel...	\$ 358.46
07/13/23	01238	Remaining Onsite to Allow for Acceleration...	\$ 358.46
07/14/23	01239	Set Boxes to Grade and Filled Planters.	\$ 308.18
07/18/23	01083	Site Acceleration.	\$ 308.18
07/19/23	01084	Site Acceleration.	\$ 308.18
Total:			\$ 4,474.35



984 HENSLEY STREET
 RICHMOND, CA 94804
 PHONE (510) 215-9338
 FAX (510) 215-9867

FIELD SALES ORDER

SOLD TO:	Arntz	WORK DATE:	6/19/23
SPECIFIC ONSITE LOCATION / STATION:	Claremont Middle School		
COMPLETE DESCRIPTION OF WORK PERFORMED:	Back fill trench for Electrical		

POSITION	PERSONNEL	TOTAL WORK HOURS		
		REG	OFF	D.T.
Superintendent:		O.T.		
Foreman:	Juan P	2		
Operator:	Jose N	2		
Laborer:	Adrian, Alonso, Juan, Alfredo	10		
Teamster:	Efrén, b			
Other:				
Other:				

EQUIPMENT	HOURS	EQUIPMENT	HOURS	EQUIPMENT	HOURS
BACKHOE, # _____		TRANSPORT TRUCK		FORKLIFT, # _____	
SKIP LOADER, # _____		SUPER DUMP		BLADE, # _____	
ROAD GRADER		BOSTAIL		TRASH PUMP, # _____	
RUBBER TIRE LOADER, # _____		WORK TRUCK W/TOOLS	2	CCTV CAMERA + REEL	
TRACK LOADER, # _____		WATER TRUCK		PORTABLE GENERATOR	
DOZER, # _____		AC GRINDER		LASER	
EXCAVATOR, # <i>minicex</i>	2	PAVER		SIDEWINDER	
ROLLER, # _____		AIR COMPRESSOR W/TOOLS		SHORING	
COMPACTOR, # _____		WALK BEHIND WET SAW W/BLADE			
<i>minicex backhoe</i>	2				

(All materials, rentals and subcontractor field invoices must be attached to this Sales Order.)

SUB/SUPPLIER	SUPPLIER TAG NUMBER	QUANTITY	DESCRIPTION

BY-W.R.F. EMPLOYEE:	Juan M. Robledo	W.R.F. JOB#:	202220
OWNER/CLIENT SIGNATURE:		CLIENT REF#:	

The above equipment is working under the renter's full direction and supervision. Renter shall indemnify W. R. Forde Associates, Inc. against all claims, demands, costs, attorney fees and liability of every nature arising from injury to person or property or the economic interests of any party resulting from or alleged to result from renter's operations, performance or nonperformance. Such indemnity shall extend to all claims, demands and liability arising from the activities of the renter. This indemnity agreement applies to claims, demands and liability for injuries occurring after completion of the rental agreement, as well as during the performance of this agreement and extends to claims demands and liability for injury contributed by the negligence or the other misconduct of W. R. Forde Associates, Inc., as long as the injury is alleged to be or is caused in part by the negligence or misconduct of renter.

WRF File # <u>24</u>	VERIFIED T&M ONLY - <i>Steph T. Day (10K)</i>	TAG# 01068
----------------------	---	-------------------

OFFICE/PROCESSING



W.R. FORDE ASSOCIATES, INC.

984 HENSLEY STREET
RICHMOND, CALIFORNIA 94804
PHONE (510) 215-9338
FAX (510) 215-8867

2022-20 - WRF File #24

Table with 4 columns: SOLD TO, DATE, SALES NO, and WORK PERFORMED AT LOCATION / STATION. Includes details for Amiz Builders, 6/21/2023, 01070, and Claremont Middle School, Oakland, CA.

Large table with 8 columns: HOURS WORKED, EQUIPMENT, RATE, COLUMN "A" \$\$ TOTAL, HOURS WORKED, EQUIPMENT, RATE, COLUMN "B" \$\$ TOTAL. Lists various equipment like BACKHOE, EXCAVATOR, DOZER, etc.

TOTAL OF EACH COLUMN EQUIPMENT COST: \$ -

TOTAL COMBINED EQUIPMENT COLUMN COST-"A" & "B": \$ -

Table with 6 columns: SUB / SUPPLIER, INVOICE NUMBER, QUANTITY, DESCRIPTION, \$\$ VALUE, ROW \$\$ TOTAL. For materials and subcontractors.

TOTAL OF ALL MATERIALS OR SUBCONTRACTORS: \$ -

COMBINED SUBTOTAL OF ALL PERSONNEL, EQUIPMENT & MATERIALS OR SUBCONTRACTORS: \$ 333.56

15% OVERHEAD MARKUP \$ 50.03

GRAND TOTAL OF ALL PERSONNEL, EQUIPMENT & MATERIALS OR SUBCONTRACTORS AND MARKUP: \$ 383.59

Table with 4 columns: BY-W.R.F. EMPLOYEE, W.R.F. JOB #, OWNER / CLIENT REP. SIGNATURE, CLIENT REF. #.

The above equipment is working under the renter's full direction and supervision. Renter shall indemnify W.R. Forde Associates against all claims, demands, costs, attorney fees and liability of every nature arising from injury to person or property...



984 HENSLEY STREET
 RICHMOND, CA 94804
 PHONE (510) 215-8338
 FAX (510) 215-8867

FIELD SALES ORDER

SOLD TO:		WORK DATE:	
SPECIFIC ONSITE LOCATION / STATION:	Grading		
COMPLETE DESCRIPTION OF WORK PERFORMED:			

POSITION	PERSONNEL	TOTAL WORK HOURS		
		REG	O.T.	D.T.
Superintendent:				
Foreman:	JUAN P		2	
Operator:	HANK JUSG N		4	
Laborer:	Adrian Arnold		5	
Teamster:				
Other:				
Other:				

EQUIPMENT	HOURS	EQUIPMENT	HOURS	EQUIPMENT	HOURS
BACKHOE, #		TRANSPORT TRUCK		FORKLIFT, #	
SKIP LOADER, #		SUPER DUMP		BLADE, #	
ROAD GRADER		BOSTAIL		TRASH PUMP, #	
RUBBER TIRE LOADER, #		WORK TRUCK W/TOOLS	2	CCTV CAMERA + REEL	
TRACK LOADER, #		WATER TRUCK		PORTABLE GENERATOR	
DOZER, #		AC GRINDER		LASER	
EXCAVATOR, #	20.1	PAVER		SIDEWINDER	
ROLLER, #		AIR COMPRESSOR W/TOOLS		SHORING	
COMPACTOR, #		WALK BEHIND WET SAW W/BLADE			
	20.1				

(All materials, rentals and subcontractor field invoices must be attached to this Sales Order.)

SUB/SUPPLIER	SUPPLIER TAG NUMBER	QUANTITY	DESCRIPTION

BY-W.R.F. EMPLOYEE:		W.R.F. JOB#:	
OWNER/CLIENT SIGNATURE:		CLIENT REF#:	

The above equipment is working under the renter's full direction and supervision. Renter shall indemnify W. R. Forde Associates, Inc against all claims, demands, costs, attorney fees and liability of every nature arising from injury to person or property or the economic interests of any party resulting from or alleged to result from renter's operations, performance or nonperformance. Such indemnity shall extend to all claims, demands and liability arising from the activities of the renter. This indemnity agreement applies to claims, demands and liability for injuries occurring after completion of the rental agreement, as well as during the performance of this agreement and extends to claims demands and liability for injury contributed by the negligence or the other misconduct of W. R. Forde Associates, Inc, as long as the injury is alleged to be or is caused in part by the negligence or misconduct of renter.

WRF File #		TAG#	01070
------------	--	------	-------

OFFICE/RETAINED



984 HENSLEY STREET
 RICHMOND, CA 94804
 PHONE (510) 215-9338
 FAX (510) 215-9867

FIELD SALES ORDER

SOLD TO:	<i>Airtz</i>	WORK DATE:	<i>6/22/23</i>
SPECIFIC ONSITE LOCATION / STATION:	<i>Claremont middle school</i>		
COMPLETE DESCRIPTION OF WORK PERFORMED:	<i>Excavating Fire lane grading Area</i>		

POSITION	PERSONNEL	TOTAL WORK HOURS		
		REG	O.T.	D.T.
Superintendent:				
Foreman:	<i>JUAN P</i>		<i>2</i>	
Operator:	<i>Hank JOSE N</i>		<i>4</i>	
Laborer:	<i>Adrian, ALONSO, JUAN P</i>		<i>6</i>	
Teamster:				
Other:				
Other:				

EQUIPMENT	HOURS	EQUIPMENT	HOURS	EQUIPMENT	HOURS
BACKHOE, # _____		TRANSPORT TRUCK		FORKLIFT, # _____	
SKIP LOADER, # _____		SUPER DUMP		BLADE, # _____	
ROAD GRADER		BOBTAIL		TRASH PUMP, # _____	
RUBBER TIRE LOADER, # <i>Dumper</i>	<i>2.0T</i>	WORK TRUCK W/TOOLS		CCTV CAMERA + REEL	
TRACK LOADER, # _____		WATER TRUCK		PORTABLE GENERATOR	
DOZER, # _____		AC GRINDER		LASER	
EXCAVATOR, # <i>mini-ex35</i>	<i>2.0T</i>	PAVER		SIDEWINDER	
ROLLER, # _____		AIR COMPRESSOR W/TOOLS		SHORING	
COMPACTOR, # _____		WALK BEHIND WET SAW W/BLADE			
<i>excavator 60</i>	<i>2.0T</i>				

(All materials, rentals and subcontractor field invoices must be attached to this Sales Order.)

SUB/SUPPLIER	SUPPLIER TAG NUMBER	QUANTITY	DESCRIPTION

BY-W.R.F. EMPLOYEE:	<i>Juan Pablano</i>	W.R.F. JOB#:	<i>2022-20</i>
OWNER/CLIENT SIGNATURE:		CLIENT REF#:	

The above equipment is working under the renter's full direction and supervision. Renter shall indemnify W. R. Forde Associates, Inc. against all claims, demands, costs, attorney fees and liability of every nature arising from injury to person or property or the economic interests of any party resulting from or alleged to result from renter's operations, performance or nonperformance. Such indemnity shall extend to all claims, demands and liability arising from the activities of the renter. This indemnity agreement applies to claims, demands and liability for injuries occurring after completion of the rental agreement, as well as during the performance of this agreement and extends to claims demands and liability for injury contributed by the negligence or the other misconduct of W. R. Forde Associates, Inc., as long as the injury is alleged to be or is caused in part by the negligence or misconduct of renter.

WRF File # <i>24</i>	<i>VERIFIED TEMPORARY - SEPT 20102</i>	TAG# 01071
----------------------	--	-------------------

OFFICE/PROCESSING



W.R. FORDE ASSOCIATES, INC.

984 HENSLEY STREET
RICHMOND, CALIFORNIA 94804
PHONE (510) 215-9338
FAX (510) 215-9867

2022-20 - WRF File #24

SOLD TO: Amtz Builders	DATE: 6/23/2023	SALES NO: 01073
WORK PERFORMED AT LOCATION / STATION:	Claremont Middle School, Oakland, CA	
COMPLETE DESCRIPTION OF WORK PERFORMED:	Backfilled trench for 8" Storm Drain Graded Cut Area	
POSITION	PERSONNEL	TOTAL REG.
Foreman: Juan Poblano		O.T. \$ 35.62 \$ 71.24
Operator: Jose Navarro		O.T. \$ 32.79 \$ 65.58
Laborer: Adrian, Alonso, Juan D		O.T. \$ 21.86 \$ 131.16
Teamster:		O.T. \$ 23.46 \$ -
Super:		O.T. \$ 130.00 \$ -
Other:		O.T. \$ - \$ -
TOTAL OF ALL LABOR COLUMN COSTS:		\$ 267.98

HOURS WORKED	EQUIPMENT	RATE	COLUMN "A" \$\$ TOTAL	HOURS WORKED	EQUIPMENT	RATE	COLUMN "B" \$\$ TOTAL	
	BACKHOE 580: BH-8, 11, 14, 15, 17	\$ 61.31	\$ -		PAVING UNIT	\$ 98.25	\$ -	
	BACKHOE LARGE: BH-6, 7, 16	\$ 85.75	\$ -		ROLLER/COMPACTOR DIRT: R10	\$ 101.81	\$ -	
	BACKHOE W/HOE RAM ATTACHMENT	\$ 112.95	\$ -		ROLLER/COMPACTOR AC-2	\$ 82.64	\$ -	
	EXCAVATOR MINI: EX-1, 6, 9-14, 16, 17, 20, 21, 23, 25-27	\$ 49.49	\$ -		ROLLER/COMPACTOR ROCK: PAC-5	\$ 75.13	\$ -	
	EXCAVATOR- MID SIZE: EX-4, 5, 7, 18, 19, 22, 24	\$ 98.23	\$ -		ROLLER/COMPACTOR TURTLE PLATE-5	\$ 49.93	\$ -	
	EXCAVATOR - CAT 330: EX-8	\$ 201.62	\$ -		ROLLER BOMAG: R-3, 5, 7, 9, 11	\$ 42.64	\$ -	
	EXCAVATOR W/HOE RAM ATTACH.	\$ 104.96	\$ -		COMPACTOR- CAT	\$ 115.35	\$ -	
	DOZER JD-650K: BD-2	\$ 61.23	\$ -		COMPACTOR- WALK BEHIND SHEEPS FT.	\$ 39.79	\$ -	
	DOZER TD-8: BD-1	\$ 39.86	\$ -		COMPACTOR- VIBROPLATE/JUMPING JACK	\$ 12.18	\$ -	
	FORKLIFT: FL-1	\$ 82.39	\$ -		TRASH PUMP (2")	\$ 27.08	\$ -	
	FORKLIFT: FL-2	\$ 50.30	\$ -		TRASH PUMP (3")	\$ 29.99	\$ -	
	LOADER- SKIP: SL-1	\$ 74.82	\$ -		TRASH PUMP (4")	\$ 43.83	\$ -	
	LOADER- CAT 246D: L-4	\$ 37.22	\$ -		TRASH PUMP (6")	\$ 51.70	\$ -	
	LOADER- MUSTANG: L-1-3	\$ 43.27	\$ -		LEE BOY BLADE: BL-4	\$ 89.32	\$ -	
	LOADER- SKID STEER: TL-1	\$ 37.70	\$ -		ROAD GRADER/ BLADE: BL-1	\$ 100.46	\$ -	
	LOADER- TAKEUCCHI: TL-2	\$ 44.70	\$ -		14" CUT OFF SAW WDRY BLADE	\$ 20.92	\$ -	
	LOADER- RUBBER TIRE: WL-3 & 4	\$ 134.45	\$ -		WALK BEHIND WET SAW w/BLADE	\$ 20.14	\$ -	
	TRUCK- BOBTAIL	\$ 73.34	\$ -		MUSTANG GRINDER	\$ 87.17	\$ -	
	TRUCK- TRANSPORT	\$ 93.59	\$ -		LASER	\$ 65.00	\$ -	
	TRUCK- WATER/FUEL	\$ 73.34	\$ -		LASER LEVEL/GRADE CHECK EQUIP	\$ 38.69	\$ -	
	TRUCK- FLATBED	\$ 93.50	\$ -		VACCU TRAILER	\$ 158.50	\$ -	
	TRUCK- SUPER DUMP	\$ 93.59	\$ -		AIR COMPRESSOR W/ TOOLS	\$ 48.69	\$ -	
	TRUCK- WORK W/ TOOLS	\$ 63.63	\$ -		PORTABLE GENERATOR	\$ 18.03	\$ -	
	ROCKWHEEL- VERMEER V-650	\$ 135.22	\$ -		STEEL PLATES	\$ 15.50	\$ -	
	ROCKWHEEL- VERMEER V-850	\$ 249.76	\$ -		WATER BUGGY	\$ 45.00	\$ -	
	DUMPER - TEREX: D-1	\$ 64.30	\$ -		SIDEWINDER	\$ 5.00	\$ -	
		\$ -	\$ -			\$ -	\$ -	
		\$ -	\$ -			\$ -	\$ -	
		\$ -	\$ -			\$ -	\$ -	
		\$ -	\$ -			\$ -	\$ -	
		\$ -	\$ -			\$ -	\$ -	
		\$ -	\$ -			\$ -	\$ -	
TOTAL OF EACH COLUMN EQUIPMENT COST:				\$ -				
TOTAL COMBINED EQUIPMENT COLUMN COST-"A" & "B":					\$ -			

MATERIALS / SUBCONTRACTORS-DESCRIPTION <small>(All material, rental and subcontractor invoices must be attached to this Sales Order.)</small>							
SUB / SUPPLIER	INVOICE NUMBER	QUANTITY	DESCRIPTION	\$\$ VALUE	ROW \$\$ TOTAL		
					\$ -		\$ -
					\$ -		\$ -
					\$ -		\$ -
					\$ -		\$ -
					\$ -		\$ -
					\$ -		\$ -
					\$ -		\$ -
TOTAL OF ALL MATERIALS OR SUBCONTRACTORS:				\$			\$ -
COMBINED SUBTOTAL OF ALL PERSONNEL, EQUIPMENT & MATERIALS OR SUBCONTRACTORS:				\$			267.98
15% OVERHEAD MARKUP				\$			40.20
GRAND TOTAL OF ALL PERSONNEL, EQUIPMENT & MATERIALS OR SUBCONTRACTORS AND MARKUP:				\$			308.18

BY-W.R.F. EMPLOYEE:	Juan Poblano	W.R.F. JOB #	2022-20
OWNER / CLIENT REP. SIGNATURE		CLIENT REF. #:	

The above equipment is working under the renter's full direction and supervision. Renter shall indemnify W.R. Forde Associates against all claims, demands, costs, attorney fees and liability of every nature arising from injury to person or property or the economic interests of any party resulting from or alleged to result from renters operations, performance or nonperformance. Such indemnity shall extend to all claims, demands and liability arising from the activities of the renter. This indemnity agreement applies to claims, demands and liability for injuries occurring after completion of the rental agreement, as well as during the performance of this agreement and extends to claims of demands and liability for injuries contributed by the negligence or the other misconduct of W.R. Forde Associates, as long as the injury is alleged to be or is caused in part by the negligence or misconduct of Renter.

Work per E-Mail 2022-20 - WRF File #24
3/15/2024 7:22 AM



W.R. FORDE ASSOCIATES, INC.

984 HENSLEY STREET
RICHMOND, CALIFORNIA 94804
PHONE (510) 215-9338
FAX (510) 215-9867

2022-20 - WRF File #24

Summary table with columns: SOLD TO, DATE, SALES NO., WORK PERFORMED AT LOCATION / STATION, COMPLETE DESCRIPTION OF WORK PERFORMED, POSITION, PERSONNEL, TOTAL REG., O.T., D.T., O.T. RATE, TOTAL HOURS.

Main equipment cost table with columns: HOURS WORKED, EQUIPMENT, RATE, COLUMN "A" \$\$ TOTAL, HOURS WORKED, EQUIPMENT, RATE, COLUMN "B" \$\$ TOTAL.

TOTAL COMBINED EQUIPMENT COLUMN COST-"A" & "B": \$ 325.22

MATERIALS / SUBCONTRACTORS-DESCRIPTION

Table with columns: SUB / SUPPLIER, INVOICE NUMBER, QUANTITY, DESCRIPTION, \$\$ VALUE, ROW \$\$ TOTAL.

TOTAL OF ALL MATERIALS OR SUBCONTRACTORS: \$

COMBINED SUBTOTAL OF ALL PERSONNEL, EQUIPMENT & MATERIALS OR SUBCONTRACTORS: \$ 549.48

15% OVERHEAD MARKUP \$ 82.42

GRAND TOTAL OF ALL PERSONNEL, EQUIPMENT & MATERIALS OR SUBCONTRACTORS AND MARKUP: \$ 631.90

Table with columns: BY-W.R.F. EMPLOYEE, OWNER / CLIENT REP. SIGNATURE, W.R.F. JOB #, CLIENT REF. #.

The above equipment is working under the renter's full direction and supervision. Renter shall indemnify W.R. Forde Associates against all claims, demands, costs, attorney fees and liability of every nature arising from injury to person or property or the economic interests of any party resulting from or alleged to result from renter's operations, performance or nonperformance.



W.R. FORDE ASSOCIATES, INC.

984 HENSLEY STREET
RICHMOND, CALIFORNIA 94804
PHONE (510) 215-9338
FAX (510) 215-9867

2022-20 - WRF File #24

Table with 4 columns: SOLD TO, WORK PERFORMED AT LOCATION / STATION, COMPLETE DESCRIPTION OF WORK PERFORMED, DATE, SALES NO. Includes details for Amtz Builders, Claremont Middle School, Oakland, CA, and work description: Grade Under Canopy at Pavers, Grade Along Building.

Main equipment cost table with 8 columns: HOURS WORKED, EQUIPMENT, RATE, COLUMN "A" \$\$ TOTAL, HOURS WORKED, EQUIPMENT, RATE, COLUMN "B" \$\$ TOTAL. Lists various equipment like BACKHOE, EXCAVATOR, DOZER, etc.

TOTAL OF EACH COLUMN EQUIPMENT COST: \$ -

TOTAL COMBINED EQUIPMENT COLUMN COST-"A" & "B": \$ -

MATERIALS / SUBCONTRACTORS-DESCRIPTION table with 6 columns: SUB / SUPPLIER, INVOICE NUMBER, QUANTITY, DESCRIPTION, \$\$ VALUE, ROW \$\$ TOTAL. Includes summary rows for TOTAL OF ALL MATERIALS OR SUBCONTRACTORS, COMBINED SUBTOTAL, 15% OVERHEAD MARKUP, and GRAND TOTAL.

BY-W.R.F. EMPLOYEE: Ramon Ramirez, W.R.F. JOB #: 2022-20, OWNER / CLIENT REP. SIGNATURE, CLIENT REF. #:

The above equipment is working under the renter's full direction and supervision. Renter shall indemnify W.R. Forde Associates against all claims, demands, costs, attorney fees and liability of every nature arising from injury to person or property or the economic interests of any party resulting from or alleged to result from renter's operations, performance or nonperformance.



984 HENSLEY STREET
 RICHMOND, CA 94804
 PHONE (510) 215-9338
 FAX (510) 215-9867

FIELD SALES ORDER

SOLD TO:	Arntz	WORK DATE:	7/6/23
SPECIFIC ONSITE LOCATION / STATION:	Claremont M School		
COMPLETE DESCRIPTION OF WORK PERFORMED:			
grade under canopy grade est pavers, Grack Abaz Buildings			

POSITION	PERSONNEL	TOTAL WORK HOURS		
		REG	O.T.	D.T.
Superintendent:				
Foreman:	Ramon (3)	1	2	
Operator:	Frank (3)	1	2	
Laborer:	JOSE A. (3) Alfredo 3	2	4	
Teamster:				
Other:				
Other:				

EQUIPMENT	HOURS	EQUIPMENT	HOURS	EQUIPMENT	HOURS
BACKHOE, # _____		TRANSPORT TRUCK		FORKLIFT, # _____	
SKIP LOADER, # _____		SUPER DUMP		BLADE, # _____	
ROAD GRADER		BOBTAIL		TRASH PUMP, # _____	
RUBBER TIRE LOADER, # _____		WORK TRUCK W/TOOLS	3 hrs	CCTV CAMERA + REEL	
TRACK LOADER, # _____		WATER TRUCK		PORTABLE GENERATOR	
DOZER, # _____		AC GRINDER		LASER	
EXCAVATOR, # 5035	3 hrs	PAVER		SIDEWINDER	
ROLLER, # _____		AIR COMPRESSOR W/TOOLS		SHORING	
COMPACTOR, # _____		WALK BEHIND WET SAW W/BLADE			
		Skts teer	3 hrs		

(All materials, rentals and subcontractor field invoices must be attached to this Sales Order.)

SUB/SUPPLIER	SUPPLIER TAG NUMBER	QUANTITY	DESCRIPTION
D.G.N. Trucking	0953	2 hrs	1 class D

BY-W.R.F. EMPLOYEE:	Ramon Ramirez	W.R.F. JOB#:	2020-22
OWNER/CLIENT SIGNATURE:		CLIENT REF#:	

The above equipment is working under the renter's full direction and supervision. Renter shall indemnify W. R. Forde Associates, Inc. against all claims, demands, costs, attorney fees and liability of every nature arising from injury to person or property or the economic interests of any party resulting from or alleged to result from renter's operations, performance or nonperformance. Such indemnity shall extend to all claims, demands and liability arising from the activities of the renter. This indemnity agreement applies to claims, demands and liability for injuries occurring after completion of the rental agreement, as well as during the performance of this agreement and extends to claims demands and liability for injury contributed by the negligence or the other misconduct of W. R. Forde Associates, Inc., as long as the injury is alleged to be or is caused in part by the negligence or misconduct of renter.

WRF File # _____	TAG# 01235
-------------------------	-------------------



984 HENSLEY STREET
 RICHMOND, CA 94804
 PHONE (510) 215-9338
 FAX (510) 215-9867

FIELD SALES ORDER

SOLD TO:	<i>Amtz</i>	WORK DATE:	<i>7/11/23</i>
SPECIFIC ONSITE LOCATION / STATION:	<i>Grade for Platwork</i>		
COMPLETE DESCRIPTION OF WORK PERFORMED:	<i>Grade for flat work (Claremont)</i>		

POSITION	PERSONNEL	TOTAL WORK HOURS		
		REG	O.T.	D.T.
Superintendent:				
Foreman:	<i>JUAN, P</i>		<i>2</i>	
Operator:	<i>NANCY WU, JOSE</i>		<i>2</i>	
Laborer:	<i>Alonso, Adrian, JOSE, JOSE P</i>		<i>8</i>	
Teamster:				
Other:				
Other:				

EQUIPMENT	HOURS	EQUIPMENT	HOURS	EQUIPMENT	HOURS
BACKHOE, # _____		TRANSPORT TRUCK		FORKLIFT, # _____	
SKIP LOADER, # _____		SUPER DUMP		BLADE, # _____	
ROAD GRADER		BOBTAIL		TRASH PUMP, # _____	
RUBBER TIRE LOADER, # _____		WORK TRUCK W/TOOLS		CCTV CAMERA + REEL	
TRACK LOADER, # _____		WATER TRUCK		PORTABLE GENERATOR	
DOZER, # _____		AC GRINDER		LASER	
EXCAVATOR, # <i>60 EX</i>		PAVER		SIDEWINDER	
ROLLER, # _____		AIR COMPRESSOR W/TOOLS		SHORING	
COMPACTOR, # _____		WALK BEHIND WET SAW W/BLADE			

(All materials, rentals and subcontractor field invoices must be attached to this Sales Order.)

SUB/SUPPLIER	SUPPLIER TAG NUMBER	QUANTITY	DESCRIPTION

BY-W.R.F. EMPLOYEE:	<i>Juan M. Pedraza</i>	W.R.F. JOB#:	<i>2021-22</i>
OWNER/CLIENT SIGNATURE:		CLIENT REF#:	

The above equipment is working under the renter's full direction and supervision. Renter shall indemnify W. R. Forde Associates, Inc. against all claims, demands, costs, attorney fees and liability of every nature arising from injury to person or property or the economic interests of any party resulting from or alleged to result from renter's operations, performance or nonperformance. Such indemnity shall extend to all claims, demands and liability arising from the activities of the renter. This indemnity agreement applies to claims, demands and liability for injuries occurring after completion of the rental agreement, as well as during the performance of this agreement and extends to claims demands; and liability for injury contributed by the negligence or the other misconduct of W. R. Forde Associates, Inc., as long as the injury is alleged to be or is caused in part by the negligence or misconduct of renter.

WRF File # <i>28</i>	<i>VERIFIED T&M only - [Signature]</i>	TAG# 05930
----------------------	--	-------------------

OFFICE/PROCESSING



984 HENSLEY STREET
 RICHMOND, CA 94804
 PHONE (510) 215-9338
 FAX (510)215-9867

FIELD SALES ORDER

SOLD TO:	ARNTZ	WORK DATE:	7-12-23
SPECIFIC ONSITE LOCATION / STATION:	SITWORK ACCELERATION		

COMPLETE DESCRIPTION OF WORK PERFORMED:
WORKING OVERTIME ON CONTRACT WORK TO ACCELERATE SITWORK DELAYED BY UNFORESEEN (E) CONDITIONS

POSITION	PERSONNEL	TOTAL WORK HOURS		
		REG	O.T.	D.T.
Superintendent:				
Foeman:	JUAN P		2	
Operator:	JOSE N		2	
Laborer:	JOSE R, JOSE A, ADRIAN, ALONSO		8	
Teamster:				
Other:				
Other:				

EQUIPMENT	HOURS	EQUIPMENT	HOURS	EQUIPMENT	HOURS
BACKHOE, # _____		TRANSPORT TRUCK		FORKLIFT, # _____	
SKIP LOADER, # _____		SUPER DUMP		BLADE, # _____	
ROAD GRADER		BORTAIL		TRASH PUMP, # _____	
RUBBER TIRE LOADER, # _____		WORK TRUCK W/TOOLS x2	4	CCTV CAMERA + REEL	
TRACK LOADER, # _____		WATER TRUCK		PORTABLE GENERATOR	
DOZER, # _____		AC GRINDER		LASER	
EXCAVATOR, # MINI EX	2	PAVER		SIDEWINDER	
ROLLER, # _____		AIR COMPRESSOR W/TOOLS		SHORING	
COMPACTOR, # _____		WALK BEHIND WET SAW W/BLADE			
EXCAVATOR #35	2				

(All materials, rentals and subcontractor field invoices must be attached to this Sales Order.)

SUB/SUPPLIER	SUPPLIER TAG NUMBER	QUANTITY	DESCRIPTION

BY-W.R.F. EMPLOYEE:	Juan Pablos	W.R.F. JOB#:	2022-20
OWNER/CLIENT SIGNATURE:		CLIENT REF#:	

The above equipment is working under the renter's full direction and supervision. Renter shall indemnify W. R. Forde Associates, Inc. against all claims, demands, costs, attorney fees and liability of every nature arising from injury to person or property or the economic interests of any party resulting from or alleged to result from renter's operations, performance or nonperformance. Such indemnity shall extend to all claims, demands and liability arising from the activities of the renter. This indemnity agreement applies to claims, demands and liability for injuries occurring after completion of the rental agreement, as well as during the performance of this agreement and extends to claims demands and liability for injury contributed by the negligence or the other misconduct of W. R. Forde Associates, Inc., as long as the injury is alleged to be or is caused in part by the negligence or misconduct of renter.

WRF File # 24	REQUIRED TERM ONLY - SUP. BY (OR)	TAG# 05931
----------------------	--	-------------------

OFFICE/PROCESSING



984 HENSLEY STREET
 RICHMOND, CA 94804
 PHONE (510) 215-9338
 FAX (510) 215-9867

FIELD SALES ORDER

SOLD TO:	ARNTZ	WORK DATE:	7-13-23
SPECIFIC ONSITE LOCATION / STATION:	CLAREMONT		

COMPLETE DESCRIPTION OF WORK PERFORMED:
 REMAINING ONSITE TO ALLOW FOR ACCELERATION OF SITework
 DUE TO UNFORESEEN CONDITIONS.

POSITION	PERSONNEL	TOTAL WORK HOURS		
		REG	O.T.	D.T.
Superintendent:				
Foreman:	JUAN P		2	
Operator:	JOSE N		2	
Laborer:	ADRIAN A, ALONSO S, JOSE R, JOSE A		8	
Teamster:				
Other:				
Other:				

EQUIPMENT	HOURS	EQUIPMENT	HOURS	EQUIPMENT	HOURS
BACKHOE, # _____		TRANSPORT TRUCK		FORKLIFT, # _____	
SKIP LOADER, # 2086	2	SUPER DUMP		BLADE, # _____	
ROAD GRADER		BOBTAIL		TRASH PUMP, # _____	
RUBBER TIRE LOADER, # _____		WORK TRUCK W/TOOLS x2	4	CCTV CAMERA + REEL	
TRACK LOADER, # _____		WATER TRUCK		PORTABLE GENERATOR	
DOZER, # _____		AC GRINDER		LASER	
EXCAVATOR, # 35	2	PAVER		SIDEWINDER	
ROLLER, # _____		AIR COMPRESSOR W/TOOLS		SHORING	
COMPACTOR, # _____		WALK BEHIND WET SAW W/BLADE			

(All materials, rentals and subcontractor field invoices must be attached to this Sales Order.)

SUB/SUPPLIER	SUPPLIER TAG NUMBER	QUANTITY	DESCRIPTION

BY-W.R.F. EMPLOYEE:	Juan Roblan	W.R.F. JOB#:	2022-20
OWNER/CLIENT SIGNATURE:		CLIENT REF#:	

The above equipment is working under the renter's full direction and supervision. Renter shall indemnify W. R. Forde Associates, Inc. against all claims, demands, costs, attorney fees and liability of every nature arising from injury to person or property or the economic interests of any party resulting from or alleged to result from renter's operations, performance or nonperformance. Such indemnity shall extend to all claims, demands and liability arising from the activities of the renter. This indemnity agreement applies to claims, demands and liability for injuries occurring after completion of the rental agreement, as well as during the performance of this agreement and extends to claims demands and liability for injury contributed by the negligence or the other misconduct of W. R. Forde Associates, Inc., as long as the injury is alleged to be or is caused in part by the negligence or misconduct of renter.

WRF File # 24	VERIFIED TEAM ONLY - [Signature]	TAG# 01238
---------------	----------------------------------	------------

OFFICE/PROCESSING



984 HENSLEY STREET
 RICHMOND, CA 94804
 PHONE (510) 215-9338
 FAX (510)215-9867

FIELD SALES ORDER

SOLD TO:	<i>Arntz</i>	WORK DATE:	<i>7/14/23</i>
SPECIFIC ONSITE LOCATION / STATION:	<i>set boxes</i>		
COMPLETE DESCRIPTION OF WORK PERFORMED:	<i>Set boxes to grade fill planters</i>		

POSITION	PERSONNEL	TOTAL WORK HOURS		
		REG	O.T.	D.T.
Superintendent:				
Foreman:	<i>Juan P</i>		<i>2</i>	
Operator:	<i>Navawo Jose</i>		<i>2</i>	
Laborer:	<i>Alonso, Jose R, Jose P</i>		<i>6</i>	
Teamster:				
Other:				
Other:				

EQUIPMENT	HOURS	EQUIPMENT	HOURS	EQUIPMENT	HOURS
BACKHOE, # _____		TRANSPORT TRUCK		FORKLIFT, # _____	
SKIP LOADER, # _____		SUPER DUMP		BLADE, # _____	
ROAD GRADER		BOBTAIL		TRASH PUMP, # _____	
RUBBER TIRE LOADER, # <i>Dumper</i>	<i>2</i>	WORK TRUCK W/TOOLS	<i>2</i>	CCTV CAMERA + REEL	
TRACK LOADER, # _____		WATER TRUCK		PORTABLE GENERATOR	
DOZER, # _____		AC GRINDER		LASER	
EXCAVATOR, # <i>mini-exc</i>	<i>2</i>	PAVER		SIDEWINDER	
ROLLER, # _____		AIR COMPRESSOR W/TOOLS		SHORING	
COMPACTOR, # _____		WALK BEHIND WET SAW W/BLADE			

(All materials, rentals and subcontractor field invoices must be attached to this Sales Order.)

SUB/SUPPLIER	SUPPLIER TAG NUMBER	QUANTITY	DESCRIPTION

BY-W.R.F. EMPLOYEE:	<i>Juan Poblano</i>	W.R.F. JOB#:	<i>2021-22</i>
OWNER/CLIENT SIGNATURE:		CLIENT REF#:	

The above equipment is working under the renter's full direction and supervision. Renter shall indemnify W. R. Forde Associates, Inc. against all claims, demands, costs, attorney fees and liability of every nature arising from injury to person or property or the economic interests of any party resulting from or alleged to result from renter's operations, performance or nonperformance. Such indemnity shall extend to all claims, demands and liability arising from the activities of the renter. This indemnity agreement applies to claims, demands and liability for injuries occurring after completion of the rental agreement, as well as during the performance of this agreement and extends to claims demands and liability for injury contributed by the negligence or the other misconduct of W. R. Forde Associates, Inc., as long as the injury is alleged to be or is caused in part by the negligence or misconduct of renter.

WRF File # <i>24</i>	<i>Verified T&M only - Set B. S. (100)</i>	TAG# 01239
----------------------	--	-------------------

OFFICE/PROCESSING



984 HENSLEY STREET
 RICHMOND, CA 94804
 PHONE (510) 215-9338
 FAX (510)215-9867

FIELD SALES ORDER

SOLD TO:	Amtz Builders	WORK DATE:	7-18-23
SPECIFIC ONSITE LOCATION / STATION:	Claremont M.S.		
COMPLETE DESCRIPTION OF WORK PERFORMED:			
Site acceleration.			

POSITION	PERSONNEL	TOTAL WORK HOURS		
		REG	O.T.	D.T.
Superintendent:				
Foreman:	Jim P		2	
Operator:	Jose N		2	
Laborer:	Alonzo S, Adrian N, Jose R		6	
Teamster:				
Other:				
Other:				

EQUIPMENT	HOURS	EQUIPMENT	HOURS	EQUIPMENT	HOURS
BACKHOE, # _____		TRANSPORT TRUCK		FORKLIFT, # _____	
SKIP LOADER, # <u>2086</u>	2	SUPER DUMP		BLADE, # _____	
ROAD GRADER		BOBTAIL		TRASH PUMP, # _____	
RUBBER TIRE LOADER, # _____		WORK TRUCK W/TOOLS	2	CCTV CAMERA + REEL	
TRACK LOADER, # _____		WATER TRUCK		PORTABLE GENERATOR	
DOZER, # _____		AC GRINDER		LASER	
EXCAVATOR, # <u>35</u>	2	PAVER		SIDEWINDER	
ROLLER, # _____		AIR COMPRESSOR W/TOOLS		SHORING	
COMPACTOR, # _____		WALK BEHIND WET SAW W/BLADE			

(All materials, rentals and subcontractor field invoices must be attached to this Sales Order.)

SUB/SUPPLIER	SUPPLIER TAG NUMBER	QUANTITY	DESCRIPTION

BY-W.R.F. EMPLOYEE:	Juan Pablos	W.R.F. JOB#:	2022-20
OWNER/CLIENT SIGNATURE:		CLIENT REF#:	

The above equipment is working under the renter's full direction and supervision. Renter shall indemnify W. R. Forde Associates, Inc. against all claims, demands, costs, attorney fees and liability of every nature arising from injury to person or property or the economic interests of any party resulting from or alleged to result from renter's operations, performance or nonperformance. Such indemnity shall extend to all claims, demands and liability arising from the activities of the renter. This indemnity agreement applies to claims, demands and liability for injuries occurring after completion of the rental agreement, as well as during the performance of this agreement and extends to claims demands and liability for injury contributed by the negligence or the other misconduct of W. R. Forde Associates, Inc., as long as the injury is alleged to be or is caused in part by the negligence or misconduct of renter.

WRF File # <u>24</u>	VERIFIED T&M ONLY - SEP 19, 2023 (100)	TAG# 01083
-----------------------------	--	--

OFFICE/PROCESSING



984 HENSLEY STREET
 RICHMOND, CA 94804
 PHONE (510) 215-9338
 FAX (510)215-9867

FIELD SALES ORDER

SOLD TO:	Arntz Builders	WORK DATE:	7-19-23	
SPECIFIC ONSITE LOCATION / STATION:				
COMPLETE DESCRIPTION OF WORK PERFORMED:	Site acceleration			
POSITION	PERSONNEL	TOTAL WORK HOURS		
		REG	O.T.	D.T.
Superintendent:				
Foremen:	Juan P		2	
Operator:	Jose N		2	
Laborer:	Jose R, Alonso S, Adrian N		6	
Teamster:				
Other:				
Other:				

EQUIPMENT	HOURS	EQUIPMENT	HOURS	EQUIPMENT	HOURS
BACKHOE, # _____		TRANSPORT TRUCK		FORKLIFT, # _____	
SKIP LOADER, # _____		SUPER DUMP		BLADE, # _____	
ROAD GRADER		BOBTAIL		TRASH PUMP, # _____	
RUBBER TIRE LOADER, # _____		WORK TRUCK W/TOOLS	4	CCTV CAMERA + REEL	
TRACK LOADER, # _____		WATER TRUCK		PORTABLE GENERATOR	
DOZER, # _____		AC GRINDER		LASER	
EXCAVATOR, # 50	2	PAVER		SIDEWINDER	
ROLLER, # _____		AIR COMPRESSOR W/TOOLS		SHORING	
COMPACTOR, # _____		WALK BEHIND WET SAW W/BLADE			

(All materials, rentals and subcontractor field invoices must be attached to this Sales Order.)

SUB/SUPPLIER	SUPPLIER TAG NUMBER	QUANTITY	DESCRIPTION

BY-W.R.F. EMPLOYEE:	Juan Pableno	W.R.F. JOB#:	2022-20
OWNER/CLIENT SIGNATURE:		CLIENT REF#:	

The above equipment is working under the renter's full direction and supervision. Renter shall indemnify W. R. Forde Associates, Inc. against all claims, demands, costs, attorney fees and liability of every nature arising from injury to person or property or the economic interests of any party resulting from or alleged to result from renter's operations, performance or nonperformance. Such indemnity shall extend to all claims, demands and liability arising from the activities of the renter. This indemnity agreement applies to claims, demands and liability for injuries occurring after completion of the rental agreement, as well as during the performance of this agreement and extends to claims demands and liability for injury contributed by the negligence or the other misconduct of W. R. Forde Associates, Inc., as long as the injury is alleged to be or is caused in part by the negligence or misconduct of renter.

WRF File # 25	VERIFIED TAG ONLY - [Signature]	TAG# 01084
----------------------	--	-------------------

OFFICE/PROCESSING

Thank you,
Dave Arntz
Arntz Builders, Inc.
431 Payran Street
Petaluma, CA 94952
(707) 835-2900
(707) 835-2994 Fax
www.arntzbuilders.com



From: Curtis Freeze <curtis.freeze@sixthdimensionpm.com>
Sent: Thursday, June 15, 2023 10:37 AM
To: David Arntz <DArntz@arntzbuilders.com>; Robert Arntz <RtArntz@arntzbuilders.com>; Cole Azamar <Cole@arntzbuilders.com>; Jake Hankins <Jake@arntzbuilders.com>
Cc: steve@kdigrp.com; smeek@smarchitecture.com; Brittany Dhawan <Brittany@studio144architects.com>; Chastity Henderson <chastity.henderson@ousd.org>
Subject: Re: Overtime

Are you speaking to overtime or premium time?
Over time is anything over 40 hours during the week
Premium Time is Saturday, Sunday or Holiday

Curtis

From: David Arntz <DArntz@arntzbuilders.com>
Sent: Thursday, June 15, 2023 10:17 AM
To: Curtis Freeze <curtis.freeze@sixthdimensionpm.com>; Robert Arntz <RtArntz@arntzbuilders.com>; Cole Azamar <Cole@arntzbuilders.com>; Jake Hankins <Jake@arntzbuilders.com>
Cc: steve@kdigrp.com <steve@kdigrp.com>; smeek@smarchitecture.com <smeek@smarchitecture.com>; Brittany Dhawan <Brittany@studio144architects.com>; Chastity Henderson <chastity.henderson@ousd.org>
Subject: RE: Overtime

Curtis,

I don't understand the logic behind this, if this is change order work or contract work that has been delayed by unforeseen circumstances, why shouldn't the contractor be able to supplement crews on weekends to catch up? We have a lot of work this summer to complete and the subcontractors may elect to avoid OT with this constraint. I hope it doesn't impact a timely completion.

WR Forde – grading and paving AC (contract work), electrical trench, gas line, water line, footing and slab demo, striping (contract work)

Tulum – Conduit routing in the new trench, pulling wire through new conduits

Arntz – Site concrete work, basketball hoop footing and standards, site benches (contract work)

Please let me know if this is acceptable.

Thank you,

Robert Arntz
Arntz Builders, Inc
(707) 835-2900

From: Curtis Freeze <curtis.freeze@sixthdimensionpm.com>

Sent: Thursday, June 15, 2023 9:05 AM

To: Robert Arntz <RtArntz@arntzbuilders.com>; Cole Azamar <Cole@arntzbuilders.com>; Jake Hankins <Jake@arntzbuilders.com>

Cc: steve@kdigrp.com; smeek@smarchitecture.com; Brittany Dhawan <Brittany@studio144architects.com>; Chastity Henderson <chastity.henderson@ousd.org>

Subject: Overtime

Robert, you are good to go on overtime, be it contract or change orders, the time sheets must be accurate and signed off daily by the IOR, please copy me as I will be tracking as well.

Thank you,

Curtis Freeze
Project Manager
Sixth Dimension PM

Chastity Henderson

From: Samantha Toscanelli <Samantha@arntzbuilders.com>
Sent: Tuesday, July 9, 2024 12:12 PM
To: Chastity Henderson
Cc: David Arntz; Robert Arntz; Emiliano Vinuya
Subject: [EXTERNAL] FW: Claremont PCO 75 - REVIEW NEEDED
Attachments: Claremont MPR CCR#75.1 Site Work Acc.pdf; Claremont - PCO 75.1 - Site Work Acceleration.pdf

Importance: High

Chastity,

Below please find WR Forde's response to Emil's comments.
Please have Emil's review. We would like to close this one out this week.

Thank You!

Samantha Toscanelli
Assistant Project Manager
Arntz Builders Inc.
(707) 835-2900



From: Sean McIntosh <sean@wrforde.net>
Sent: Tuesday, July 9, 2024 12:08 PM
To: Samantha Toscanelli <Samantha@arntzbuilders.com>
Cc: Candace Clapp <candace@wrforde.net>; Robert Arntz <RtArntz@arntzbuilders.com>
Subject: RE: Claremont PCO 75 - REVIEW NEEDED

Samantha,

The only tag that has equipment included was a tag in which we were performing work outside of our contract scope. The equipment is justified on that tag.

Thank you and best regards,

OAKLAND UNIFIED SCHOOL DISTRICT
CLAREMONT MS MULTI-PURPOSE & KITCHEN BUILDING
PROJ # 15127
CCR#75.1 ABI FILE 75 - SITE WORK ACCELERATION

To: Mike Torres/CM
From: Emil Vinuya, PE/Chief Cost Estimator
Date: 9-Jul-24

General Comments:

1 GENERAL CONTRACTOR: ARNTZ BUILDERS, INC.

Labor manhours based on IOR-signed T&M Tags submitted. OT premium rates for various trades used by GC/ABI appear reasonable.

2 SUBCONTRACTOR: WR FORDE

Labor manhours based on IOR-signed T&M Tags submitted. OT premium rates for various trades used by Sub appear reasonable.

3 GENERAL CONTRACTOR's COST PROPOSALS \$ 21,446.67

ESTIMATED CONSTRUCTION COST FOR CCR#75.1 \$ 21,446.67

Detailed Estimate

CLAREMONT MS MULTI-PURPOSE & KITCHEN BUILDING											
										Date: _____	
No.	CCR#75.1	No. of Units	Per	M.H. Per Unit	M. H. Total	LABOR COST		MATERIAL COST		EQUIPT. COST	
						Cost Per M. H.	Total Cost	Unit Cost	Total Cost	Unit Cost	Total Cost
SUBCONTRACTOR		#REF!									
Project Description:		#REF!									
1	SCOPE OF WORK:										
2	Site work acceleration due to										
3	delay (unforeseen conditions)										
4	MATERIALS										
5	Not Used	N/A	LF	0.000	0.00			\$ -	\$ -		
6											
7											
8	LABOR:	Carp/FM		Carp/JM		Labor/JM		TOTAL			
9	6/15/2023	2.00	Hrs	0.00		0.00		2.00	Thurs		
10	6/16/2023	2.00						2.00	Fri		
11	6/17/2023	8.00						8.00	Sat		
12	6/19/2023	2.00						2.00	Mon		
13	6/20/2023	2.00		6.00		2.00		10.00	Tue		
14	6/22/2023	2.00		6.00		1.00		9.00	Thurs		
15	6/22/2023	2.00						2.00	Thurs		
16	6/23/2023	2.00						2.00	Fri		
17	6/24/2023	8.00						8.00	Sat		
18	6/25/2023	2.00						2.00	Mon		
19	6/27/2023	2.00						2.00	Tues		
20	6/28/2023	2.00						2.00	Wed		
21	6/29/2023	2.00						2.00	Thurs		
22	7/1/2023	8.00						8.00	Sat		
23	7/5/2023	2.00						2.00	Wed		
24	7/6/2023	2.00						2.00	Thurs		
25	7/7/2023	2.00						2.00	Fri		
26	7/8/2023	8.00		24.00		40.00		72.00	Sat		
27	7/10/2023	2.00						2.00	Mon		
28	7/11/2023	2.00						2.00	Tues		
29	7/12/2023	2.00						2.00	Wed		
30	7/13/2023	2.00						2.00	Thurs		
31	7/14/2023			8.00				8.00	Fri		
32	7/15/2023	8.00		8.00		48.00		64.00	Sat		
33	7/17/2023	2.00				6.00		8.00	Mon		
34	7/18/2023	2.00		7.00		2.00		11.00	Tues		
35	7/19/2023	2.00		8.00		10.00		20.00	Wed		
36	7/20/2023	2.00		9.00		8.00		19.00	Thurs		
37	7/21/2023	2.00		4.00		12.00		18.00	Fri		
38	7/22/2023	8.00		32.00		64.00		104.00	Sat		
39	7/24/2023	2.00		4.00		14.00		20.00	Mon		
40	7/25/2023	2.00		0.00		10.00		12.00	Fri		
41	7/26/2023	2.00		6.00		20.00		28.00	Wed		
42	7/31/2023	0.00		2.50		0.00		2.50	Mon		
43	8/1/2023	0.00		2.50		0.00		2.50	Tues		
44	8/2/2023	2.00						2.00	Wed		
45	8/3/2023	2.00						2.00	Thurs		
46	8/5/2024	8.00						8.00	Sat		
47	8/7/2023	0.00		2.00		0.00		2.00	Mon		
48	8/8/2023	0.00		2.50		0.00		2.50	Tues		
49	8/9/2023			2.00				2.00	Wed		
50	8/10/2023			2.00				2.00	Thurs		
51	8/11/2023			2.00				2.00	Fri		
52	8/12/2023	5.00						5.00	Sat		
54	TOTAL	119.00		117.50		241.00		477.50			
55											
	Carpenter/FM	1.00	LS	119.00	119.00	\$ 45.86	\$ 5,457.34				
	Carpenter/JM	1.00	LS	117.50	117.50	\$ 34.74	\$ 4,081.95				
	Laborer/JM	1.00	LS	241.00	241.00	\$ 20.85	\$ 5,024.85				
					477.50						
56	EQUIPMENT										
57	Not used	1.00	EA						\$ -	\$ -	
58											
59											
60											
61	SHEET TOTALS							\$14,564.14			\$ -

Detailed Estimate

CLAREMONT MS MULTI-PURPOSE & KITCHEN BUILDING											
										Date: _____	
No.	CCR#75.1	No. of Units	Per	M.H. Per Unit	M. H. Total	LABOR COST		MATERIAL COST		EQUIPT. COST	
						Cost Per M. H.	Total Cost	Unit Cost	Total Cost	Unit Cost	Total Cost
SUBCONTRACTOR		WR FORDE									
Project Description:		ABI FILE 75 - SITE WORK ACCELERATION									
1	SCOPE OF WORK:										
2	Site work acceleration due to										
3	delay (unforseen conditions)										
4	MATERIALS										
5	Not Used	N/A	LF	0.000	0.00			\$ -	\$ -		
6											
7											
8	LABOR:	OE/FM		OE/JM		Labor/JM		TOTAL	TAG		
9	6/19/2023	2.00		6.00		8.00		16.00	01068		
10	6/20/2023	0.00		0.00		0.00		0.00	01069		
11	6/21/2023	2.00		4.00		6.00		12.00	01070		
12	6/22/2023	2.00		4.00		6.00		12.00	01071		
13	6/23/2023	2.00		2.00		6.00		10.00	01073		
14	6/26/2023	2.00		2.00		4.00		8.00	10075		
15	7/6/2023	2.00		2.00		4.00		8.00	01235		
16	7/11/2023	2.00		2.00		8.00		12.00	05930		
17	7/12/2023	2.00		2.00		8.00		12.00	05931		
18	7/13/2023	2.00		2.00		8.00		12.00	01238		
19	7/14/2023	2.00		2.00		6.00		10.00	01239		
20	7/18/2023	2.00		2.00		6.00		10.00	01083		
21	7/19/2023	2.00		2.00		6.00		10.00	01084		
22	TOTAL	24.00		32.00		76.00		132.00	132	Check	
23											
24	Operating Engineer/FM	1.00	LS	24.00	24.00	\$ 35.62	\$ 854.88				
25	Operating Engineer/JM	1.00	LS	32.00	32.00	\$ 32.79	\$ 1,049.28				
26	Laborer/JM	1.00	LS	76.00	76.00	\$ 21.86	\$ 1,661.36				
27				132.00							
28											
29	EQUIPMENT										
30	Excavator, Mini	1.00	EA	4.00	4.00			\$ 49.49	\$ 197.96		
31	Truck Work	1.00	EA	2.00	2.00			\$ 63.63	\$ 127.26		
32											
33											
34	SHEET TOTALS						\$3,565.52			\$ 325.22	

OAKLAND UNIFIED SCHOOL DISTRICT

Division of Facilities Planning and Management • 955 High Street Oakland, California 94601 • Phone 510/535-2728 • Fax 510/535-7040

(Proposed Change Order) No. 4

PROJECT: Claremont Middle School MPR & Kitchen Project

DATE: OCTOBER 30, 2024

OWNER: OAKLAND UNIFIED SCHOOL DISTRICT

DSA FILE NO.: 01-119337

CONTRACTOR: ARNTZ BUILDERS INC.

DSA APP NO.: 01-119337

431 Payran

OUSD PROJECT #: 15127

Petaluma, CA 94952

PROJECT MANAGER: JaQuan Cornish

Contractor hereby submits this Change Order Request ("COR") pursuant to the contract documents, including but not limited to General Conditions sections 4.5.1, 4.5.2, 7.6, 7.7, 8.4.1, and 8.4.2.

DESCRIPTION OF PROPOSED CHANGES IN WORK (specifically refer to attached pages or incorporated documents): **PCO 97 – Existing RWL Re-Route (Unforeseen):** An existing pipe was found damaged while excavating for the new electrical trench. It was found this line was a RWL serving the high roof of Building B. The line was rerouted per RFI 309 direction.

OTHER PROPOSED CHANGES TO THE CONTRACT:

PCOs: #27, #58, #75, #120, #128, #139, #143, #144 & #146

PROPOSED ADJUSTMENT TO CONTRACT PRICE: **\$7,424.40**

PROPOSED ADJUSTMENT TO CONTRACT TIME: 0 calendar days

REASON FOR REQUEST (check one or more):

- Unforeseen Conditions
- Direction by Government Agency
- Owner Requested
- Design Omission
- Design Error
- Other: _____

OAKLAND UNIFIED SCHOOL DISTRICT

Division of Facilities Planning and Management • 955 High Street Oakland, California 94601 • Phone 510/535-2728 • Fax 510/535-7040

CERTIFICATION

I, Robert Arntz [name of declarant], declare the following:

Arntz Builders Inc. [Contractor company name] has contracted with Oakland Unified School District [public entity name] for the Claremont Middle School MPR & Kitchen Contract ("Contract"). Arntz Builders Inc. [Contractor company name] authorized me to prepare the attached Change Order Request ("COR") for money and/or time extension for Oakland Unified School District [public entity name] regarding this Contract (such COR being dated October 30, 2024, and entitled Change Order 1 and requesting \$2,153.35 and/or 0 additional days), and I prepared the attached COR. I am the most knowledgeable person at Arntz Builders Inc. [Contractor company name] regarding this COR.

The attached COR complies with all laws applicable to submission of a COR, including but not limited to California Penal Code section 72, Government Code sections 12650 et seq. (False Claims Act), and Business and Professions Code sections 17200 et seq. (Unfair Business Practices Act). I am aware that submission or certification of false claims, or other claims that violate law or the Contract, may lead to fines, imprisonment, and/or other serious legal consequences for myself or Arntz Builders [Contractor company name].

The attached COR does not breach the Contract, is not a false claim, does not violate any applicable law, satisfies all provisions of the Contract applicable to submission of the COR, only contains truthful and accurate supporting data, and only requests money and/or time extensions that accurately reflect the adjustments to money and time for which I believe that Oakland Unified School District [public entity name] is responsible under its Contract with Arntz Builders Inc. [Contractor company name].

While preparing this declaration and COR I consulted with others (including attorneys, consultants, or others who work for Arntz Builders Inc. [Contractor company name]) when necessary to ensure that the statements were true and correct.

Contractor understands and agrees that any COR submitted without this certification does not meet the terms of the Contract Documents; that Owner, or Owner's representatives, may reject the COR on that basis; and that unless Contractor properly and timely files the COR with the certification, Contractor cannot further pursue the COR in any forum and all rights to additional money or time for the issues covered by the COR are waived due to a condition precedent not having been satisfied.

I declare under the penalty of perjury under the laws of the State of California that the foregoing is true and correct. Executed October 30, 2024, at Oakland, California.

 [signature]

Robert Arntz [name of declarant]



Arntz Builders, Inc.

431 Payran St, Petaluma CA 94952 License No. 856393 T (707) 835-2900 F (707) 835-2993 www.arntzbuilders.com

Date: 7/17/23

Project Name: 2205 Claremont MS MPR & Kitchen

Generating Document: RFI 309R1

Arntz File #: 097

Arntz File Title: Existing RWL Re-Route

NOTIFICATION OF EXTRA:

The above referenced issue constitutes a changed condition resulting in extra work and extra costs. This condition will impact the project schedule.

Scope Change: While excavation for the new electrical trench took place, an existing pipe was found that was shattered and had roots in it. It was found this line is a RWL that serves the high roof of Building B. RFI 309 response gives direction to reroute this line.

Location: Building B



Arntz Builders, Inc.

431 Payran St, Petaluma CA 94952 License No. 856393 T (707) 835-2900 F (707) 835-2993 www.arntzbuilders.com

July 11, 2024

Oakland Unified School District
1000 Broadway, Ste 300
Oakland, CA 94607

Subject **Claremont MS New Multi-Purpose and Kitchen**
File No. 97.1 Existing RWL Re-Route

Good Afternoon,

While excavation for the new electrical trench took place, an existing pipe was found that was shattered and had roots in it. It was found this line is a RWL that serves the high roof of Building B. RFI 309 response gives direction to reroute this line.

Prime Work:

Labor		\$5,686.00
Material		\$770.00
Equipment/Other		\$0.00
Prime Subtotal		<u>\$6,456.00</u>
Mark-Up	15.0%	<u>\$968.40</u>

TOTAL QUOTE **\$7,424.40**

We reserve the right to submit a claim for an extension of time and for all related delay and inefficiency costs that may result due to the changed condition. The extent and amount will be determined at a later date when the full impact of changed condition can be evaluated and determined. All rights and remedies are reserved.

Sincerely,

ARNTZ BUILDERS

Robert Arntz
Project Manager

cc:
ST
enc

Time & Material Tag

Date: 07/11/2023
 Project Name: Claremont Middle School MPR & Kitchen
 Job #: 2205
 File #: RPT*309/CO #97
 Prime/Sub: _____



431 Payne St, Petaluma CA 94952
 License No. 256395
 T (707) 826-2900 F (707) 826-2990
 www.arvizbuilders.com

SCOPE:
 Investigate Downspout + gutter from upper roof of "B" Building. Cut Investigative hole in gutter soffit to expose drain connection. Walked Second Floor of "B" Building to locate possible access panel.

PERSONNEL - TRADE CLASSIFICATION AND HOURS

Name	Classification	Straight Time	OT	OT
Eamon Shree	CARP A		2	
Sean Phillips	CARP A		2	
			4	

MATERIALS - TYPE, QUANTITY, UNIT

MATERIAL	QUANTITY	UNIT

EQUIPMENT - TYPE, QUANTITY, UNIT

EQUIPMENT	QUANTITY	UNIT

Superior Signature _____

Authorized Signature _____

Date _____

TEAM ONLY SPT. 27
7-11-23

Time & Material Tag

Date: 8-5-23
 Project Name: Claremont Middle School MPR & Kitchen
 Job #: 2205
 File #: 97
 Prime/Sub: _____



431 Payton St, Fontana CA 92335
 License No. 855393
 T (707) 835-2800 F (707) 835-2993
 www.arnstbuilders.com

SCOPE: CUT OPEN WALL, RE-PATCHED SHEETROCK IN CLOSET WHERE (E) RNL WAS FOUND.

PERSONNEL - TRADE CLASSIFICATION AND HOURS:

Name	Classification	Straight Time	OT	DT
FRANCISCO BECERRA	LAB		4	
JESUS CALIXTRO	LAB		4	
			8	

MATERIALS - TYPE, QUANTITY, UNIT

MATERIAL	QUANTITY	UNIT

EQUIPMENT - TYPE, QUANTITY, UNIT

EQUIPMENT	QUANTITY	UNIT

Supervisor Signature _____

Authorized Signature _____

Date _____

VERAED T. MERRY *[Signature]* (102)

Time & Material Tag

Date: 10/9/23
 Project Name: Claremont Middle School MPR & Kitchen
 Job #: 2205
 File #: 97
 Prime/Sub: _____



431 Payran St, Fontana CA 92331
 License No. 056383
 T (767) 835-2900 F (767) 835-2998
 www.mrtidoll.com

SCOPE:
 Patched hole in Drywall and Plywood in "B" building Storage closet
 that was used to access RWL. Caulked edges of ply with fire caulking.

PERSONNEL - TRADE CLASSIFICATION AND HOURS:

Name	Classification	Straight Time	OT	DT
Oscar Salinas	CARP	4		
Jason Grewal	CARP	4		
		8		

MATERIALS - TYPE, QUANTITY, UNIT

MATERIAL	QUANTITY	UNIT
4x8 Fire Rated Plywood (3/4")		
3/8" x 2 1/2" Wood Screws		
Fire Caulk		
Multi tool blade		

EQUIPMENT - TYPE, QUANTITY, UNIT

EQUIPMENT	QUANTITY	UNIT

Supervisor Signature _____

Authorized Signature _____

VERIFIED T & M ONLY - [Signature] (10/9/23)

Date _____

PACE Supply Corp
P.O. Box 6407
Rohnert Park, CA 94927-6407



INVOICE

INVOICE DATE 08/07/23	INVOICE # 108808253	PAGE 1 of 1
DATE SHIPPED 08/07/23	CUSTOMER # 02154-00	

Branch Contact: 510-318-6900 FAX: 510-318-6784
Accounting & Credit: 855-306-5889

208 1 SP 0.630 E0200X 10367 D1 1610810055 S2 P8834185 0001:0001



ARNTZ BUILDERS
431 PAYRAN ST
PETALUMA CA 94952-5908

SHIP TO

ARNTZ BUILDERS
431 PAYRAN STREET
PETALUMA, CA 94952

CUSTOMER PURCHASE ORDER 2205	JOB NAME	SHIPPED VIA PICK UP	TERMS 2%10TH NET 25TH		TAXABLE ITEMS			
PART/DESCRIPTION			ORDER	SHIP	UNIT PRICE	EXTENSION		
NHP3 3 NO HUB CAST IRON PIPE			10	10	13.9601	139.60	Y	
NHBC3T 3 NO HUB TYLER COUPLING			2	2	5.4400	10.88	Y	
NHB143 3 NO HUB 1/4 BEND ▲ WARNING: The products you have purchased can expose you to chemicals and/or substances, which are known to the State of California to cause cancer and birth defects or other reproductive harm. For more information, go to www.P65Warnings.ca.gov			1	1	19.4000	19.40	Y	
Remit to: PACE Supply Corp P.O. Box 6407 Rohnert Park, CA 94927-6407 DUE TO THE SUSTAINED SURGE IN FUEL PRICES, EFFECTIVE IMMEDIATELY, WE ARE INCREASING OUR STANDARD DELIVERY FEE FROM \$10 TO \$15. LIMIT ONE FEE PER DAY, PER JOB.,								
THIS INVOICE IS SUBJECT TO ALL TERMS AND CONDITIONS ON THE FACE AND REVERSE			GROSS	TAX%	SALES TAX	SHIPPING & HANDLING	OTHER CHARGES	INVOICE TOTAL
			169.88	16.25%	17.41	0.00	0.00	187.29
TO VIEW ONLINE GO TO: https://paceupplybilltrust.com			USE THIS ENROLLMENT TOKEN	WVL GTB VWB	BILL TRUST ACCOUNT #	02154		

23 AUG 4 PM 12:28

A discount amount of 3.75 is offered if your payment via check, ACH or cash is received by 09/10/2023.

Material Signed for by: Nick N 08/07/23

★★★★★ 1 review(s)

**Zurn Z199 Downspout Nozzle, 2 inch Inlet,
SPECIFY CONNECTION
DRAIN-Z199-2**

Sale Price ~~\$665.00~~ **SALE \$409.99**

(Savings: \$255.01)

Typically ships in 1-2 Business Days



Order Options::

No-Hub (NH) ▼

Qty:

NON RETURNABLE

ADD TO CART

ADD TO WISH LIST

PRODUCT:

Zurn Z199 Downspout Nozzle, Cast Nickel Bronze. Inlet: 2 inch Pipe Size, No-Hub (NH) or Threaded (IP) Connection. Price/Each.



Arntz Builders, Inc.
 431 Payran Street
 Petaluma, California 94952
 P: +17078352900

**Project: 2205 Claremont Middle School Multi-Purpose Building
 & Kitchen**
 5750 College Ave
 Oakland , California 94618

RFI #309: Existing Pipe Found to be Dripping

Status	Open		
To	Jake Hankins (Arntz Builders, Inc.)	From	Jake Hankins (Arntz Builders, Inc.) 431 Payran Street Petaluma, California 94952
Date Initiated	Jun 6, 2023	Due Date	Jun 13, 2023
Location		Project Stage	Course of Construction
Cost Impact	TBD	Schedule Impact	TBD
Spec Section		Cost Code	
Drawing Number		Reference	
Linked Drawings	C1.0		
Received From			
Copies To	David Arntz (Arntz Builders, Inc.), Robert Arntz (Arntz Builders, Inc.), Cole Azamar (Arntz Builders, Inc.), Jake Hankins (Arntz Builders, Inc.), Nick Ivashkevich (Arntz Builders, Inc.)		

Activity

Question

Question from Jake Hankins Arntz Builders, Inc. on Tuesday, Jun 6, 2023 at 02:09 PM PDT

During excavation of the new electrical trench, a cast iron pipe was found near Building B that shattered as soon as we dug around it. It was also found that there is roots inside the pipe. It was assumed that this line was dead RWL line, however after the rain this afternoon, there was water dripping out of the end of this pipe. Please advise how to proceed with this line.

Attachments

[C1.0_ EXISTING CONDITIONS AND DEMOLITION PLAN Rev.0 \(1\).pdf](#), [EB2144B4-0C23-4C33-9C33-AAD617FB00AC.pdf](#)

Response by Susannah Meek, 6/6/2023:

Additional information is needed to formulate a response;

1) Why was it assumed to be a dead RWL? which roof would it be collecting water from?
 The RWL for the bldg B entry canopy exits at the column per keynote 05-15 on 6/A2.02

2) Does it appear the tree roots are from the recently demolished trees or from the redwood? Not sure tree roots says anything definitive about being in-use or abandoned except that at one time there was water in the pipe.

3) how far does the pipe extend under bldg B? where does the pipe go? Please see attached existing building information and mark on plan what seems most likely, and a response can be formulated.



S MEEK
ARCHITECTURE
3040 20th Street
San Francisco, CA 94110
415-643-5555

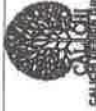

CALCON GROUP
CIVIL ENGINEERS
3040 20th Street
San Francisco, CA 94110
415-643-5555



CLAREMONT MIDDLE SCHOOL
5750 College Ave
Oakland CA 94618

Multi-Purpose Building & Kitchen

Oakland Unified School District

Issue Set / Revisions	Date
No. Description	
1 Design Development	08/29/20
2 50% Construction Doc	11/17/20
3 75% Construction Doc	12/22/20
4 DSA Submission	02/02/21
5 CR Re-submittal	08/27/21
6 DS1 Re-submittal	11/18/21

EXISTING CONDITIONS AND DEMOLITION PLAN

C1.0

11/18/2021
Issue Date
1517
CLINO Job No.

LEGEND

PROPERTY LINE	---
EXISTING LOT	---
EXISTING FOUNDATION	---
EXISTING CONCRETE	---
EXISTING MASONRY	---
EXISTING BRICK	---
EXISTING STONE	---
EXISTING WOOD	---
EXISTING METAL	---
EXISTING GLASS	---
EXISTING ASPHALT	---
EXISTING GRAVEL	---
EXISTING SOIL	---
EXISTING VEGETATION	---
EXISTING UTILITIES	---
EXISTING ELEC. CONDUIT	---
EXISTING WATER	---
EXISTING GAS	---
EXISTING SLOPE	---
EXISTING ELEVATION	---

DEMO KEY NOTES

- 1 DEMO ALL EXISTING CONSTRUCTION AND FOUNDATION TO GRADE.
- 2 DEMO ALL EXISTING CONSTRUCTION AND FOUNDATION TO GRADE.
- 3 DEMO ALL EXISTING CONSTRUCTION AND FOUNDATION TO GRADE.
- 4 DEMO ALL EXISTING CONSTRUCTION AND FOUNDATION TO GRADE.
- 5 DEMO ALL EXISTING CONSTRUCTION AND FOUNDATION TO GRADE.
- 6 DEMO ALL EXISTING CONSTRUCTION AND FOUNDATION TO GRADE.
- 7 DEMO ALL EXISTING CONSTRUCTION AND FOUNDATION TO GRADE.
- 8 DEMO ALL EXISTING CONSTRUCTION AND FOUNDATION TO GRADE.
- 9 DEMO ALL EXISTING CONSTRUCTION AND FOUNDATION TO GRADE.
- 10 DEMO ALL EXISTING CONSTRUCTION AND FOUNDATION TO GRADE.
- 11 DEMO ALL EXISTING CONSTRUCTION AND FOUNDATION TO GRADE.
- 12 DEMO ALL EXISTING CONSTRUCTION AND FOUNDATION TO GRADE.
- 13 DEMO ALL EXISTING CONSTRUCTION AND FOUNDATION TO GRADE.
- 14 DEMO ALL EXISTING CONSTRUCTION AND FOUNDATION TO GRADE.
- 15 DEMO ALL EXISTING CONSTRUCTION AND FOUNDATION TO GRADE.
- 16 DEMO ALL EXISTING CONSTRUCTION AND FOUNDATION TO GRADE.
- 17 DEMO ALL EXISTING CONSTRUCTION AND FOUNDATION TO GRADE.
- 18 DEMO ALL EXISTING CONSTRUCTION AND FOUNDATION TO GRADE.
- 19 DEMO ALL EXISTING CONSTRUCTION AND FOUNDATION TO GRADE.
- 20 DEMO ALL EXISTING CONSTRUCTION AND FOUNDATION TO GRADE.
- 21 DEMO ALL EXISTING CONSTRUCTION AND FOUNDATION TO GRADE.
- 22 DEMO ALL EXISTING CONSTRUCTION AND FOUNDATION TO GRADE.
- 23 DEMO ALL EXISTING CONSTRUCTION AND FOUNDATION TO GRADE.
- 24 DEMO ALL EXISTING CONSTRUCTION AND FOUNDATION TO GRADE.
- 25 DEMO ALL EXISTING CONSTRUCTION AND FOUNDATION TO GRADE.
- 26 DEMO ALL EXISTING CONSTRUCTION AND FOUNDATION TO GRADE.
- 27 DEMO ALL EXISTING CONSTRUCTION AND FOUNDATION TO GRADE.
- 28 DEMO ALL EXISTING CONSTRUCTION AND FOUNDATION TO GRADE.
- 29 DEMO ALL EXISTING CONSTRUCTION AND FOUNDATION TO GRADE.
- 30 DEMO ALL EXISTING CONSTRUCTION AND FOUNDATION TO GRADE.

DEMOLITION LEGEND

DEMOLITION OF EXISTING CONSTRUCTION	---
DEMOLITION OF EXISTING FOUNDATION	---
DEMOLITION OF EXISTING ROOF	---
DEMOLITION OF EXISTING INTERIORS	---
DEMOLITION OF EXISTING UTILITIES	---
DEMOLITION OF EXISTING LANDSCAPE	---
DEMOLITION OF EXISTING PAVEMENT	---
DEMOLITION OF EXISTING CURBS	---
DEMOLITION OF EXISTING DRIVEWAYS	---
DEMOLITION OF EXISTING SIDEWALKS	---
DEMOLITION OF EXISTING STAIRS	---
DEMOLITION OF EXISTING ELEVATORS	---
DEMOLITION OF EXISTING MECHANICAL	---
DEMOLITION OF EXISTING ELECTRICAL	---
DEMOLITION OF EXISTING TELEPHONE	---
DEMOLITION OF EXISTING CABLE	---
DEMOLITION OF EXISTING SLOPE	---
DEMOLITION OF EXISTING ELEVATION	---

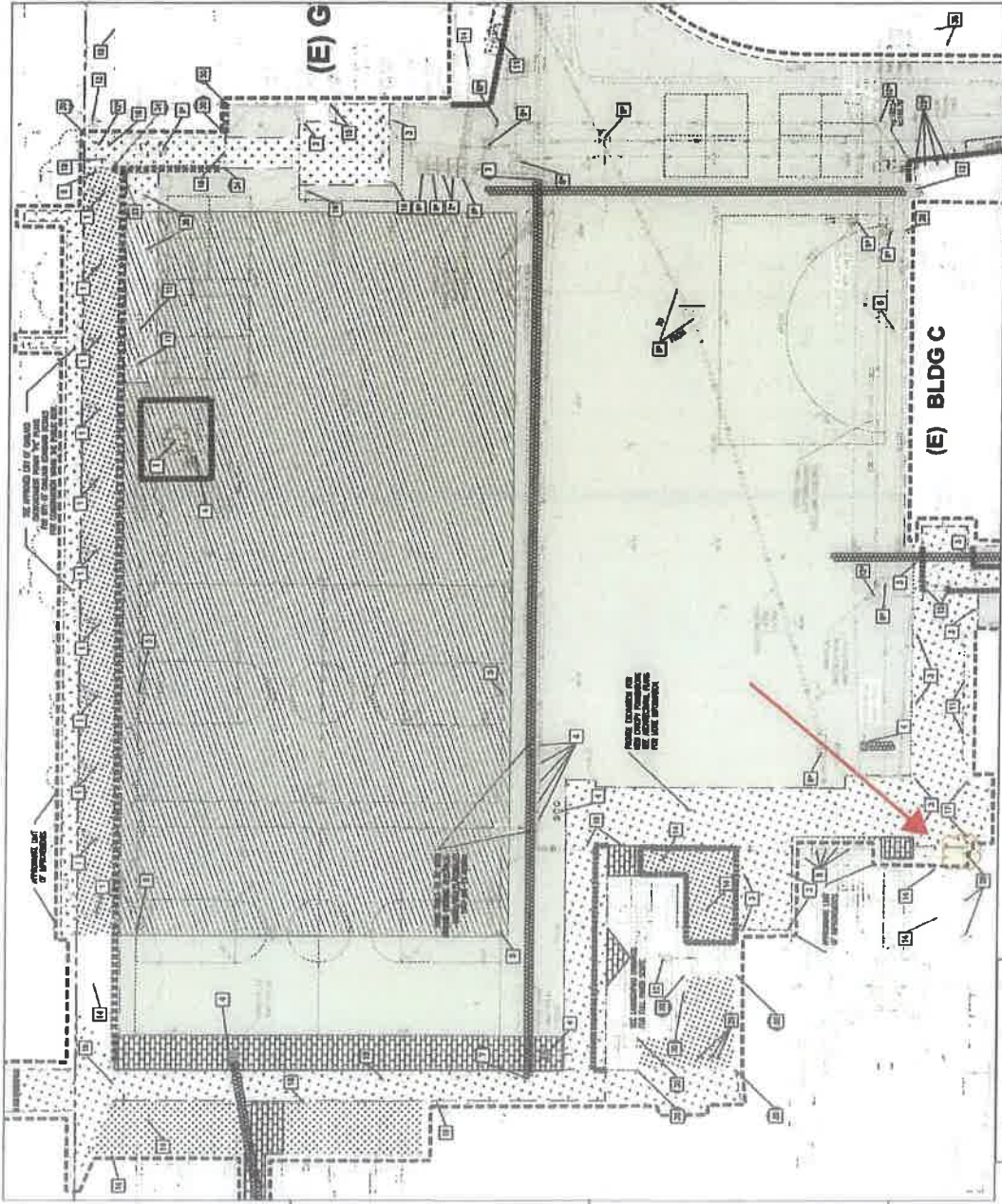

GENERAL NOTES:

1. SEE EXISTING CONDITIONS AND DEMOLITION PLAN FOR ALL EXISTING CONDITIONS.
2. ALL CONSTRUCTION SHALL BE IN ACCORDANCE WITH THE LATEST EDITIONS OF ALL APPLICABLE CODES AND REGULATIONS.
3. THE CONTRACTOR SHALL BE RESPONSIBLE FOR OBTAINING ALL NECESSARY PERMITS AND APPROVALS FROM THE LOCAL JURISDICTIONS.
4. THE CONTRACTOR SHALL BE RESPONSIBLE FOR PROTECTING ALL EXISTING UTILITIES AND STRUCTURES TO REMAIN.
5. ALL DEMOLITION SHALL BE IN ACCORDANCE WITH LOCAL, STATE, AND FEDERAL REGULATIONS.
6. THE CONTRACTOR SHALL BE RESPONSIBLE FOR DISPOSING OF ALL DEMOLITION DEBRIS IN ACCORDANCE WITH LOCAL, STATE, AND FEDERAL REGULATIONS.
7. THE CONTRACTOR SHALL BE RESPONSIBLE FOR RESTORING ALL EXISTING LANDSCAPE AND UTILITIES TO ORIGINAL OR BETTER CONDITION.
8. THE CONTRACTOR SHALL BE RESPONSIBLE FOR OBTAINING ALL NECESSARY PERMITS AND APPROVALS FROM THE LOCAL JURISDICTIONS.
9. THE CONTRACTOR SHALL BE RESPONSIBLE FOR PROTECTING ALL EXISTING UTILITIES AND STRUCTURES TO REMAIN.
10. ALL DEMOLITION SHALL BE IN ACCORDANCE WITH LOCAL, STATE, AND FEDERAL REGULATIONS.
11. THE CONTRACTOR SHALL BE RESPONSIBLE FOR DISPOSING OF ALL DEMOLITION DEBRIS IN ACCORDANCE WITH LOCAL, STATE, AND FEDERAL REGULATIONS.
12. THE CONTRACTOR SHALL BE RESPONSIBLE FOR RESTORING ALL EXISTING LANDSCAPE AND UTILITIES TO ORIGINAL OR BETTER CONDITION.
13. THE CONTRACTOR SHALL BE RESPONSIBLE FOR OBTAINING ALL NECESSARY PERMITS AND APPROVALS FROM THE LOCAL JURISDICTIONS.
14. THE CONTRACTOR SHALL BE RESPONSIBLE FOR PROTECTING ALL EXISTING UTILITIES AND STRUCTURES TO REMAIN.
15. ALL DEMOLITION SHALL BE IN ACCORDANCE WITH LOCAL, STATE, AND FEDERAL REGULATIONS.
16. THE CONTRACTOR SHALL BE RESPONSIBLE FOR DISPOSING OF ALL DEMOLITION DEBRIS IN ACCORDANCE WITH LOCAL, STATE, AND FEDERAL REGULATIONS.
17. THE CONTRACTOR SHALL BE RESPONSIBLE FOR RESTORING ALL EXISTING LANDSCAPE AND UTILITIES TO ORIGINAL OR BETTER CONDITION.
18. THE CONTRACTOR SHALL BE RESPONSIBLE FOR OBTAINING ALL NECESSARY PERMITS AND APPROVALS FROM THE LOCAL JURISDICTIONS.
19. THE CONTRACTOR SHALL BE RESPONSIBLE FOR PROTECTING ALL EXISTING UTILITIES AND STRUCTURES TO REMAIN.
20. ALL DEMOLITION SHALL BE IN ACCORDANCE WITH LOCAL, STATE, AND FEDERAL REGULATIONS.

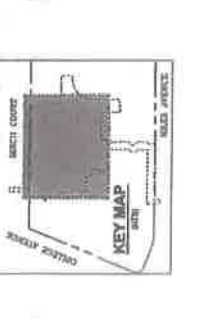

OAKLAND UNIFIED SCHOOL DISTRICT
CLAREMONT MS MULTI-PUROSE & KITCHEN BUILDING
PROJ # 15127
CCR#97.1 ABI FILE 97 - EXISTING RWL RE-ROUTE (T&M)

To: C. HENDERSON/POJ ENGR
From: E. Vinuya, PE/Chief Cost Estimator
Date: 11-Jul-24

General Comments:

1 GENERAL CONTRACTOR: ARNTZ BUILDERS, INC.

Manhours based on IOR-signed T&M tags. Labor hourly rates per approved rates.

Materials prices are per submitted Invoices.

2 GENERAL CONTRACTOR'S COST PROPOSALS \$ **7,424.40**

ESTIMATED CONSTRUCTION COST FOR CCR#97.1 \$ **7,424.40**

Detailed Estimate

CLAREMONT MS MULTI-PUROSE & KITCHEN BUILDING										
										Date: 7/11/2024
No.	CCR#97.1	LABOR COST					MATERIAL COST		EQUIPT. COST	
		No. of Units	Per	M.H. Per Unit	M. H. Total	Cost Per M. H.	Total Cost	Unit Cost	Total Cost	Unit Cost
GEN CONTRACTOR		ARNTZ BUILDERS INC.								
Project Description:		ABI FILE 97 - EXISTING RWL RE-ROUTE (T&M)								
1	SCOPE OF WORK:									
2	Re-route RWL									
3										
4										
5	MATERIALS									
6	Fire Treated Plywood	1.00	Sheet	0.000	0.00		\$ 121.44	\$ 121.44		
7	Pace Supply Invoice #108808253 - CI Pipe	1.00	LS	0.000	0.00		\$ 169.88	\$ 169.88		
8	Zurn Downspout Nozzles	1.00	EA	0.000	0.00		\$ 343.59	\$ 343.59		
9	Blades	2.00	EA	0.000	0.00		\$ 31.97	\$ 63.94		
10										
11										
12										
13										
14										
15	LABOR:									
16	Carpenter/JM, Reg	1.00	EA	40.00	40.00	\$ 108.45	\$ 4,338.00			
17	Carpenter/JM, OT	1.00	EA	4.00	4.00	\$ 143.52	\$ 574.08			
17	Laborer/JM, OT	1.00	EA	8.00	8.00	\$ 96.80	\$ 774.40			
18					52.00					
19										
20	EQUIPMENT									
21	Not Used	0.00	EA	0.00	0.00				\$ -	\$ -
22										
23										
24										
25	SHEET TOTALS						\$5,686.48	\$ 698.85		\$ -

OAKLAND UNIFIED SCHOOL DISTRICT

Division of Facilities Planning and Management • 955 High Street Oakland, California 94601 • Phone 510/535-2728 • Fax 510/535-7040

(Proposed Change Order) No. 5

PROJECT: Claremont Middle School MPR & Kitchen Project

DATE: OCTOBER 30, 2024

OWNER: OAKLAND UNIFIED SCHOOL DISTRICT

DSA FILE NO.: 01-119337

CONTRACTOR: ARNTZ BUILDERS INC.

DSA APP NO.: 01-119337

431 Payran

OUSD PROJECT #: 15127

Petaluma, CA 94952

PROJECT MANAGER: JaQuan Cornish

Contractor hereby submits this Change Order Request ("COR") pursuant to the contract documents, including but not limited to General Conditions sections 4.5.1, 4.5.2, 7.6, 7.7, 8.4.1, and 8.4.2.

DESCRIPTION OF PROPOSED CHANGES IN WORK (specifically refer to attached pages or incorporated documents): **PCO 120 – Barrier Fencing Near Building B. (Site Request):** Due to safety concerns, Claremont Staff requested added fencing barrier adjacent to Building B. between canopy columns C-A & C-B per sketches included in ASI 20.

OTHER PROPOSED CHANGES TO THE CONTRACT:

PCOs: #27, #58, #75, #97, #128, #139, #143, #144 & #146

PROPOSED ADJUSTMENT TO CONTRACT PRICE: **\$16,788.44**

PROPOSED ADJUSTMENT TO CONTRACT TIME: 0 calendar days

REASON FOR REQUEST (check one or more):

- Unforeseen Conditions
- Direction by Government Agency
- Owner Requested
- Design Omission
- Design Error
- Other: _____

OAKLAND UNIFIED SCHOOL DISTRICT

Division of Facilities Planning and Management • 955 High Street Oakland, California 94601 • Phone 510/535-2728 • Fax 510/535-7040

CERTIFICATION

I, Robert Arntz [name of declarant], declare the following:

Arntz Builders Inc. [Contractor company name] has contracted with Oakland Unified School District [public entity name] for the Claremont Middle School MPR & Kitchen Contract ("Contract"). Arntz Builders Inc. [Contractor company name] authorized me to prepare the attached Change Order Request ("COR") for money and/or time extension for Oakland Unified School District [public entity name] regarding this Contract (such COR being dated October 30, 2024, and entitled Change Order 1 and requesting \$2,153.35 and/or 0 additional days), and I prepared the attached COR. I am the most knowledgeable person at Arntz Builders Inc. [Contractor company name] regarding this COR.

The attached COR complies with all laws applicable to submission of a COR, including but not limited to California Penal Code section 72, Government Code sections 12650 et seq. (False Claims Act), and Business and Professions Code sections 17200 et seq. (Unfair Business Practices Act). I am aware that submission or certification of false claims, or other claims that violate law or the Contract, may lead to fines, imprisonment, and/or other serious legal consequences for myself or Arntz Builders [Contractor company name].

The attached COR does not breach the Contract, is not a false claim, does not violate any applicable law, satisfies all provisions of the Contract applicable to submission of the COR, only contains truthful and accurate supporting data, and only requests money and/or time extensions that accurately reflect the adjustments to money and time for which I believe that Oakland Unified School District [public entity name] is responsible under its Contract with Arntz Builders Inc. [Contractor company name].

While preparing this declaration and COR I consulted with others (including attorneys, consultants, or others who work for Arntz Builders Inc. [Contractor company name]) when necessary to ensure that the statements were true and correct.

Contractor understands and agrees that any COR submitted without this certification does not meet the terms of the Contract Documents; that Owner, or Owner's representatives, may reject the COR on that basis; and that unless Contractor properly and timely files the COR with the certification, Contractor cannot further pursue the COR in any forum and all rights to additional money or time for the issues covered by the COR are waived due to a condition precedent not having been satisfied.

I declare under the penalty of perjury under the laws of the State of California that the foregoing is true and correct. Executed October 30, 2024, at Oakland, California.

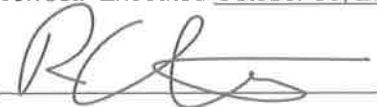
 [signature]

Robert Arntz [name of declarant]



Arntz Builders, Inc.

431 Payran St, Petaluma CA 94952 License No. 856393 T (707) 835-2900 F (707) 835-2993 www.arntzbuilders.com

Date: 11/2/23

Project Name: 2205 Claremont MS MPR & Kitchen

Generating Document: ASI 20

Arntz File #: 120

Arntz File Title: Barrier Fencing Near Bldg B

NOTIFICATION OF EXTRA:

The above referenced issue constitutes a changed condition resulting in extra work and extra costs. This condition will impact the project schedule.

Scope Change: Added fencing adjacent to Bldg B and between canopy columns C-A & C-B per attached sketches in ASI 20.

Location: Bldg B



Arntz Builders, Inc.

431 Payran St, Petaluma CA 94952 License No. 856393 T (707) 835-2900 F (707) 835-2993 www.amtzbuilders.com

July 9, 2024

Oakland Unified School District
1000 Broadway, Ste 300
Oakland, CA 94607

Subject: Claremont MS New Multi-Purpose and Kitchen
File No. . . . 120.1 Additional Site Fencing

Good Afternoon,

Additional site fencing and hand rails added per AS1 20R1

Prime Work:

Labor		\$3,971.00
Material		\$120.00
Equipment/Other		\$10,660.00
Prime Subtotal		\$14,751.00
Mark-Up	15.0%	\$2,212.65

TOTAL QUOTE \$16,788.44 ~~\$16,963.65~~

We reserve the right to submit a claim for an extension of time and for all related delay and inefficiency costs that may result due to the changed condition. The extent and amount will be determined at a later date when the full impact of changed condition can be evaluated and determined. All rights and remedies are reserved.

Sincerely,

ARNTZ BUILDERS

Robert Arntz
Project Manager

cc:
ST
enc

WELLANDER

STEEL BUILT

PROPOSAL 458

Arntz Builders, Inc.
431 Payran Street
Petaluma, CA 94952

DATE: 7/5/2024

PROJECT: Claremont Middle School - ASI 20R1

No.	DESCRIPTION	QTY	UNIT	\$/UNIT	TOTAL
1	Handrail	1	LS	10,395.36	10,395
	APPLICABLE TAX INCLUDED (Oakland, 10.250%)				
TOTAL					\$10,395

DESCRIPTION

Proposal in accordance with S Meek Architectures plans for "OUSD Claremont MS Multi-purpose Bldg & Kitchen" ASI 20R1 dated June 17, 2024, DSA Application No 01-119337

JOB CLARIFICATIONS

Price includes materials and labor for fabrication
Material prices contained in this quote are subject to escalation
Materials are subject to availability
Cold Galvanize compound will be used for touch up

Handrails - ASI 20R1

Qty: 41 LF +/-

Location A:

- (1) 1'-10" with intermediate rail
- (1) 8'-0" with (1) center post and intermediate rail
- (1) 12'-0" with (2) center posts and intermediate rail

Location B:

- (1) 8'-0" with (1) center post and intermediate rail

Location C:

- (1) 1'-8" without intermediate rail

Location D:

- (1) 6'-0" without intermediate rail and (1) center post
- (1) 3'-0" without intermediate rail

Finished Rail Height: 32"

Anticipate having the posts 6" longer for setting in core holes

FOB Jobsite (Delivered to jobsite for others to place)

1-1/4 Std Pipe (1.66" O.D.) - ASTM A53

Hot Dip Galvanize after fabrication

Site measurements Included

Submittal and shop drawings included for approval

Item Specific Exclusions:

Pipe Sleeves

Base Plates

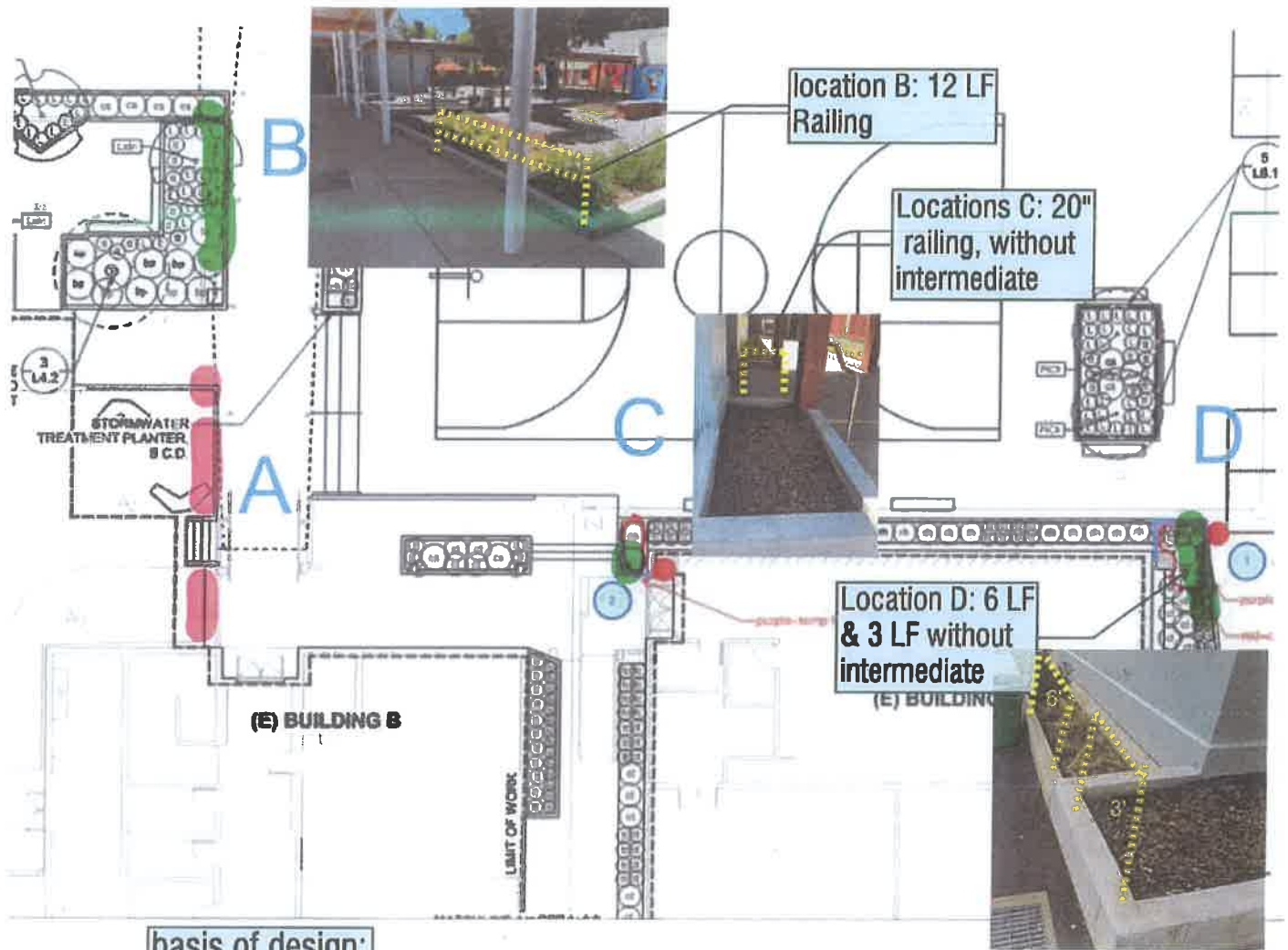

basis of design:
installed railings

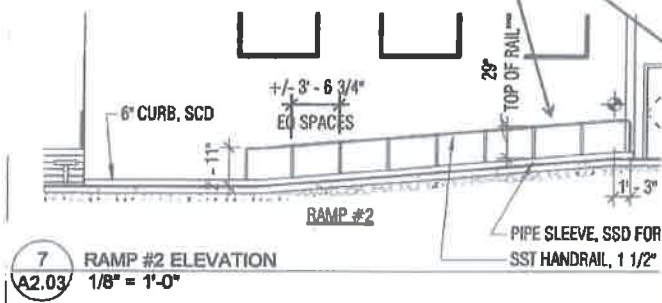

Claremont Middle School
MULTIPURPOSE BLDG & KITCHEN
 5750 College Ave
 Oakland CA 94618
 OUSD# 15127

SHEET TITLE:
 BLDG B FENCING

DSA # 01 - 117567	
SCALE:	1/4" = 1'-0"
DATE	5/17/2024
ASK-73	

BBM 3802/Claremont MP Bldg/CLSite_arch.rvt

4

Claremont Middle School
MULTIPURPOSE BLDG & KITCHEN
5750 College Ave
Oakland CA 94618
OUSD# 15127

DATE TITLE
BLDG B FENCING

195711 - 10 # VSD
SCALE: 1/4" = 1'-0"
DATE
8/17/2024

ASK-67

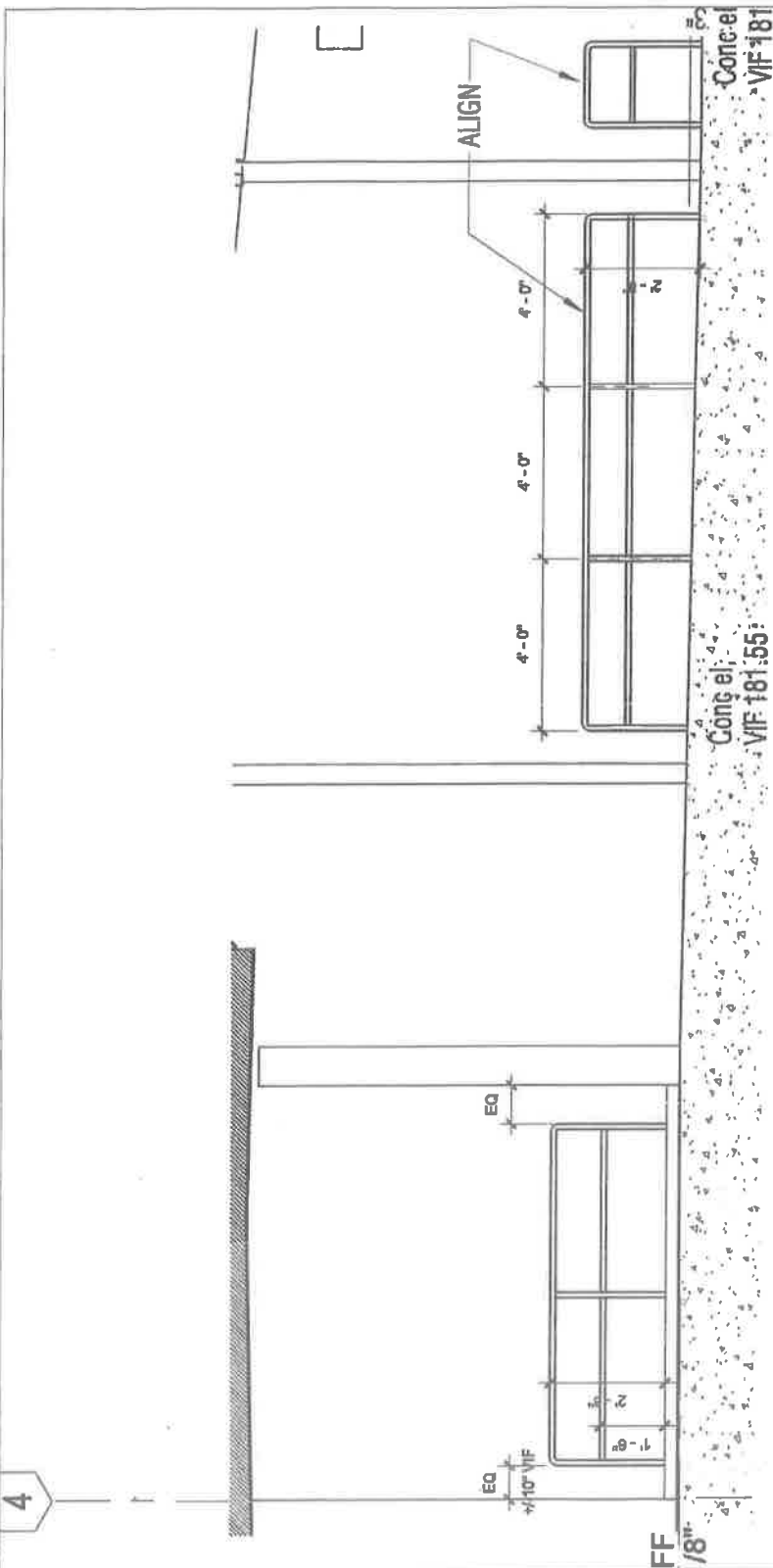

1 BLDG B FENCING
ASK-67 1/4" = 1'-0"

OAKLAND UNIFIED SCHOOL DISTRICT
CLAREMONT MS MULTI-PUROSE & KITCHEN BUILDING
PROJ # 15127
CCR#120.1 ABI FILE 120.1 - ADDITIONAL SITE FENCING

To: C. HENDERSON/PROJ. ENGR
From: Emil Vinuya, PE/Chief Cost Estimator
Date: 6-Aug-24

General Comments:

1 GENERAL CONTRACTOR: ARNTZ BUILDERS, INC.

Cost proposal appears reasonable.

2 GENERAL CONTRACTOR's COST PROPOSALS \$ 16,788.44

ESTIMATED CONSTRUCTION COST FOR CCR#120.1 \$ 16,788.44

Detailed Estimate

PROJECT 120 - BARRIER FENCING

CLAREMONT MS MULTI-PURPOSE & KITCHEN BUILDING											
										Date: _____	#REF)
M. TORRES/CM & C. HEMDERSON/PROJ. ENGR				LABOR COST				MATERIAL COST		EQUIPT. COST	
No.	CCR#120.1	No. of Units	Per	M.H. Per Unit	M. H. Total	Cost Per M. H.	Total Cost	Unit Cost	Total Cost	Unit Cost	Total Cost
GEN CONTRACTOR		ARNTZ BUILDERS INC.									
Project Description:		Additional Site fencing									
1	SCOPE OF WORK:										
2	Additional intermediate rail, 32"h including grouting	41	LF	0.83	34.00						
3											
4											
5											
6											
7											
8											
9											
10	MATERIALS										
11	Wellander Steel Built Proposal #48 - Handrails ASI20R1	41.00	LS	0.780	32.00			\$ 253.54	\$ 10,395.00		
12	Grout	2.00	EA	0.000	0.00			\$ 20.00	\$ 40.00		
13	Misc. Materials	1.00	LS	0.000	0.00			\$ 76.00	\$ 76.00		
14	Sales tax	10.25%	EA	0.000	0.00			\$ 40.00	\$ 4.10		
15											
16											
17	LABOR:										
18	Carpenter/JM	2.00	EA	16.00	32.00	\$ 112.31	\$ 3,593.92				
19	Carpenter/JM -Clean Out	1.00	EA	2.00	2.00	\$ 112.31	\$ 224.62				
20	Safety	0.00	LS	0.000	0.00	\$153.000	\$	OH			
20					34.00						
21											
22											
23	EQUIPMENT										
24	Core Machine Rental	1.00	EA	16.00	16.00					\$ 12.50	\$ 200.00
25	Core Bit Rental	1.00	EA	16.00	16.00					\$ 4.06	\$ 65.00
26											
27											
28	SHEET TOTALS						\$3,818.54		\$ 10,515.10		\$ 265.00

OAKLAND UNIFIED SCHOOL DISTRICT

Division of Facilities Planning and Management • 955 High Street Oakland, California 94601 • Phone 510/535-2728 • Fax 510/535-7040

(Proposed Change Order) No. 6

PROJECT: Claremont Middle School MPR & Kitchen Project

DATE: OCTOBER 30, 2024

DSA FILE NO.: 01-119337

OWNER: OAKLAND UNIFIED SCHOOL DISTRICT

DSA APP NO.: 01-119337

CONTRACTOR: ARNTZ BUILDERS INC.

OUSD PROJECT #: 15127

431 Payran

PROJECT MANAGER: JaQuan Cornish

Petaluma, CA 94952

Contractor hereby submits this Change Order Request ("COR") pursuant to the contract documents, including but not limited to General Conditions sections 4.5.1, 4.5.2, 7.6, 7.7, 8.4.1, and 8.4.2.

DESCRIPTION OF PROPOSED CHANGES IN WORK (specifically refer to attached pages or incorporated documents): **PCO 128 – Cat 6A Cables for Window Actuators (Error):** Per RFI 337 response, the contractor was directed to provide (2) Cat. 6A cables to window actuator controller; one for each controller. Run cables in the same conduit serving the telephone wall outlet in Storage Room 4. Provide additional conduit and j-boxes as needed to extend conduit down the north wall. Coordinate termination in the window actuator controllers with Controls Contractor. Detail was not reflected in the electrical drawings.

OTHER PROPOSED CHANGES TO THE CONTRACT:

PCOs: #27, #58, #75, #97, #120, #139, #143, #144 & #146

PROPOSED ADJUSTMENT TO CONTRACT PRICE: \$2,999.48

PROPOSED ADJUSTMENT TO CONTRACT TIME: 0 calendar days

REASON FOR REQUEST (check one or more):

- Unforeseen Conditions
- Direction by Government Agency
- Owner Requested
- Design Omission
- Design Error
- Other: _____

OAKLAND UNIFIED SCHOOL DISTRICT

Division of Facilities Planning and Management • 955 High Street Oakland, California 94601 • Phone 510/535-2728 • Fax 510/535-7040

CERTIFICATION

I, Robert Arntz [name of declarant], declare the following:

Arntz Builders Inc. [Contractor company name] has contracted with Oakland Unified School District [public entity name] for the Claremont Middle School MPR & Kitchen Contract ("Contract"). Arntz Builders Inc. [Contractor company name] authorized me to prepare the attached Change Order Request ("COR") for money and/or time extension for Oakland Unified School District [public entity name] regarding this Contract (such COR being dated October 30, 2024, and entitled Change Order 1 and requesting \$2,153.35 and/or 0 additional days), and I prepared the attached COR. I am the most knowledgeable person at Arntz Builders Inc. [Contractor company name] regarding this COR.

The attached COR complies with all laws applicable to submission of a COR, including but not limited to California Penal Code section 72, Government Code sections 12650 et seq. (False Claims Act), and Business and Professions Code sections 17200 et seq. (Unfair Business Practices Act). I am aware that submission or certification of false claims, or other claims that violate law or the Contract, may lead to fines, imprisonment, and/or other serious legal consequences for myself or Arntz Builders [Contractor company name].

The attached COR does not breach the Contract, is not a false claim, does not violate any applicable law, satisfies all provisions of the Contract applicable to submission of the COR, only contains truthful and accurate supporting data, and only requests money and/or time extensions that accurately reflect the adjustments to money and time for which I believe that Oakland Unified School District [public entity name] is responsible under its Contract with Arntz Builders Inc. [Contractor company name].

While preparing this declaration and COR I consulted with others (including attorneys, consultants, or others who work for Arntz Builders Inc. [Contractor company name]) when necessary to ensure that the statements were true and correct.

Contractor understands and agrees that any COR submitted without this certification does not meet the terms of the Contract Documents; that Owner, or Owner's representatives, may reject the COR on that basis; and that unless Contractor properly and timely files the COR with the certification, Contractor cannot further pursue the COR in any forum and all rights to additional money or time for the issues covered by the COR are waived due to a condition precedent not having been satisfied.

I declare under the penalty of perjury under the laws of the State of California that the foregoing is true and correct. Executed October 30, 2024, at Oakland, California.

 [signature]

Robert Arntz [name of declarant]



Arntz Builders, Inc.

431 Payran St, Petaluma CA 94952 License No. 856393 T (707) 835-2900 F (707) 835-2993 www.arntzbuilders.com

Date: 11/13/23

Project Name: 2205 Claremont MS MPR & Kitchen

Generating Document: RFI 337

Arntz File #: 128

Arntz File Title: Cat 6A Cables for Window Actuators

NOTIFICATION OF EXTRA:

The above referenced issue constitutes a changed condition resulting in extra work and extra costs. This condition will impact the project schedule.

Scope Change: Per RFI 337 response: "Provide (2) Cat. 6A cables to window actuators controller, one for each controller. Homerun cables in the same conduit serving the telephone wall outlet in Storage Room 4. Provide additional conduit and j-boxes as needed to extend conduit down the north wall. Coordinate termination in the window actuator controllers with Controls Contractor.", which was not shown on the electrical drawings.

Location: Storage Room 4



Arntz Builders, Inc.
 431 Payran Street
 Petaluma, California 94952
 P: +17078352900

**Project: 2205 Claremont Middle School Multi-Purpose Building
 & Kitchen**
 5750 College Ave
 Oakland , California 94618

RFI #337: Window Control Interface

Status	Open		
To	Jake Hankins (Arntz Builders, Inc.)	From	Jake Hankins (Arntz Builders, Inc.) 431 Payran Street Petaluma, California 94952
Date Initiated	Jun 22, 2023	Due Date	Jun 29, 2023
Location		Project Stage	Course of Construction
Cost Impact	No	Schedule Impact	No
Spec Section		Cost Code	
Drawing Number	M1.1	Reference	
Linked Drawings	M1.1		
Received From	Tristan Flores (Broadway Mechanical)		
Copies To	David Arntz (Arntz Builders, Inc.), Robert Arntz (Arntz Builders, Inc.), Cole Azamar (Arntz Builders, Inc.), Jake Hankins (Arntz Builders, Inc.), Nick Ivashkevich (Arntz Builders, Inc.)		

Activity

Question

Question from Jake Hankins Arntz Builders, Inc. on Thursday, Jun 22, 2023 at 06:16 AM PDT

This RFI is to confirm the approved and accepted means and methods to communicate with the window actuator controllers. Multiple meetings, emails and conversations regarding the window controller interface capabilities were coordinated. It has been confirmed that the window actuator control submittals provided communication through BACnet/IP. Syserco confirms that the BMS system can communicate over BACnet/IP. This will require a network drop (installed by others) and IP address to the window controllers. It has also been confirmed by the window vendor that the open and close status and command is capable through the BACnet/IP communication. The need for separate window sensors and the requirement for Panel 6 was by default changed. This form of communication for ventilation control was explained, accepted and approved on the engineered control drawing submittals.

Attachments

M1.1_FLOOR PLAN - MECHANICAL OVERALL Rev.0 (2).pdf, RFI 11 - Window interface protocol.pdf

Syserco is indicating that they do not need a panel, due to the IP communication. Provide credit for Panel 6 to be eliminated and provide proposed revisions to sheet /M7.0. This response does not add costs.

responses from Syserco/Arntz to the 6/27/23 question posted on Colbi docs:

- 1) It is confirmed with Syserco that there are no other anticipated network drops. All other HVAC devices communicate over an MS/TP network. No devices in submittal 23 09 00-3.0 indicate communication over an IP network.
- 2) The design calls for existing BMS connection back to Bldg A (conduit provided in base scope). It is confirmed with Syserco that this is via IP.

Network connection for the window actuators will be able to communicate with the new BMS panels and the existing BMS system.

Response by FWA:

Provide (2) Cat. 6A cables to window actuator controller, one for each controller. Homerun cables in the same conduit serving the telephone wall outlet in Storage Room 4. Provide additional conduit and j-boxes as needed to extend conduit down the north wall. Coordinate termination in the window actuator controllers with Controls Contractor.



S MEEK
ARCHITECTURE
3000 24th Street
San Francisco, CA 94110
415-543-6995

Alter
Engineering & Architecture
1624 Franklin St., Suite 1000
Oakland, CA 94612



**CLAREMONT
MIDDLE
SCHOOL**
5750 College Ave
Oakland, CA 94618

**Multi-Purpose
Building &
Kitchen**

Oakland
Unified
School
District

Issue Set / Revisions	Date
1. Schematic Design	7/17/20
2. Design Development	9/23/20
3. 50% Construction Doc	11/17/20
4. 75% Construction Doc	1/3/22
5. DSA Submission	2/4/21
6. DSA Resubmission	11/15/21

**FLOOR PLAN -
MECHANICAL
OVERALL
M1.1**

11/15/21 Issue Date
15/27 OUSD Job No.

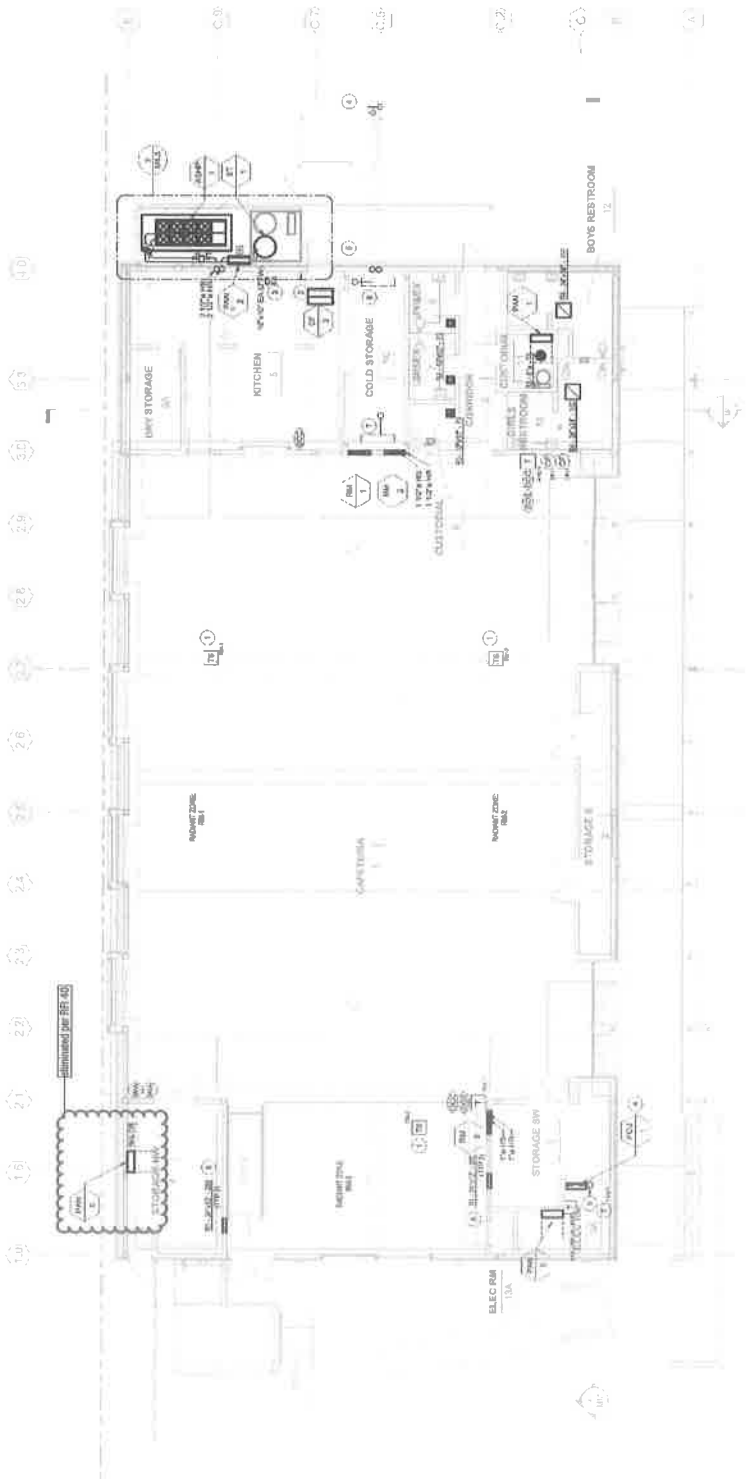

MECHANICAL FIRST FLOOR - OVERALL
1/4" = 1'-0"

GENERAL NOTES

- A. MEASURE PROJECT IN PLACE, PLUMB, SLOPE TO PROJECT DETAILS
- B. VERIFY ALL MECHANICAL EQUIPMENT IS LISTED ON THE MECHANICAL SCHEDULES
- C. MANUFACTURER SPECIFIC DETAILS AND SIZES FOR ADDITIONAL EQUIPMENT
- D. VERIFY ALL MECHANICAL EQUIPMENT IS LISTED ON THE MECHANICAL SCHEDULES
- E. VERIFY ALL MECHANICAL EQUIPMENT IS LISTED ON THE MECHANICAL SCHEDULES
- F. VERIFY ALL MECHANICAL EQUIPMENT IS LISTED ON THE MECHANICAL SCHEDULES
- G. VERIFY ALL MECHANICAL EQUIPMENT IS LISTED ON THE MECHANICAL SCHEDULES
- H. VERIFY ALL MECHANICAL EQUIPMENT IS LISTED ON THE MECHANICAL SCHEDULES
- I. VERIFY ALL MECHANICAL EQUIPMENT IS LISTED ON THE MECHANICAL SCHEDULES
- J. VERIFY ALL MECHANICAL EQUIPMENT IS LISTED ON THE MECHANICAL SCHEDULES

SHEET NOTES

1. SHAD TRAVELER USE AS SHOWN
2. SHAD TRAVELER USE AS SHOWN
3. SHAD TRAVELER USE AS SHOWN
4. SHAD TRAVELER USE AS SHOWN
5. SHAD TRAVELER USE AS SHOWN
6. SHAD TRAVELER USE AS SHOWN
7. SHAD TRAVELER USE AS SHOWN
8. SHAD TRAVELER USE AS SHOWN
9. SHAD TRAVELER USE AS SHOWN
10. SHAD TRAVELER USE AS SHOWN



TULUM SYSTEMS

WORK ORDER/CHANGE ORDER FORM

CUSTOMER INFORMATION	SITE INFORMATION
Company: Arntz Builders	Company: Arntz Builders
Address: 431 Payran Street	Address: 5750 College Avenue
City, State, Zip: Petaluma, CA 94952	City, State, Zip: Berkeley, CA
Phone: (707) 835-2900	Phone: 707-790-3002 707-796-3008
Fax	Fax
Contact Name: Robert Arntz	Contact Name: Jake Hankins Cole Azamar

CUSTOMER REQUEST:
Add conduit and Cat 6A cable from IDF to shade controllers.

Reference document: RFI 337/File #128

WORK PERFORMED/SCHEDULED:
Conduit back to IDF.

WORK TO CONTINUE

MATERIAL USED:	PERSONNEL USED:
300' - CAT 6A cable	Personnel Classification: JW
300' - pull string	# of Personnel: 2
150' - 3/4" Conduit	
Supports	
Connectors, coupling, T	

TIME IN: 7:00 AM TIME OUT: 3:30 PM
 HOURS WORKED PER PERSONNEL: 8 HOURS
 HOURS BILLED: 16 HOURS

START DATE: 11/9/23
 COMPLETION DATE: 11/9/23

MINIMUM CHARGES: SERVICE CALLS: 2 hours (Plus any additional time required to complete work)
 INVESTIGATION CALLS: 4 hours
 CHANGE ORDERS: 2 hours (Plus any meeting site walk, investigation required)

x Rafael Zamora

TULUM TECH/ELECTRICIAN/PROGRAMMER

x Verified T & Money - Spot 1/2 (for)
 IOR/AOR/OWNER SIGNATURE

11 / 9 / 23

DATE

11 / 13 / 23
 DATE

x _____
 CUSTOMER SIGNATURE

_____/_____/_____
 DATE

*** INVOICE TO BE MAILED UPON COMPLETION OF WORK ***



Arntz Builders, Inc.

431 Payran St, Petaluma CA 94952 License No. 856393 T (707) 835-2900 F (707) 835-2993 www.arntzbuilders.com

December 11, 2023

Oakland Unified School District
1000 Broadway, Ste 300
Oakland, CA 94607

Subject Claremont MS New Multi-Purpose and Kitchen
File No. 128 Cat 6A Cables for Window Actuators

Good Afternoon,

Per RFI 337 response: "Provide (2) Cat. 6A cables to window actuators controller, one for each controller. Homerun cables in the same conduit serving the telephone wall outlet in Storage Room 4. Provide additional conduit and j-boxes as needed to extend conduit down the north wall. Coordinate termination in the window actuator controllers with Controls Contractor.", which was not shown on the electrical drawings.

Subcontractor Work:

Tulum Systems		<u>\$3,332.84</u>
Subcontractor Subtotal		<u>\$3,332.84</u>
Mark-Up	5.0%	<u>\$166.64</u>

TOTAL QUOTE **\$3,499.48**

We reserve the right to submit a claim for an extension of time and for all related delay and inefficiency costs that may result due to the changed condition. The extent and amount will be determined at a later date when the full impact of changed condition can be evaluated and determined. All rights and remedies are reserved.

Sincerely,

ARNTZ BUILDERS

Robert Arntz
Project Manager

cc:
ST
enc

INTELLIBID COST BREAKDOWN

SHEET S2 OF S3

CONTRACTOR: TULUM SYSTEMS
PROJECT NAME: Claremont MPR & Kitchen
PROJECT NUMBER:
CHANGE ORDER NUMBER: TULUM-Claremont MPR-025 **DATE:** 11/13/2023
CHANGE ORDER DESCRIPTION: Amtz RFI 337 - Add CAT6A drops for window shade controllers

LABOR					
NAME	HOURS	RATE	TOTAL		
DIRECT COSTS	Electrical - Journeyman	16.0	\$ 136.69	\$	2,187.04
TOTAL LABOR COSTS (Transfers to Line 1 of Sheet S1)				\$	2,187.04
TOTAL BURDEN LABOR COSTS (Transfers to Line 4 of Sheet S1)				\$	-

MATERIALS				
DESCRIPTION	QUANTITY	RATE	COST	
MATERIAL - REXEL	1	476.30	\$	476.30
MATERIAL COSTS (Without Sales Tax)			\$	476.30
FREIGHT, SHIPPING, HANDLING			\$	-
SUBTOTAL MATERIAL COSTS (Without Sales Tax) - Line 5 of Sheet 1			\$	476.30
SALES TAX ON MATERIAL AT 10.75% - Line 6 of Sheet 1			\$	51.20
TOTAL MATERIAL COSTS			\$	527.50

EQUIPMENT				
SIZE AND TYPE	I.D. #	HOURS	RATE	TOTAL
Scissor Lift, 30 ft	DAY	1	\$ 286.00	\$ 286.00
Sub total			\$	286.00
Tax			\$	29.32
TOTAL EQUIPMENT RENTAL COSTS (Transfers to Line 7 of Sheet S1)			\$	315.32



← Cart

Cart #: 578967

Order Summary

Items:	6
Subtotal:	\$476.30

Final price, taxes, and other fees calculated on the checkout page

MULTIPLE
EMT Conduit, 3/4", Steel, 10'
 Item #: 49014 Cat #: 075 UPC: 091111020025

Qty:	\$153.35
150	\$1.02 FT

Oakland #2831



22.320 in stock
 1,826,569 Company wide

— 150 +

APPLETON
EMT Compression Connector, 3/4" Diameter, Steel/Zinc
 Item #: 22514 Cat #: 7075S UPC:

Qty:	\$5.18
6	\$0.86 EA

Oakland #2831



0 in stock
 54.751 Company wide

— 15 +

PANDUIT

Copper Cable, Cat 6A, Vari-MaTriX, 4-Pair, 23 AWG, White

Item #: 1274405 Cat #: PUP6AV04WH-G UPC: 613056368156

Qty: **\$261.43**
300 \$0.87 EA

Oakland #2831

⋮

0 in stock

0 Company wide

① Call for availability

— 300 +



215 Fourier Ave.
Fremont, CA 94539
Phone: 510 498-1171
Fax: 510 498-1160

Contractors License # 483939
www.syserco.com

Branch Office: Petaluma, CA

Request for Information

To:	Francis Silagon	Phone:	415-543-5505
Company:	Broadway Mechanical	Fax:	
Project:	Oakland USD Claremont Middle School	RFI Date:	06.20.2023
Syserco Job #:	1118CO22KT	Syserco RFI #:	11
Requested By:	Tristan Flores	Dwg / Spec Ref:	M1.1
Subject:	Window Control Interface		

Response / Confirmation needed by: Within 1 Days

- UNABLE TO PROCEED – We are unable to proceed with this work until a written response is received.
 COST IMPACT – This RFI represents additional work beyond the current scope of our contract.
- Information not shown on Contract documents Interpretation of Contract documents required
 Conflict in Specifications or Drawings Coordination Issue
 Other: **Communication**
-

Questions / Clarifications:

This RFI is to confirm the approved and accepted means and methods to communicate with the window actuator controllers. Multiple meetings, emails and conversations regarding the window controller interface capabilities were coordinated. It has been confirmed that the window actuator control submittals provided communication through BACnet/IP. Syserco confirms that the BMS system can communicate over BACnet/IP. This will require a network drop (installed by others) and IP address to the window controllers. It has also been confirmed by the window vendor that the open and close status and command is capable through the BACnet/IP communication. The need for separate window sensors and the requirement for Panel 6 was by default changed. This form of communication for ventilation control was explained, accepted and approved on the engineered control drawing submittals.

OAKLAND UNIFIED SCHOOL DISTRICT
CLAREMONT MS MULTI-PURPOSE & KITCHEN BUILDING
PROJ # 15127

CCR#128 ABI FILE 128 - CAT 6A CABLES FOR WINDOW ACTUATORS (T&M)

To: M. TORRES/CM; CHENDERSON
From: Emil Vinuya, PE/Chief Cost Estimator
Date: 10-Jul-24

General Comments:

1 GENERAL CONTRACTOR: ARNTZ BUILDERS, INC.

Credit has been accepted for the Panel 6 (\$500)

2 SUBCONTRACTOR: TULUM

Manhours based on IOR-Signed T&M tags.

Materials prices provided by Sub appears reasonable based on quotes from local supplier - Rexel.

3 GENERAL CONTRACTOR's COST PROPOSALS \$ 2,999.48

ESTIMATED CONSTRUCTION COST FOR CCR#128 R \$ 2,999.48

COST ESTIMATE SUMMARY

Project Name:	OAKLAND UNIFIED SCHOOL DISTRICT	Project Number:	15127
CCR#124	CLAREMONT MS MULTI-PURPOSE & KITCHEN BUILDING	Date:	10-Jul-24
	Oakland, CA		

Decription : CCR#128
ABI FILE 128 - CAT 6A CABLES FOR WINDOW ACTUATORS (T&M)

Reference Drawing: Cost Proposal dated 12/11/2023
SUBCONTRACTOR: TULUM

	Total Labor	B) Total Material Costs	C) Total Rental Equipment Cost	TOTAL
1	SHEET 1 of 2			
2	SHEET 2 of 2			
3	\$ 2,187.04	\$ 476.30	\$ 286.00	\$ 2,949.34
4				
5				
6				
7	\$ 2,187.04	+ \$ 476.30	+ \$ 286.00	= \$ 2,949.34
8				
9	Expenses:			
10	Material Sales Tax.....		10.25% of Total Material:	\$ 51.20
11	Rental Sales Tax.....		10.25% of Total Rental:	\$ 29.32
12				
13			Subtotal - Line 7 thru 12:	\$ 3,029.85
14				
15	General Contractor OH, B&IP, &P:		10.00% * Total Cost	\$ 302.99
19			*(Overhead, Bond & Insurance Premiums & Profit)	
20				
21			Subtotal - Line 13 thru 19:	\$ 3,332.84
22				
23			Sub-Subcontractor's Cost - None	\$ -
24				
25			SUBTOTAL	\$ -
26	General Contractor OH&P on Sub Cost:		5.00% *	\$ -
27				
28			TOTAL PROBABLE CONSTRUCTION COST - TULUM	\$ 3,332.84

OAKLAND UNIFIED SCHOOL DISTRICT

Division of Facilities Planning and Management • 955 High Street Oakland, California 94601 • Phone 510/535-2728 • Fax 510/535-7040

(Proposed Change Order) No. 7

PROJECT: Claremont Middle School MPR & Kitchen Project

DATE: OCTOBER 30, 2024

DSA FILE NO.: 01-119337

OWNER: OAKLAND UNIFIED SCHOOL DISTRICT

DSA APP NO.: 01-119337

CONTRACTOR: ARNTZ BUILDERS INC.

OUSD PROJECT #: 15127

431 Payran

PROJECT MANAGER: JaQuan Cornish

Petaluma, CA 94952

Contractor hereby submits this Change Order Request ("COR") pursuant to the contract documents, including but not limited to General Conditions sections 4.5.1, 4.5.2, 7.6, 7.7, 8.4.1, and 8.4.2.

DESCRIPTION OF PROPOSED CHANGES IN WORK (specifically refer to attached pages or incorporated documents): **PCO 139 – Set Up Transformers for Vertical Lift Doors (Omission):** The contract electrical requirements are not sufficient for the vertical lift doors. Per RFI 444R1 response, the contractor was directed to provide a total of (3) buck-boost transformers, wired as autotransformers to boost for source voltage of 208V to load voltage of 240V, single phase, to meet the vertical lift door's operating voltage requirement.

OTHER PROPOSED CHANGES TO THE CONTRACT:

PCOs: #27, #58, #75, #97, #120, #128, #143, #144 & #146

PROPOSED ADJUSTMENT TO CONTRACT PRICE: **\$7,733.11**

PROPOSED ADJUSTMENT TO CONTRACT TIME: 0 calendar days

REASON FOR REQUEST (check one or more):

- Unforeseen Conditions
- Direction by Government Agency
- Owner Requested
- Design Omission
- Design Error
- Other: _____

OAKLAND UNIFIED SCHOOL DISTRICT

Division of Facilities Planning and Management • 955 High Street Oakland, California 94601 • Phone 510/535-2728 • Fax 510/535-7040

CERTIFICATION

I, Robert Arntz [name of declarant], declare the following:

Arntz Builders Inc. [Contractor company name] has contracted with Oakland Unified School District [public entity name] for the Claremont Middle School MPR & Kitchen Contract ("Contract"). Arntz Builders Inc. [Contractor company name] authorized me to prepare the attached Change Order Request ("COR") for money and/or time extension for Oakland Unified School District [public entity name] regarding this Contract (such COR being dated October 30, 2024, and entitled Change Order 1 and requesting \$2,153.35 and/or 0 additional days), and I prepared the attached COR. I am the most knowledgeable person at Arntz Builders Inc. [Contractor company name] regarding this COR.

The attached COR complies with all laws applicable to submission of a COR, including but not limited to California Penal Code section 72, Government Code sections 12650 et seq. (False Claims Act), and Business and Professions Code sections 17200 et seq. (Unfair Business Practices Act). I am aware that submission or certification of false claims, or other claims that violate law or the Contract, may lead to fines, imprisonment, and/or other serious legal consequences for myself or Arntz Builders [Contractor company name].

The attached COR does not breach the Contract, is not a false claim, does not violate any applicable law, satisfies all provisions of the Contract applicable to submission of the COR, only contains truthful and accurate supporting data, and only requests money and/or time extensions that accurately reflect the adjustments to money and time for which I believe that Oakland Unified School District [public entity name] is responsible under its Contract with Arntz Builders Inc. [Contractor company name].

While preparing this declaration and COR I consulted with others (including attorneys, consultants, or others who work for Arntz Builders Inc. [Contractor company name]) when necessary to ensure that the statements were true and correct.

Contractor understands and agrees that any COR submitted without this certification does not meet the terms of the Contract Documents; that Owner, or Owner's representatives, may reject the COR on that basis; and that unless Contractor properly and timely files the COR with the certification, Contractor cannot further pursue the COR in any forum and all rights to additional money or time for the issues covered by the COR are waived due to a condition precedent not having been satisfied.

I declare under the penalty of perjury under the laws of the State of California that the foregoing is true and correct. Executed October 30, 2024, at Oakland, California.

 [signature]

Robert Arntz [name of declarant]



Arntz Builders, Inc.

431 Payran St, Petaluma CA 94952 License No. 856393 T (707) 835-2900 F (707) 835-2993 www.arntzbuilders.com

Date: 2/21/24

Project Name: 2205 Claremont MS MPR & Kitchen

Generating Document: RFI 444R1

Arntz File #: 139

Arntz File Title: Set Up Transformers for VLD's

NOTIFICATION OF EXTRA:

The above referenced issue constitutes a changed condition resulting in extra work and extra costs. This condition will impact the project schedule.

Scope Change: The contract electrical requirements is not sufficient for the vertical lift doors. Per RFI 444R1 response, provide a total of (3) buck-boost transformers, wired as autotransformer to boost from source voltage of 208V to load voltage of 240V, single phase, to meet the vertical lift door's operating voltage requirement.

Location: VLD Locations



Arntz Builders, Inc.

431 Payran St, Petaluma CA 94952 License No. 856393 T (707) 835-2900 F (707) 835-2993 www.arntzbuilders.com

June 12, 2024

Oakland Unified School District
1000 Broadway, Ste 300
Oakland, CA 94607

Subject : Claremont MS New Multi-Purpose and Kitchen
File No. 139 Set Up Transformers for VLD's

Good Afternoon,

The contract electrical requirements is not sufficient for the vertical lift doors. Per RFI 444R1 response, provide a total of (3) buck-boost transformers, wired as autotransformer to boost from source voltage of 208V to load voltage of 240V, single phase, to meet the vertical lift door's operating voltage requirement.

Subcontractor Work:

Tulum Systems		<u>\$7,364.87</u>
Subcontractor Subtotal		<u>\$7,364.87</u>
Mark-Up	5.0%	<u>\$368.24</u>

TOTAL QUOTE **\$7,733.11**

We reserve the right to submit a claim for an extension of time and for all related delay and inefficiency costs that may result due to the changed condition. The extent and amount will be determined at a later date when the full impact of changed condition can be evaluated and determined. All rights and remedies are reserved.

Sincerely,

ARNTZ BUILDERS

Robert Arntz
Project Manager

cc:
ST
enc



REXEL 2831 SLE OAKLAND
 955 KENNEDY ST
 OAKLAND, CA 94606-5336
 Fax 510-352-9980



Quotation

QUOTE DATE	QUOTE NUMBER	PAGE NO.
02/13/2024	S138792851	1 of 1
CUST PO#	ACME TXR QTE	
JOB/REL#		

QUOTE TO:

TULUM INNOVATIVE ENGINEERING INC
 DBA TULUM SYSTEMS
 3101 HYDE ST
 OAKLAND, CA 94601-1920

SHIP TO:

TULUM INNOVATIVE ENGINEERING INC
 DBA TULUM SYSTEMS
 3101 HYDE ST
 OAKLAND, CA 94601-1920

CUSTOMER NUMBER	CUSTOMER PHONE#	ORDERED BY	OUTSIDE SALESPERSON	
847907	510-773-1833	Rafael Z.	Rachel Kunzer	
WRITER	WRITER PHONE#	WRITER EMAIL		
David Sauneuf	510 347 1118	David.Sauneuf@Rexelusa.com		
INSIDE SALESPERSON	SHIP VIA	TERMS	SHIP DATE	FREIGHT ALLOWED
David Sauneuf	PICK UP	PROX 45	03/01/2024	No
ORDER QTY	DESCRIPTION	UNIT PRICE	EXT PRICE	
3ea	ACM T181059 TFMR 1PH .75KVA 120X240-16/32 Our Pn: 74497 UPC: 04750308645 *** STOCK IN SANTA FE SPRINGS, CA *** FRT IS NOT ALLOWED ***	214.373/EA	643.12	

Prices are subject to change at any time prior to shipment unless agreed to otherwise in writing signed by an authorized Seller representative. Orders related to this quotation must be received, accepted and released by Seller within 48 hours of issuance of the quotation and are subject to availability. Many of Seller's manufacturing partners have advised that until further notice they reserve the right to amend the delivery date, price, scope and quantity of supply and/or other terms and conditions set out in their offer or quotation and Seller equally reserves the right to pass through any such changes from its manufacturing partners to the Buyer. Delivery dates are estimated only. Seller shall not be liable for failure to meet such dates resulting from product shortages or manufacturing delays. Be advised that Seller considers any changes imposed by its manufacturing partners and other vendors outside of Seller's reasonable control and therefore subject to Force Majeure provisions or similar common law doctrines such as "frustration" or "impossibility". Seller's Standard Terms and Conditions of Sale are incorporated by reference into this quotation. A copy of the most current version of Seller's Standard Terms and Conditions of Sale is available at [https://www.rexelusa.com/standard-terms-conditions](#). Full phone support at (866) 739-8572.

Subtotal	643.12
S&H Charges	0.00
Sales Tax	65.92
Total	709.04

— 12 +

APPLETON
EMT Conduit Strap, 1-Hole, 1", Steel

Item #: 20222 Cat #: 1903 UPC: 687855219032

Qty: **\$4.13**
10 \$0.41 EA

Oakland #2831

0 in stock
24,302 Company wide

— 10 +

APPLETON
EMT Compression Connector, 1" Diameter, Steel/Zinc

Item #: 22691 Cat #: 7100S UPC:

Qty: **\$19.69**
16 \$1.23 EA

Oakland #2831

0 in stock
10,456 Company wide

— 16 +

EATON B-LINE
Conduit Clamp, 1" Diameter, Pre-Assembled, Steel/Zinc

Item #: 271724 Cat #: B2003PAZN UPC: 781011608347

Qty: **\$15.11**
10 \$1.51 EA

Oakland #2831

212 in stock
9,848 Company wide

50 +

APPLETON

4" Square Box, Welded, Metallic, 2-1/8" Deep

Item #: 40603 Cat #: 4SD-Ek UPC: 687855771264

Qty: **\$8.85**
3 \$2.95 EA

Oakland #2831

0 in stock
37,647 Company wide

- 3 +

APPLETON

4" Square Cover, Flat, Blank

Item #: 22520 Cat #: 8465 UPC: 687855776450

Qty: **\$2.37**
3 \$0.79 EA

Oakland #2831

0 in stock
32,518 Company wide

- 3 +

Buck-Boost Transformers

Section 7 | Selection Charts



Single Phase Application

Line Voltage (Available)

Load Voltage (Output)

Boosting								Bucking					
95	100	105	208	215	215	220	225	135	240	240	245	250	255
120	114	119	240	244	230	235	240	119	208	225	230	234	239

Catalog Number			0.19	0.36	0.37	0.38	0.38	0.72	0.73	0.75	0.42	0.37	0.75	0.77	0.78	0.80
T181054	Load	kVA	0.19	0.36	0.37	0.38	0.38	0.72	0.73	0.75	0.42	0.37	0.75	0.77	0.78	0.80
		Amps	1.56	3.13	3.13	1.56	1.56	3.13	3.13	3.13	3.64	1.77	3.33	3.33	3.33	3.33
		Maximum Size of Fuse or Breaker	6	6	6	6	6	6	6	6	6	3	6	6	6	6
T181055	Load	kVA	0.38	0.71	0.74	0.75	0.76	1.44	1.47	1.50	0.84	0.74	1.50	1.53	1.56	1.59
		Amps	3.13	6.25	6.25	3.13	3.13	6.25	6.25	6.25	7.08	3.54	6.67	6.67	6.67	6.67
		Maximum Size of Fuse or Breaker	10	15	6	6	15	15	15	15	15	6	15	15	15	15
T181056	Load	kVA	0.58	1.07	1.12	1.13	1.14	2.16	2.20	2.25	1.26	1.11	2.25	2.30	2.34	2.39
		Amps	4.69	9.38	9.38	4.69	4.69	9.38	9.38	9.38	10.63	5.31	10.00	10.00	10.00	10.00
		Maximum Size of Fuse or Breaker	10	15	15	10	10	15	15	15	15	6	15	15	15	15
T181057	Load	kVA	0.94	1.78	1.86	1.88	1.91	3.59	3.67	3.75	2.11	1.84	3.75	3.83	3.90	3.98
		Amps	7.81	15.63	15.63	7.81	7.81	15.63	15.63	15.63	17.71	8.85	16.67	16.67	16.67	16.67
		Maximum Size of Fuse or Breaker	15	25	25	15	15	25	25	25	20	15	20	20	20	20
T181058	Load	kVA	1.88	3.56	3.72	3.75	3.81	7.19	7.34	7.50	4.21	3.68	7.50	7.67	7.80	7.97
		Amps	15.63	31.25	31.25	15.63	15.63	31.25	31.25	31.25	35.42	17.71	33.33	33.33	33.33	33.33
		Maximum Size of Fuse or Breaker	25	45	45	25	25	45	45	45	40	20	40	40	40	40
T181059	Load	kVA	2.81	5.34	5.58	5.63	5.72	10.78	11.02	11.25	6.32	5.53	11.25	11.50	11.70	11.95
		Amps	23.44	46.88	46.88	23.44	23.44	46.88	46.88	46.88	53.13	26.56	50.00	50.00	50.00	50.00
		Maximum Size of Fuse or Breaker	40	70	70	40	40	70	70	70	60	30	60	60	60	60
T113073	Load	kVA	3.75	7.13	7.44	7.50	7.63	14.38	14.89	15.00	8.43	7.37	15.00	15.33	15.80	15.93
		Amps	31.25	62.50	62.50	31.25	31.25	62.50	62.50	62.50	70.83	35.42	66.67	66.67	66.67	66.67
		Maximum Size of Fuse or Breaker	50	90	90	50	50	90	90	90	80	40	80	80	80	80
T113074	Load	kVA	5.63	10.89	11.16	11.25	11.44	21.66	22.03	22.50	12.64	11.05	22.50	23.00	23.40	23.90
		Amps	46.90	93.80	93.80	46.90	46.90	93.80	93.80	93.80	106.30	53.10	100.00	100.00	100.00	100.00
		Maximum Size of Fuse or Breaker	80	150	150	70	70	125	125	125	125	60	125	125	125	125
T113075	Load	kVA	7.50	14.25	14.88	15.00	15.25	28.75	29.38	30.00	16.86	14.73	30.00	30.67	31.20	31.87
		Amps	62.50	125.00	125.00	62.50	62.50	125.00	125.00	125.00	141.70	70.80	133.30	133.30	133.30	133.30
		Maximum Size of Fuse or Breaker	100	200	200	90	90	175	175	175	175	80	175	175	175	175
T113076	Load	kVA	11.25	21.36	22.31	22.50	22.88	43.13	44.06	45.00	25.29	22.10	45.00	46.00	46.80	47.80
		Amps	93.80	187.50	187.50	93.80	93.80	187.50	187.50	187.50	212.50	106.30	200.00	200.00	200.00	200.00
		Maximum Size of Fuse or Breaker	150	300	300	150	150	250	250	250	250	125	250	250	250	250
T113077	Load	kVA	18.75	35.63	37.19	37.50	38.13	71.66	73.44	75.00	42.15	36.83	75.00	76.67	78.00	79.67
		Amps	156.30	312.50	312.50	156.30	156.30	312.50	312.50	312.50	354.20	177.10	333.30	333.30	333.30	333.30
		Maximum Size of Fuse or Breaker	250	450	450	225	225	450	450	450	400	200	400	400	400	400
T213078 ⓪	Load	kVA	28.10	53.40	55.80	56.30	57.20	107.80	110.20	112.50	63.20	55.30	112.50	115.00	117.00	118.50
		Amps	234.40	468.80	468.80	234.40	234.40	468.80	468.80	468.80	531.30	265.60	500.00	500.00	500.00	500.00
		Maximum Size of Fuse or Breaker	400	700	700	350	350	700	700	700	600	300	600	600	600	600
T213079 ⓪	Load	kVA	37.50	71.30	74.40	75.00	76.30	143.80	146.90	150.00	84.30	73.70	150.00	153.30	156.00	159.30
		Amps	312.50	625.00	625.00	312.50	312.50	625.00	625.00	625.00	708.30	354.20	666.70	666.70	666.70	666.70
		Maximum Size of Fuse or Breaker	500	1000	1000	450	450	1000	1000	1000	800	400	800	800	800	800

See Page 17 for Connection Diagrams D C C H H G G G F I E E E E

⓪ See chart on page 16, for number of leads per termination.

NOTE: Inputs and Outputs may be reversed; kVA capacity remains constant. All applications above bold face line are suitable for 50/60 Hz. All applications below bold face line are suitable for 60 Hz only. With larger kVA buck-boost units, it is necessary to utilize multiple conductors on the secondary (X) terminals as shown in the chart on page 16.



Buck-Boost Transformers

Section 7 | Wiring Diagrams

BUCK-BOOST WIRING DIAGRAMS ① - SINGLE PHASE

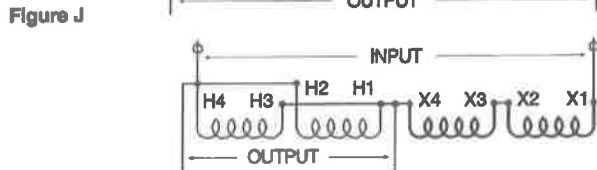
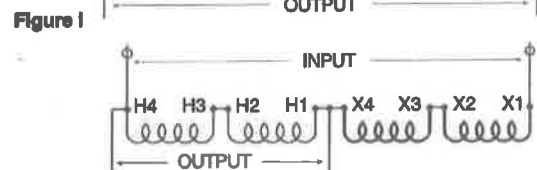
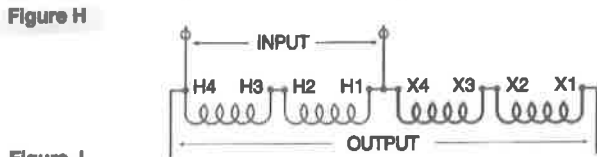
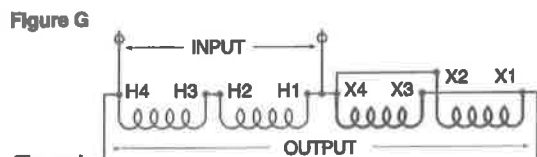
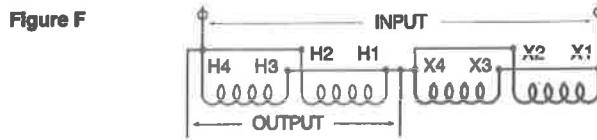
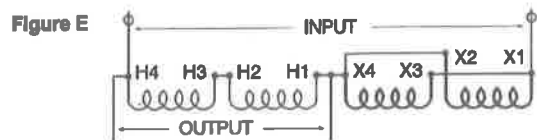
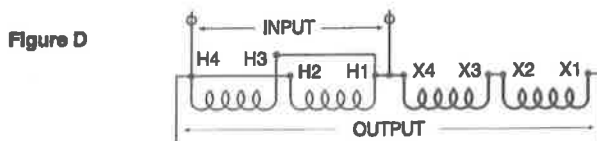
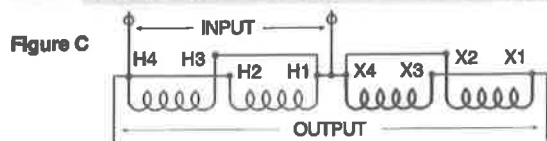

① The symbol O used in these connection diagrams indicates where to field install the over-current protective device, typically a fuse or circuit breaker.

BUCK-BOOST WIRING DIAGRAMS ① - SINGLE PHASE FOR THREE PHASE APPLICATIONS

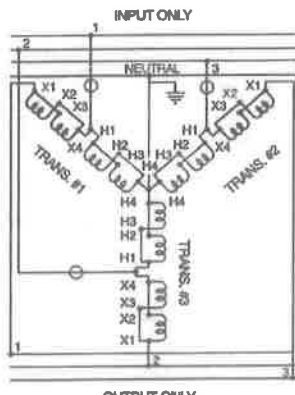

FIG. AA

WYE

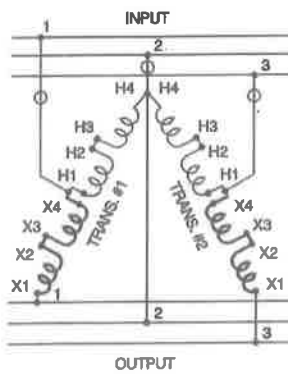

FIG. BB

OPEN DELTA

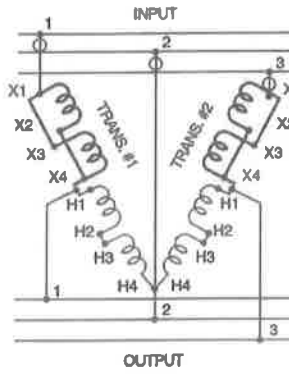

FIG. CC

OPEN DELTA

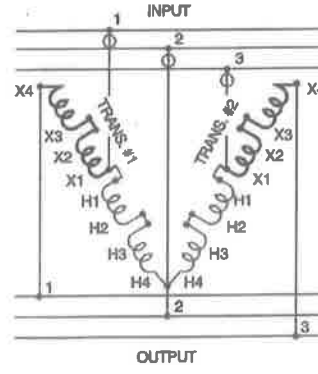

FIG. DD

OPEN DELTA

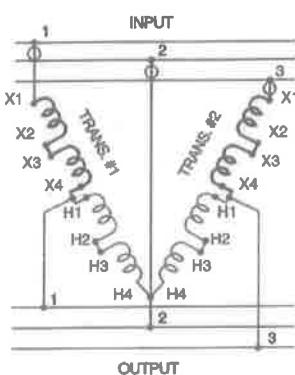

FIG. EE

OPEN DELTA

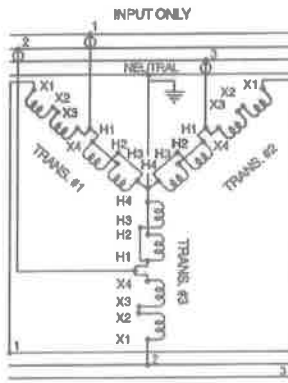

FIG. FF

WYE

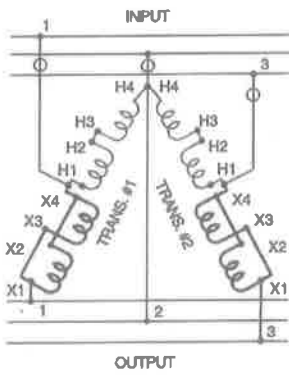

FIG. GG

OPEN DELTA

① The symbol O used in these connection diagrams indicates where to field install the over-current protective device, typically a fuse or circuit breaker.

② Cannot be reverse connected.

IMPORTANT: Refer to the N.E.C. (National Electrical Code) Article 450-4 for overcurrent protection of an autotransformer. These connection diagrams are packed with each buck-boost transformer. Do not use connections other than those shown above.

Jake Hankins

From: rzamora@tuluminnoveng.com <rzamora@tuluminnoveng.com>
Sent: Tuesday, February 6, 2024 10:18 AM
To: Robert Arntz; Cole Azamar; Jake Hankins
Cc: Rafael Reyes
Subject: Roll up door - testing

Rafael and I were on site yesterday with your roll up door contractor. After attempting several set ups, we tested using a generator with 240V, 30A and #6 wire. The door appeared to rise at his desired rate of speed with a draw of 13Amps. We then did another set up with 208V, 20A and #12 wire and 208V, 20A and #8 wire directly from the panelboard. Both had the same rise rate of speed and 6.6Amps.

Regards,

-Z

OAKLAND UNIFIED SCHOOL DISTRICT
CLAREMONT MS MULTI-PURPOSE & KITCHEN BUILDING
PROJ # 15127

CCR#139 ABI FILE 129 - SET UP TRANSFORMERS FOR VERTICAL LIFT DOORS

To: M. TORRES/CM; . CHENDERSON
From: Emil Vinuya, PE/Chief Cost Estimator
Date: 10-Jul-24

General Comments:

1 GENERAL CONTRACTOR: ARNTZ BUILDERS, INC.

No work provided by GC.

2 SUBCONTRACTOR: TULUM

Production rates appear reasonable per NECA.

Materials prices provided by Sub appears reasonable based on quotes from local supplier - Rexel.

3 GENERAL CONTRACTOR's COST PROPOSALS \$ 7,733.11

ESTIMATED CONSTRUCTION COST FOR CCR#139 \$ 7,733.11

COST ESTIMATE SUMMARY

Project Name: OAKLAND UNIFIED SCHOOL DISTRICT **Project Number:** 15127
CCR#124 CLAREMONT MS MULTI-PURPOSE & KITCHEN BUILDING **Date:** 10-Jul-24
 Oakland, CA

Decription : CCR#139
 ABI FILE 129 - SET UP TRANSFORMERS FOR VERTICAL LIFT DOORS

Reference Drawing: Cost Proposal dated 6/12/2024
SUBCONTRACTOR: TULUM

	Total Labor	B) Total Material Costs	C) Total Rental Equipment Cost	TOTAL
1	SHEET 1 of 2			
2	SHEET 2 of 2			
3	\$ 5,598.82	\$ 994.57	\$ -	\$ 6,593.39
4				
5				
6				
7	\$ 5,598.82	+ \$ 994.57	+ \$ -	= \$ 6,593.39
8				
9	Expenses:			
10	Material Sales Tax.....		10.25% of Total Material:	\$ 101.94
11	Rental Sales Tax.....		10.25% of Total Rental:	\$ -
12				
13			Subtotal - Line 7 thru 12:	\$ 6,695.34
14				
15	General Contractor OH, B&IP, &P:		10.00% * Total Cost	\$ 669.53
19			*(Overhead, Bond & Insurance Premiums & Profit)	
20				
21			Subtotal - Line 13 thru 19:	\$ 7,364.87
22				
23			Sub-Subcontractor's Cost - None	\$ -
24				
25			SUBTOTAL	\$ -
26	General Contractor OH&P on Sub Cost:		5.00% *	\$ -
27				
28			TOTAL PROBABLE CONSTRUCTION COST - TULUM	\$ 7,364.87

OAKLAND UNIFIED SCHOOL DISTRICT

Division of Facilities Planning and Management • 955 High Street Oakland, California 94601 • Phone 510/535-2728 • Fax 510/535-7040

(Proposed Change Order) No. 8

PROJECT: Claremont Middle School MPR & Kitchen Project

DATE: OCTOBER 30, 2024

OWNER: OAKLAND UNIFIED SCHOOL DISTRICT

DSA FILE NO.: 01-119337

CONTRACTOR: ARNTZ BUILDERS INC.

DSA APP NO.: 01-119337

431 Payran

OUSD PROJECT #: 15127

Petaluma, CA 94952

PROJECT MANAGER: JaQuan Cornish

Contractor hereby submits this Change Order Request ("COR") pursuant to the contract documents, including but not limited to General Conditions sections 4.5.1, 4.5.2, 7.6, 7.7, 8.4.1, and 8.4.2.

DESCRIPTION OF PROPOSED CHANGES IN WORK (specifically refer to attached pages or incorporated documents): **PCO 143 – Gutters at (E) Gym Canopy (Unforeseen):** Costs associated with the gutters that were added to the roof of the (E) gym canopy. Detail was not reflected in the project drawings.

OTHER PROPOSED CHANGES TO THE CONTRACT:

PCOs: #27, #58, #75, #97, #120, #128, #139, #144 & #146

PROPOSED ADJUSTMENT TO CONTRACT PRICE: \$1,827

PROPOSED ADJUSTMENT TO CONTRACT TIME: 0 calendar days

REASON FOR REQUEST (check one or more):

- Unforeseen Conditions
- Direction by Government Agency
- Owner Requested
- Design Omission
- Design Error
- Other: _____

OAKLAND UNIFIED SCHOOL DISTRICT

Division of Facilities Planning and Management • 955 High Street Oakland, California 94601 • Phone 510/535-2728 • Fax 510/535-7040

CERTIFICATION

I, Robert Arntz [name of declarant], declare the following:

Arntz Builders Inc. [Contractor company name] has contracted with Oakland Unified School District [public entity name] for the Claremont Middle School MPR & Kitchen Contract ("Contract"). Arntz Builders Inc. [Contractor company name] authorized me to prepare the attached Change Order Request ("COR") for money and/or time extension for Oakland Unified School District [public entity name] regarding this Contract (such COR being dated October 30, 2024, and entitled Change Order 1 and requesting \$2,153.35 and/or 0 additional days), and I prepared the attached COR. I am the most knowledgeable person at Arntz Builders Inc. [Contractor company name] regarding this COR.

The attached COR complies with all laws applicable to submission of a COR, including but not limited to California Penal Code section 72, Government Code sections 12650 et seq. (False Claims Act), and Business and Professions Code sections 17200 et seq. (Unfair Business Practices Act). I am aware that submission or certification of false claims, or other claims that violate law or the Contract, may lead to fines, imprisonment, and/or other serious legal consequences for myself or Arntz Builders [Contractor company name].

The attached COR does not breach the Contract, is not a false claim, does not violate any applicable law, satisfies all provisions of the Contract applicable to submission of the COR, only contains truthful and accurate supporting data, and only requests money and/or time extensions that accurately reflect the adjustments to money and time for which I believe that Oakland Unified School District [public entity name] is responsible under its Contract with Arntz Builders Inc. [Contractor company name].

While preparing this declaration and COR I consulted with others (including attorneys, consultants, or others who work for Arntz Builders Inc. [Contractor company name]) when necessary to ensure that the statements were true and correct.

Contractor understands and agrees that any COR submitted without this certification does not meet the terms of the Contract Documents; that Owner, or Owner's representatives, may reject the COR on that basis; and that unless Contractor properly and timely files the COR with the certification, Contractor cannot further pursue the COR in any forum and all rights to additional money or time for the issues covered by the COR are waived due to a condition precedent not having been satisfied.

I declare under the penalty of perjury under the laws of the State of California that the foregoing is true and correct. Executed October 30, 2024, at Oakland, California.

 [signature]

Robert Arntz [name of declarant]



Arntz Builders, Inc.

431 Payran St, Petaluma CA 94952 License No. 856393 T (707) 835-2900 F (707) 835-2993 www.arntzbuilders.com

Date: 6/12/24

Project Name: 2205 Claremont MS MPR & Kitchen

Generating Document: (E) Gym Canopy

Arntz File #: 143

Arntz File Title: Gutters at (E) Gym Canopy

NOTIFICATION OF EXTRA:

The above referenced issue constitutes a changed condition resulting in extra work and extra costs. This condition will impact the project schedule.

Scope Change: Costs associated with the gutters that were added to the roof of the (E) gym canopy not shown in the project drawings.

Location: (E) Gym Canopy



Arntz Builders, Inc.

431 Payran St, Petaluma CA 94952 License No. 856393 T (707) 835-2900 F (707) 835-2993 www.arntzbuilders.com

July 1, 2024

Oakland Unified School District
1000 Broadway, Ste 300
Oakland, CA 94607

Subject : **Claremont MS New Multi-Purpose and Kitchen**
File No. 143 Gutters at (E) Gym Canopy

Good Afternoon,

Costs associated with the gutters that were added to the roof of the (E) gym canopy, which are not shown in the project drawings.

Subcontractor Work:

Westech		<u>\$1,740.00</u>
Subcontractor Subtotal		<u>\$1,740.00</u>
Mark-Up	5.0%	<u>\$87.00</u>

TOTAL QUOTE **\$1,827.00**

We reserve the right to submit a claim for an extension of time and for all related delay and inefficiency costs that may result due to the changed condition. The extent and amount will be determined at a later date when the full impact of changed condition can be evaluated and determined. All rights and remedies are reserved.

Sincerely,

ARNTZ BUILDERS

Robert Arntz
Project Manager

cc:
ST
enc

OAKLAND UNIFIED SCHOOL DISTRICT
CLAREMONT MS MULTI-PUROSE & KITCHEN BUILDING
PROJ # 15127
CCR#143 ABI FILE 143 GUTTERS AT € GYM CANOPY

To: M. TORRES/CM; C. HENDERSON/PE
From: Emil Vinuya, PE/Chief Cost Estimator
Date: 11-Jul-24

General Comments:

1 GENERAL CONTRACTOR: ARNTZ BUILDERS, INC.

No work performed by GC.

2 SUBCONTRACTOR: WESTECH

Cost proposed by Sub appears reasonable.

3 GENERAL CONTRACTOR'S COST PROPOSALS

\$ 1,827.00

ESTIMATED CONSTRUCTION COST FOR CCR#143

\$ 1,827.00

COST ESTIMATE SUMMARY

Project Name:	OAKLAND UNIFIED SCHOOL DISTRICT CLAREMONT MS MULTI-PUROSE & KITCHEN BUILDING Oakland, CA	Project Number:	15127
		Date:	11-Jul-24

Decription : **CCR#143**
ABI FILE 143 GUTTERS AT € GYM CANOPY

Reference Drawing: **Cost Proposal dated 07/1/2024**
SUBCONTRACTOR: **WESTECH**

	Total Labor	B) Total Material Costs	C) Total Rental Equipment Cost	TOTAL
1	SHEET 1 of 2			
2	SHEET 2 of 2			
3	\$ 1,304.348	\$ 189.00	\$ -	\$ 1,493.35
4				
5				
6				
7	\$ 1,304.35	+ \$ 189.00	+ \$ -	= \$ 1,493.35
8				
9	Expenses:			
10	Material Sales Tax.....		10.25% of Total Material:	\$ 19
11	Rental Sales Tax.....		10.25% of Total Rental:	Incl.
12				
13			Subtotal - Line 7 thru 12:	\$ 1,512.72
14				
15	General Contractor OH, B&IP, &P:		15.00% * Total Cost	\$227
19			*(Overhead, Bond & Insurance Premiums & Profit)	
20				
21			Subtotal - Line 13 thru 19:	\$ 1,739.63
22				
23			Subcontractor's Cost - None	\$ -
24			SUBTOTAL	\$ -
25	General Contractor OH&P on Sub Cost:		5.00% *	\$ -
26				
27			TOTAL PROBABLE CONSTRUCTION COST - WESTECH	\$ 1,739.63

OAKLAND UNIFIED SCHOOL DISTRICT

Division of Facilities Planning and Management • 955 High Street Oakland, California 94601 • Phone 510/535-2728 • Fax 510/535-7040

(Proposed Change Order) No. 9

PROJECT: Claremont Middle School MPR & Kitchen Project

DATE: OCTOBER 30, 2024

OWNER: OAKLAND UNIFIED SCHOOL DISTRICT

DSA FILE NO.: 01-119337

CONTRACTOR: ARNTZ BUILDERS INC.

DSA APP NO.: 01-119337

431 Payran

OUSD PROJECT #: 15127

Petaluma, CA 94952

PROJECT MANAGER: JaQuan Cornish

Contractor hereby submits this Change Order Request ("COR") pursuant to the contract documents, including but not limited to General Conditions sections 4.5.1, 4.5.2, 7.6, 7.7, 8.4.1, and 8.4.2.

DESCRIPTION OF PROPOSED CHANGES IN WORK (specifically refer to attached pages or incorporated documents): **PCO 144 – Added Signage Type S19 (Omission):** Required signage type S19 was added in ASI 27, resulting in additional costs.

OTHER PROPOSED CHANGES TO THE CONTRACT:

PCOs: #27, #58, #75, #97, #120, #128, #139, #143 & #146

PROPOSED ADJUSTMENT TO CONTRACT PRICE: \$1,359.13

PROPOSED ADJUSTMENT TO CONTRACT TIME: 0 calendar days

REASON FOR REQUEST (check one or more):

- Unforeseen Conditions
- Direction by Government Agency
- Owner Requested
- Design Omission
- Design Error
- Other: _____

OAKLAND UNIFIED SCHOOL DISTRICT

Division of Facilities Planning and Management • 955 High Street Oakland, California 94601 • Phone 510/535-2728 • Fax 510/535-7040

CERTIFICATION

I, Robert Arntz [name of declarant], declare the following:

Arntz Builders Inc. [Contractor company name] has contracted with Oakland Unified School District [public entity name] for the Claremont Middle School MPR & Kitchen Contract ("Contract"). Arntz Builders Inc. [Contractor company name] authorized me to prepare the attached Change Order Request ("COR") for money and/or time extension for Oakland Unified School District [public entity name] regarding this Contract (such COR being dated October 30, 2024, and entitled Change Order 1 and requesting \$2,153.35 and/or 0 additional days), and I prepared the attached COR. I am the most knowledgeable person at Arntz Builders Inc. [Contractor company name] regarding this COR.

The attached COR complies with all laws applicable to submission of a COR, including but not limited to California Penal Code section 72, Government Code sections 12650 et seq. (False Claims Act), and Business and Professions Code sections 17200 et seq. (Unfair Business Practices Act). I am aware that submission or certification of false claims, or other claims that violate law or the Contract, may lead to fines, imprisonment, and/or other serious legal consequences for myself or Arntz Builders [Contractor company name].

The attached COR does not breach the Contract, is not a false claim, does not violate any applicable law, satisfies all provisions of the Contract applicable to submission of the COR, only contains truthful and accurate supporting data, and only requests money and/or time extensions that accurately reflect the adjustments to money and time for which I believe that Oakland Unified School District [public entity name] is responsible under its Contract with Arntz Builders Inc. [Contractor company name].

While preparing this declaration and COR I consulted with others (including attorneys, consultants, or others who work for Arntz Builders Inc. [Contractor company name]) when necessary to ensure that the statements were true and correct.

Contractor understands and agrees that any COR submitted without this certification does not meet the terms of the Contract Documents; that Owner, or Owner's representatives, may reject the COR on that basis; and that unless Contractor properly and timely files the COR with the certification, Contractor cannot further pursue the COR in any forum and all rights to additional money or time for the issues covered by the COR are waived due to a condition precedent not having been satisfied.

I declare under the penalty of perjury under the laws of the State of California that the foregoing is true and correct. Executed October 30, 2024, at Oakland, California.

 [signature]

Robert Arntz [name of declarant]



Arntz Builders, Inc.

431 Payran St, Petaluma CA 94952 License No. 856393 T (707) 835-2900 F (707) 835-2993 www.arntzbuilders.com

Date: 6/21/24

Project Name: Claremont MS MPR & Kitchen

Generating Document: ASI 27

Arntz File #: 144

Arntz File Title: Added Signage Type S19

NOTIFICATION OF EXTRA:

The above referenced issue constitutes a changed condition resulting in extra work and extra costs. This condition will impact the project schedule.

Scope Change: Signage type S19 was added in ASI 27, which results in additional costs.

Location: MPR Buildings



Arntz Builders, Inc.

431 Payran St, Petaluma CA 94952 License No. 856393 T (707) 835-2900 F (707) 835-2993 www.amtzbuilders.com

July 1, 2024

Oakland Unified School District

1000 Broadway, Ste 300
Oakland, CA 94607

Subject : Claremont MS New Multi-Purpose and Kitchen
File No. 144 Added Signage Type S19

Good Afternoon,

Signage type S19 was added in ASI 27, which results in additional costs.

Subcontractor Work:

A Good Sign		\$1,294.41
Subcontractor Subtotal		<u>\$1,294.41</u>
Mark-Up	5.0%	<u>\$64.72</u>

TOTAL QUOTE **\$1,359.13**

We reserve the right to submit a claim for an extension of time and for all related delay and inefficiency costs that may result due to the changed condition. The extent and amount will be determined at a later date when the full impact of changed condition can be evaluated and determined. All rights and remedies are reserved.

Sincerely,

ARNTZ BUILDERS

Robert Arntz
Project Manager

cc:
ST
enc

S MEEK ARCHITECTURE

OUSD Claremont MS Multi-purpose Bldg & Kitchen DSA Application # 01-119337	ASI 27	Date: 6/17/2024
--	---------------	---------------------------

Architectural Supplemental Instructions: Door number signs

Project Owner:	Architect:	General Contractor:
Oakland Unified School District 955 High Street Oakland, CA 94601 Attn: Mike Torres	S Meek Architecture 3040 24 th Street San Francisco, CA 94110 Attn: Susannah Meek	Arntz Builders, Inc. 431 Payran Street Petaluma, CA 94952 Attn: Jake Hankins

General: The following instructions, substitutions, alterations, changes, clarifications, additions, and/or deletions are hereby made a part of the Contract Documents and modify the original Documents approved by DSA 1/22/2022. All other conditions shall remain the same. Unless otherwise stated in writing to the Owner, proceeding with the work described in this Architect's Supplemental Instruction (ASI) or CCD (Construction Change Directive) indicates the General Contractor's acknowledgement that there will be no change in the Contract Sum or Contract Time.

Description of Work:

Add the following sign TYPE to the project "S19". This will be a room number sign.

Documents Issued / Attachments:

"S19" sign type to be a room number sign as depicted. Size to be 1 1/2" x max width of 6" (if length longer than 4" is needed to fit text)

Provide and install this sign:

- @ door 202 with text message "ROOM 2"
- @ door 301 with text message "ROOM 3"
- @ door 401 with text message "ROOM 4"
- @ door 601 with text message "ROOM 6"
- @ door 111 with text message "ROOM 11"
- @ door 130 with text message "ROOM 13A"
- @ door 303 with text message "ROOM 3A"

Install this sign to top of door frames with epoxy adhesive.

Background plastic color to be "3x-811 parchment" or sim.
Text lettering color to be "3x1-502 marine blue" or sim.

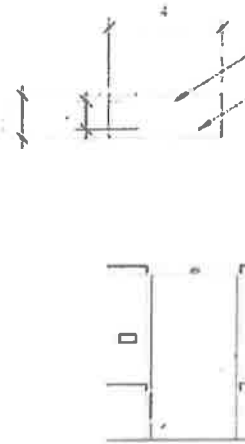

1" TALL CHARACTERS
SIGN THICKNESS: 0.125"
ACRYLIC
FABRICATED SIGN
NO VINYL LETTERING, NO PAINT;
CENTER SIGN ON DOOR FRAME

Basis for ASI Issue:

Clarification for fire department request

DSA Approval Required no yes
 Issued By: Susannah Meek, Architect, S Meek Architecture
 Distributed to: CM team
 Architect of Record: Susannah Meek, S Meek Architecture

OAKLAND UNIFIED SCHOOL DISTRICT
CLAREMONT MS MULTI-PUROSE & KITCHEN BUILDING
PROJ # 15127

CCR#144 ABI FILE 144 ADDED SIGNAGE TYPE S19

To: M. TORRES/CM; C. HENDERSON/PE
From: Emil Vinuya, PE/Chief Cost Estimator
Date: 11-Jul-24

General Comments:

1 GENERAL CONTRACTOR: ARNTZ BUILDERS, INC.

No work performed by GC.

2 SUBCONTRACTOR: A GOOD SIGN

Cost proposed by Sub appears reasonable.

3 GENERAL CONTRACTOR'S COST PROPOSALS

\$ 1,359.13

ESTIMATED CONSTRUCTION COST FOR CCR#144

\$ 1,359.13

COST ESTIMATE SUMMARY

Project Name:	OAKLAND UNIFIED SCHOOL DISTRICT CLAREMONT MS MULTI-PUROSE & KITCHEN BUILDING Oakland, CA	Project Number:	15127
		Date:	11-Jul-24

Decription : **CCR#144**
 ABI FILE 144 ADDED SIGNAGE TYPE S19

Reference Drawing: Cost Proposal dated 07/1/2024
 SUBCONTRACTOR: A GOOD SIGN

	Total Labor	B) Total Material Costs	C) Total Rental Equipment Cost	TOTAL
1	SHEET 1 of 2			
2	SHEET 2 of 2			
3	\$ 1,019.240	\$ 157.50	\$ -	\$ 1,176.74
4				
5				
6				
7	\$ 1,019.24	+ \$ 157.50	+ \$ -	= \$ 1,176.74
8				
9	Expenses:			
10	Material Sales Tax.....		10.25% of Total Material:	Incl.
11	Rental Sales Tax.....		10.25% of Total Rental:	Incl.
12				
13			Subtotal - Line 7 thru 12:	\$ 1,176.74
14				
15	General Contractor OH, B&IP, &P:		10.00% * Total Cost	\$118
19			*(Overhead, Bond & Insurance Premiums & Profit)	
20				
21			Subtotal - Line 13 thru 19:	\$ 1,294.41
22				
23			Subcontractor's Cost - None	\$ -
24			SUBTOTAL	\$ -
25	General Contractor OH&P on Sub Cost:		5.00% *	\$ -
26				
27			TOTAL PROBABLE CONSTRUCTION COST - A GOOD SIGN	\$ 1,294.41

OAKLAND UNIFIED SCHOOL DISTRICT

Division of Facilities Planning and Management • 955 High Street Oakland, California 94601 • Phone 510/535-2728 • Fax 510/535-7040

(Proposed Change Order) No. 10

PROJECT: Claremont Middle School MPR & Kitchen Project

DATE: OCTOBER 30, 2024

DSA FILE NO.: 01-119337

OWNER: OAKLAND UNIFIED SCHOOL DISTRICT

DSA APP NO.: 01-119337

CONTRACTOR: ARNTZ BUILDERS INC.

OUSD PROJECT #: 15127

431 Payran

PROJECT MANAGER: JaQuan Cornish

Petaluma, CA 94952

Contractor hereby submits this Change Order Request ("COR") pursuant to the contract documents, including but not limited to General Conditions sections 4.5.1, 4.5.2, 7.6, 7.7, 8.4.1, and 8.4.2.

DESCRIPTION OF PROPOSED CHANGES IN WORK (specifically refer to attached pages or incorporated documents): **PCO 146 – Replace Gym FA Devices (Unforeseen):** Per Enrico with OUSD Fire Alarm Shop and Johnson Control Inc., the replacement of Fire Alarm devices in the old gym is required resulting in an additional cost.

OTHER PROPOSED CHANGES TO THE CONTRACT:

PCOs: #27, #58, #75, #97, #120, #128, #139, #143 & #144

PROPOSED ADJUSTMENT TO CONTRACT PRICE: **\$10,567.26**

PROPOSED ADJUSTMENT TO CONTRACT TIME: 0 calendar days

REASON FOR REQUEST (check one or more):

- Unforeseen Conditions
- Direction by Government Agency
- Owner Requested
- Design Omission
- Design Error
- Other: _____

OAKLAND UNIFIED SCHOOL DISTRICT

Division of Facilities Planning and Management • 955 High Street Oakland, California 94601 • Phone 510/535-2728 • Fax 510/535-7040

CERTIFICATION

I, Robert Arntz [name of declarant], declare the following:

Arntz Builders Inc. [Contractor company name] has contracted with Oakland Unified School District [public entity name] for the Claremont Middle School MPR & Kitchen Contract ("Contract"). Arntz Builders Inc. [Contractor company name] authorized me to prepare the attached Change Order Request ("COR") for money and/or time extension for Oakland Unified School District [public entity name] regarding this Contract (such COR being dated October 30, 2024, and entitled Change Order 1 and requesting \$2,153.35 and/or 0 additional days), and I prepared the attached COR. I am the most knowledgeable person at Arntz Builders Inc. [Contractor company name] regarding this COR.

The attached COR complies with all laws applicable to submission of a COR, including but not limited to California Penal Code section 72, Government Code sections 12650 et seq. (False Claims Act), and Business and Professions Code sections 17200 et seq. (Unfair Business Practices Act). I am aware that submission or certification of false claims, or other claims that violate law or the Contract, may lead to fines, imprisonment, and/or other serious legal consequences for myself or Arntz Builders [Contractor company name].

The attached COR does not breach the Contract, is not a false claim, does not violate any applicable law, satisfies all provisions of the Contract applicable to submission of the COR, only contains truthful and accurate supporting data, and only requests money and/or time extensions that accurately reflect the adjustments to money and time for which I believe that Oakland Unified School District [public entity name] is responsible under its Contract with Arntz Builders Inc. [Contractor company name].

While preparing this declaration and COR I consulted with others (including attorneys, consultants, or others who work for Arntz Builders Inc. [Contractor company name]) when necessary to ensure that the statements were true and correct.

Contractor understands and agrees that any COR submitted without this certification does not meet the terms of the Contract Documents; that Owner, or Owner's representatives, may reject the COR on that basis; and that unless Contractor properly and timely files the COR with the certification, Contractor cannot further pursue the COR in any forum and all rights to additional money or time for the issues covered by the COR are waived due to a condition precedent not having been satisfied.

I declare under the penalty of perjury under the laws of the State of California that the foregoing is true and correct. Executed October 30, 2024, at Oakland, California.

 [signature]

Robert Arntz [name of declarant]



Arntz Builders, Inc.

431 Payran St, Petaluma CA 94952 License No. 856393 T (707) 835-2900 F (707) 835-2993 www.arntzbuilders.com

Date: 8/19/24

Project Name: 2205 Claremont MS MPR & Kitchen

Generating Document: OUSD Direction

Arntz File #: 146

Arntz File Title: Replace Gym FA Devices

NOTIFICATION OF EXTRA:

The above referenced issue constitutes a changed condition resulting in extra work and extra costs. This condition will impact the project schedule.

Scope Change: Per Enrico with OUSD Fire Alarm Shop, the replacement of FA devices in the old gym is required. This is an additional cost.

Location: Existing Gym Building



Arntz Builders, Inc.

431 Payran St, Petaluma CA 94952 License No. 856393 T (707) 835-2900 F (707) 835-2993 www.amtzbuilders.com

August 19, 2024

Oakland Unified School District
1000 Broadway, Ste 300
Oakland, CA 94607

Subject : Claremont MS New Multi-Purpose and Kitchen
File No. 146 Replace Gym FA Devices

Good Afternoon,

Per Enrico with OUSD Fire Alarm Shop, the replacement of FA devices in the old gym is required. This is an additional cost.

Subcontractor Work:

Tulum Systems		<u>\$10,072.63</u>
Subcontractor Subtotal		<u>\$10,072.63</u>
Mark-Up	5.0%	<u>\$503.63</u>

TOTAL QUOTE **\$10,576.26**

We reserve the right to submit a claim for an extension of time and for all related delay and inefficiency costs that may result due to the changed condition. The extent and amount will be determined at a later date when the full impact of changed condition can be evaluated and determined. All rights and remedies are reserved.

Sincerely,

ARNTZ BUILDERS

Robert Arntz
Project Manager

cc:
ST
enc



Change Order Proposal

Johnson Controls Fire Protection
6952 Preston Ave

Tel. No: 925-273-0100

Date: 08/08/2024

Customer: Tulum Systems
Customer Tel. No: 000-000-0000
Customer Fax. No:

Project: OUSD Claremont Multi-Purpose &

Customer PO/Cont No. _____
Customer RFP Number _____

Johnson Controls Contract No: 650058476
Johnson Controls CO No: CO-FA-005
Johnson Controls RFI No: _____
Contract Extension in days: _____

It is hereby agreed the changes and additions in the Scope of Work noted below shall constitute an Extra to the contract in the amount noted on this form.

The sum shall be added to the original value of the above numbered contract and at Extras heretofore approved.

Change Order Description: CO 05

Scope Of the Work:

Johnson controls to provide the following parts that were identified as being needed for the gym at OUSD Claremont, the below includes, design, comm labor, and coordination labor.

14 49SO-APPLW
5 4906-9127
1-4906-9131

Material total: \$2455.00 + 10.25% tax 251.64

8 COMM HOURS X 301
4 Design hours x 295
4 coordination hours x 295

Total: \$4768.00

Price of the Work: \$7,474.64

The above price includes all applicable taxes Yes No

All work performed hereunder shall be in accordance with the terms and conditions of the base contract in effect as to the day of this proposal.

Customer Signature
Signature _____
Name: _____
Title: _____

Johnson Controls Signature
Signature _____
Name: Gabriel Rodriguez
Title: Operations Manager

OAKLAND UNIFIED SCHOOL DISTRICT
CLAREMONT MS MULTI-PURPOSE & KITCHEN BUILDING
PROJ # 15127
CCR#146 ABI FILE 146 - REPLACE GYM FA DEVICES

To: C. HENDERSON/PROJECT ENGINEER
From: Emil Vinuya, PE/Chief Cost Estimator
Date: 28-Aug-24

General Comments:

1 GENERAL CONTRACTOR: ARNTZ BUILDERS, INC.

No work provided by GC.

2 SUBCONTRACTOR: TULUM

Cost proposed by Sub appears reasonable

3 SUB-SUBCONTRACTOR: JCI

Materials prices provided by Sub appears reasonable based on quotes provided.

4 GENERAL CONTRACTOR's COST PROPOSALS \$ 10,576.26

ESTIMATED CONSTRUCTION COST FOR CCR#146 \$ 10,576.26

COST ESTIMATE SUMMARY

Project Name:	OAKLAND UNIFIED SCHOOL DISTRICT	Project Number:	15127
CCR#124	CLAREMONT MS MULTI-PURPOSE & KITCHEN BUILDING	Date:	28-Aug-24
	Oakland, CA		

Decription : CCR#146
 ABI FILE 146 - REPLACE GYM FA DEVICES

Reference Drawing: Cost Proposal dated 8/19/2024
 SUBCONTRACTOR: TULUM

	Total Labor	B) Total Material Costs	C) Total Rental Equipment Cost	TOTAL
1	SHEET 1 of 2			
2	SHEET 2 of 2			
3	\$ 2,022.06	\$ -	\$ -	\$ 2,022.06
4				
5				
6				
7	\$ 2,022.06	+ \$ -	+ \$ -	= \$ 2,022.06
8				
9	Expenses:			
10	Material Sales Tax.....		10.25% of Total Material:	\$ -
11	Rental Sales Tax.....		10.25% of Total Rental:	\$ -
12				
13			Subtotal - Line 7 thru 12:	\$ 2,022.06
14				
15	General Contractor OH, B&IP, &P:		10.00% * Total Cost	\$ 202.21
19			*(Overhead, Bond & Insurance Premiums & Profit)	
20				
21			Subtotal - Line 13 thru 19:	\$ 2,224.27
22				
23			Sub-Subcontractor's Cost - JCI	\$ 7,474.64
24				
25			SUBTOTAL	\$ 7,474.63
26	General Contractor OH&P on Sub Cost:		5.00% *	\$ 373.73
27				
28			TOTAL PROBABLE CONSTRUCTION COST - TULUM	\$ 10,072.62

COST ESTIMATE SUMMARY

Project Name:	OAKLAND UNIFIED SCHOOL DISTRICT	Project Number:	15127
CCR#124	CLAREMONT MS MULTI-PURPOSE & KITCHEN BUILDING	Date:	28-Aug-24
	Oakland, CA		

Decription : CCR#146
ABI FILE 146 - REPLACE GYM FA DEVICES

Reference Drawing: Cost Proposal dated 8/19/2024
SUBCONTRACTOR: JCI

	Total Labor	B) Total Material Costs	C) Total Rental Equipment Cost	TOTAL
1	SHEET 1 of 2			
2	SHEET 2 of 2			
3	\$ 4,768.00	\$ 2,455.00	\$ -	\$ 7,223.00
4				
5				
6				
7	\$ 4,768.00	+ \$ 2,455.00	+ \$ -	= \$ 7,223.00
8				
9	Expenses:			
10	Material Sales Tax.....		10.25% of Total Material:	\$ 251.64
11	Rental Sales Tax.....		10.25% of Total Rental:	\$ -
12				
13			Subtotal - Line 7 thru 12:	\$ 7,474.64
14				
15	General Contractor OH, B&IP, &P:	15.00% *	Total Cost	Incl.
19	*(Overhead, Bond & Insurance Premiums & Profit)			
20				
21			Subtotal - Line 13 thru 19:	\$ 7,474.64
22				
23			Sub-Subcontractor's Cost - JCI	\$ -
24				
25			SUBTOTAL	\$ -
26	General Contractor OH&P on Sub Cost:	5.00% *		\$ -
27				
28			TOTAL PROBABLE CONSTRUCTION COST - JCI	\$ 7,474.64

DIVISION OF FACILITIES PLANNING & MANAGEMENT ROUTING FORM

Project Information

Project Name	Claremont Middle School Multi-purpose Room & Kitchen	Site	201
---------------------	--	-------------	-----

Basic Directions

Services cannot be provided until the contract is awarded by the Board or is entered by the Superintendent pursuant to authority delegated by the Board.

Attachment Checklist	<input checked="" type="checkbox"/> Proof of general liability insurance, including certificates and endorsements, if contract is over \$15,000. <input checked="" type="checkbox"/> Workers compensation insurance certification, unless vendor is a sole provider
-----------------------------	--

Contractor Information

Contractor Name	ARNTZ BUILDERS, INC.	Agency's Contact	Brian Proteau				
OUSD Vendor ID #	000493	Title					
Street Address	431 Payran Street	City	Petaluma	State	CA	Zip	94952
Telephone	707-835-2900	Policy Expires					
Contractor History	Previously been an OUSD contractor? <input checked="" type="checkbox"/> Yes <input type="checkbox"/> No		Worked as an OUSD employee? <input type="checkbox"/> Yes <input checked="" type="checkbox"/> No				
OUSD Project #	15127						

Term of Original/Amended Contract

Date Work Will Begin (i.e., effective date of contract)	5-26-2022	Date Work Will End By (not more than 5 years from start date; for construction contracts, enter planned completion date)	
		New Date of Contract End (If Any)	10-18-2023

Compensation/Revised Compensation

If New Contract, Total Contract Price (Lump Sum)	\$	If New Contract, Total Contract Price (Not To Exceed)	\$
Pay Rate Per Hour (If Hourly)	\$	If Amendment, Change in Price	\$ 72,307.84
Other Expenses		Requisition Number	



Budget Information

If you are planning to multi-fund a contract using LEP funds, please contact the State and Federal Office before completing requisition.

Resource #	Funding Source	Org Key	Object Code	Amount
9655/9670	Fund 21, Measure Y	210-9655-0-9670-8500-6271-201-9180-9906-9999-15127	6271	\$72,307.84

Approval and Routing (in order of approval steps)

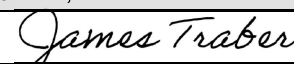
Services cannot be provided before the contract is fully approved and a Purchase Order is issued. Signing this document affirms that to your knowledge services were not provided before a PO was issued.

	Division Head	Phone	510-535-7038	Fax	510-535-7082
1.	Executive Director, Facilities				
	Signature 	Date Approved	Dec 4, 2024		
	<small>Preston Thomas (Dec 4, 2024 13:49 PST)</small>				
2.	General Counsel, Facilities				
	Signature 	Date Approved	11/27/2024		
3.	Chief Systems & Service Officer				
	Signature 	Date Approved	Dec 4, 2024		
	<small>Preston Thomas (Dec 4, 2024 13:49 PST)</small>				
4.	Chief Financial Officer				
	Signature	Date Approved			
5.	President, Board of Education				
	Signature	Date Approved			

Board Office Use: Legislative File Info.	
File ID Number	22-1167
Introduction Date	5-25-2022
Enactment Number	22/1235
Enactment Date	6/22/2022 os



OAKLAND UNIFIED
SCHOOL DISTRICT
Community Schools. Thriving Students

Memo (Bid Award)

To Board of Education

From Kyla Johnson-Trammell, Superintendent
 Adashi Nakadegawa, Deputy Chief, Division of Facilities Planning and Management

Board Meeting Date June 22, 2022

Subject Award of Agreement Between Owner and Contractor - Competitively Bid –Arntz Builders, Inc. – Claremont Middle School Multi-Purpose Room & Kitchen Project – Division of Facilities Planning & Management

Action Requested Approval by the Board of Education of Award of Agreement Between Owner and Contractor – by and between the **District and Arntz Builders, Inc.**, Petaluma, California (“Contractor”), for the latter to provide construction services which consist of constructing a Multi-purpose Building and Kitchen for the **Claremont Middle School Multi-Purpose Room & Kitchen Project**, in the amount of **\$15,985,725.00**, which includes a contingency allowance of **\$1,300,000.00**, as the lowest responsive bidder, with the work anticipated to commence on **June 23, 2022**, and scheduled to last for **Four Hundred Thirty-four (434)** Calendar days, with an anticipated ending of **August 31, 2023**.

Discussion The scope of work of the contract consists of the Claremont Middle School Multi-purpose Room & Kitchen Project. Contractor was selected through competitive bidding. (Public Contract Code § 22037).

LBP (Local Business Participation Percentage) 65.5%

Recommendation Approval by the Board of Education of Award of Agreement Between Owner and Contractor – by and between the **District and Arntz Builders, Inc.**, Petaluma, California (“Contractor”), for the latter to provide construction services which consist of constructing a Multi-purpose Building and Kitchen for the **Claremont Middle School Multi-Purpose Room & Kitchen Project**, in the amount of **\$15,985,725.00**, which includes a contingency allowance of **\$1,300,000.00**, as the lowest responsive bidder, with the work anticipated to commence on **June 23, 2022**, and scheduled to last for **Four Hundred Thirty-four (434)** Calendar days, with an anticipated ending of **August 31, 2023**.

Fiscal Impact Fund 21 Building Fund, Measure Y

Attachments

- Agreement
- Payment & Performance Bonds
- Insurance Certificate



CONTRACT JUSTIFICATION FORM

This Form Shall Be Submitted to the Board Office With Every Agenda Contract.

Legislative File ID No. 22-1167

Department: Facilities Planning and Management

Vendor Name: Arntz Builders, Inc.

Project Name: Claremont MS Multi-Purpose Room & Kitchen **Project No.:** 15127

Contract Term: Intended Start: 6-23-2022 Intended End: August 31, 2023

Total Cost Over Contract Term: \$15,985,725.00

Approved by: Tadashi Nakadegawa

Is Vendor a local Oakland Business or has it met the requirements of the

Local Business Policy? Yes (No if Unchecked)

How was this contractor or vendor selected?

Arntz Builders, Inc., was selected by the District as the lowest responsive and responsible bid.

Summarize the services or supplies this contractor or vendor will be providing.

Arntz Builders will construct a Multi-purpose Building and Kitchen on the Claremont Middle School Campus.

Was this contract competitively bid? Check box for “Yes” (If “No,” leave box unchecked)

If “No,” please answer the following questions:

1) How did you determine the price is competitive?

[Empty box for answer]

2) Please check the competitive bidding exception relied upon:

Construction Contract:

- Price is at or under UPCCAA threshold of \$60,000 (as of 1/1/19)
- CMAS contract [may only include “incidental work or service”] (Public Contract Code §§10101(a) and 10298(a)) – *contact legal counsel to discuss if applicable*
- Emergency contract (Public Contract Code §§22035 and 22050) – *contact legal counsel to discuss if applicable*
- No advantage to bidding (including sole source) – *contact legal counsel to discuss if applicable*
- Completion contract – *contact legal counsel to discuss if applicable*
- Lease-leaseback contract RFP process – *contact legal counsel to discuss if applicable*
- Design-build contract RFQ/RFP process – *contact legal counsel to discuss if applicable*
- Energy service contract – *contact legal counsel to discuss if applicable*
- Other: _____ – *contact legal counsel to discuss if applicable*

Consultant Contract:

- Architect, engineer, construction project manager, land surveyor, or environmental services – selected (a) based on demonstrated competence and professional qualifications (Government Code §4526), **and** (b) using a fair, competitive RFP selection process (Government Code §§4529.10 et seq.)
- Architect or engineer *when state funds being used* – selected (a) based on demonstrated competence and professional qualifications (Government Code §4526), (b) using a fair, competitive RFP selection process (Government Code §§4529.10 et seq.), **and** (c) using a competitive process consistent with Government Code §§4526-4528 (Education Code §17070.50)
- Other professional or specially trained services or advice – no bidding or RFP required (Public Contract Code §20111(d) and Government Code §53060) – *contact legal counsel to discuss if applicable*
- For services other than above, the cost of services is \$99,100 or less (as of 1/1/22)
- No advantage to bidding (including sole source) – *contact legal counsel to discuss if applicable*

Purchasing Contract:

- Price is at or under bid threshold of \$99,100 (as of 1/1/22)
- Certain instructional materials (Public Contract Code §20118.3)
- Data processing systems and supporting software – choose one of three lowest bidders (Public Contract Code §20118.1)

- Electronic equipment – competitive negotiation (Public Contract Code §20118.2) – *contact legal counsel to discuss if applicable*
- CMAS contract [may only include “incidental work or service”] (Public Contract Code §§10101(a) and 10298(a)) – *contact legal counsel to discuss if applicable*
- Piggyback contract for purchase of personal property (Public Contract Code §20118) – *contact legal counsel to discuss if applicable*
- Supplies for emergency construction contract (Public Contract Code §§22035 and 22050) – *contact legal counsel to discuss if applicable*
- No advantage to bidding (including sole source) – *contact legal counsel to discuss if applicable*
- Other: _____

Maintenance Contract:

- Price is at or under bid threshold of \$99,100 (as of 1/1/22)
- No advantage to bidding (including sole source) – *contact legal counsel to discuss*
- Other: _____

3) Explain in detail the facts that support the applicability of the exception marked above:

▪

AGREEMENT BETWEEN OWNER AND CONTRACTOR

This Agreement, effective June 23, 2022, is by and between the Oakland Unified School District, in Alameda County, California, hereinafter called the “Owner,” and ARNTZ BUILDERS, INC. hereinafter called the “Contractor.”

WITNESSETH: That the Contractor and the Owner for the consideration hereinafter named agree as follows:

ARTICLE I. SCOPE OF WORK. The Contractor agrees to furnish all labor, equipment and materials, including tools, implements, and appliances required, and to perform all the work required, by the Contract (the “Work”) in a good and workmanlike manner, free from any and all liens and claims from mechanics, material suppliers, subcontractors, artisans, machinists, teamsters, freight carriers, and laborers, and as specified in

the Claremont Middle School Multi-Purpose Room & Kitchen Project, **5750 College Avenue, Oakland, CA. 94618,**

all in strict compliance with the plans, drawings and specifications therefore prepared by

S MEEK ARCHITECTURE, 3040 24TH Street, San Francisco, CA 94110,
T: 415-543-5505

and other Contract Documents relating thereto.

The Contract as awarded includes the base scope of work only as specified in the Bid

During the Work, the Contractor shall ensure that all Work, including but not limited to Work performed by Subcontractors, is performed in compliance with all applicable legal, contractual, and local government requirements related to the novel coronavirus and COVID-19, including “social distancing,” masks, and hygiene as may be ordered by the State or local authorities and as may be directed in the Contract Documents.

ARTICLE II. CONTRACT DOCUMENTS. The Contractor and the Owner agree that all of the documents listed in Article 1.1.1 of the General Conditions form the “Contract Documents” which form the “Contract.” The Contractor and its subcontractors must use the Owner’s program software COLBI DOCS for projects.

ARTICLE III. TIME TO COMPLETE AND LIQUIDATED DAMAGES.

Time is of the essence in this Contract, and the time of Completion for the Work (“the Contract Time”) shall be Four hundred thirty-four (434) calendar days which shall start to run on (a) the date of commencement of the Work as established in the Owner’s Notice to Proceed, or (b) if no date of commencement is established in a Notice

to Proceed from Owner, the date of Contractor's actual commencement of the Work (including mobilization). The Owner anticipates that the Contract Time will start to run on June 23, 2022, in which case the deadline for Completion would be August 31, 2023.

The site for the Contract will not be available to the Contractor for construction on the following dates: N/A. The Contractor shall not be entitled to time extensions for lack of access to the site on these dates.

Failure to Complete the Work within the Contract Time and in the manner provided for by the Contract Documents, or failure to complete any specified portion of the Work by a milestone deadline, shall subject the Contractor to liquidated damages. The actual occurrence of damages and the actual amount of the damages which the Owner would suffer if the Work were not Completed within the Contract Time, or if any specified portion of the Work were not completed by a milestone deadline, are dependent upon many circumstances and conditions which could prevail in various combinations and, from the nature of the case, it is impracticable and extremely difficult to fix the actual damages. Damages which the Owner would suffer in the event of such delay include, but are not limited to, loss of the use of the Work, disruption of activities, costs of administration and supervision, third party claims, and the incalculable inconvenience and loss suffered by the public.

Accordingly, the parties agree that \$1,500,00 per calendar day of delay shall be the damages which the Owner shall directly incur upon failure of the Contractor to Complete the Work within the Contract Time or Complete any specified portion of the Work by a milestone deadline, as described above. Liquidated damages will accrue for failure to meet milestone deadlines even if the Contractor Completes the Work within the Contract Time.

In addition, Contractor shall be subject to liquidated damages, or actual damages if liquidated damages are not recoverable under law, for causing another contractor on the Project to fail to timely complete its work under its contract or for causing delayed *completion* of the Project. The actual occurrence of damages and the actual amount of the damages which the Owner would suffer if another contractor on the Project were to fail to timely complete its work under its contract or delay *completion* of the Project are dependent upon many circumstances and conditions which could prevail in various combinations and, from the nature of the case, it is impracticable and extremely difficult to fix the actual damages. Damages which the Owner would suffer in the event of such delay include, but are not limited to, loss of the use of the Work, loss of use of the other contractor's work, loss of use of the Project, disruption of activities, costs of administration and supervision, third party claims, the incalculable inconvenience and loss suffered by the public, and an Owner's inability to recover its delay damages from the contractors whose work was delayed by Contractor.

Accordingly, the parties agree that \$1,500.00 for each calendar day of delay shall be the amount of damages which the Owner shall directly incur upon Contractor causing another contractor on the Project to fail to timely complete its work under its contract or causing delayed *completion* of the Project.

For Contractor's obligations regarding claims against Owner from other contractors on the Project alleging that Contractor caused delays to their work, see General Conditions sections 3.7.4, 3.16 and 6.2.3.

If liquidated damages accrue as described above, the Owner, in addition to all other remedies provided by law, shall have the right to assess the liquidated damages at any time, and to withhold liquidated damages (and any interest thereon) at any time from any and all retention or progress payments, which would otherwise be or become due the Contractor. In addition, if it is reasonably apparent to the Owner before liquidated damages begin to accrue that they will accrue, Owner may assess and withhold, from retention or progress payments, the estimated amount of liquidated damages that will accrue in the future. If the retained percentage or withheld progress payments are not sufficient to discharge all liabilities of the Contractor incurred under this Article, the Contractor and its sureties shall continue to remain liable to the Owner until all such liabilities are satisfied in full.

If Owner accepts any work or makes any payment under the Contract Documents after a default by reason of delays, the payment or payments shall in no respect constitute a waiver or modification of any provision in the Contract Documents regarding time of Completion, milestone deadlines, or liquidated damages.

ARTICLE IV. PAYMENT AND RETENTION. The Owner agrees to pay the Contractor in current funds **FIFTEEN MILLION NINE HUNDRED EIGHTY-FIVE THOUSAND SEVEN HUNDRED TWENTY-FIVE DOLLARS NO/100 (\$15,985,725.00)** for work satisfactorily performed after receipt of properly documented and submitted Applications for Payment and to make payments on account thereof, as provided in the General Conditions.

The above contract price includes a general contingency allowance also known as a contingency allowance) of **ONE MILLION THREE HUNDRED THOUSAND DOLLARS NO/100 (\$1,300,000.00)** to pay any additional amounts to which the Contractor may be entitled under the Contract Documents other than special allowances.

Any payment from a special allowance or general contingency allowance ("Allowance") is entirely at the discretion, and only with the advanced written approval, of the Owner. To request payment from an Allowance, the Contractor must fully comply with the Contract Documents' requirements related to Notice to Potential Changes, Change Order Requests, and Claims, including but not limited to Articles 4 and 7 of the General Conditions and its provisions regarding waiver of rights for failure to comply. If the Owner approves in writing a payment from an Allowance, no change order approved by Owner's governing body shall be required, but Contractor must sign an Allowance expenditure form, after which the Contractor may include a request for such payment in its next progress payment application. Contractor's inclusion of a request for such payment in a progress payment application, or Contractor's acceptance of a progress payment that includes such payment, shall act as a full and complete waiver by Contractor of all rights to recover additional amounts, or to receive a time extension or

other consideration, related to the underlying basis of such payment; and such waiver shall be in addition to any other waiver that applies under the Contract Documents (including Article 4 of the General Conditions). If Contractor requests a time extension or other consideration in connection with or related to a requested payment from an Allowance, Contractor must comply with the Contract Documents' requirements related to Notice to Potential Changes, Change Order Requests, and Claims, including but not limited to Articles 4, 7, and 8 of the General Conditions and their provisions regarding waiver of rights for failure to comply, and no such time extension or other consideration may be issued until a change order is approved by the Owner's governing body pursuant to the Contract Documents. The amount of an Allowance may only be increased by a change order approved by Owner's governing body. Once an Allowance is fully spent, the Contractor must request any additional compensation pursuant to the procedures in the Contract Documents for Notices of Potential Claim, Change Order Requests, and Claims, and payment must be made by a change order approved by the Owner's governing body pursuant to the General Conditions. Upon Completion of the Work, all amounts in an Allowance that remain unspent and unencumbered shall remain the property of the Owner, Contractor shall have no claim to such funds, the Owner shall be entitled to a credit for such unused amounts against the above contract price, and the Owner may withhold such credit from any progress payment or release of retention.

ARTICLE V. CHANGES. Changes in this Agreement or in the Work to be done under this Agreement shall be made as provided in the General Conditions.

ARTICLE VI. TERMINATION. The Owner or Contractor may terminate the Contract as provided in the General Conditions.

ARTICLE VII. PREVAILING WAGES. The Project is a public work, the Work shall be performed as a public work and pursuant to the provisions of Section 1770 et seq. of the Labor Code of the State of California, which are hereby incorporated by reference and made a part hereof, the Director of Industrial Relations has determined the general prevailing rate of per diem wages and the general prevailing rate for holiday and overtime work in the locality in which the Work is to be performed, for each craft, classification or type of worker needed to execute this Contract. Per diem wages shall be deemed to include employer payments for health and welfare, pension, vacation, apprenticeship or other training programs, and similar purposes. Copies of the rates are on file at the Owner's principal office. The rate of prevailing wage for any craft, classification or type of workmanship to be employed on this Project is the rate established by the applicable collective bargaining agreement which rate so provided is hereby adopted by reference and shall be effective for the life of this Agreement or until the Director of the Department of Industrial Relations determines that another rate be adopted. It shall be mandatory upon the Contractor and on any subcontractor to pay not less than the said specified rates to all workers employed in the execution of this Agreement.

The Contractor and any subcontractor under the Contractor as a penalty to the Owner shall forfeit not more than Two Hundred Dollars (\$200.00) for each calendar day

Agreement over \$60,000 – Arntz Builders, Inc. – Claremont Middle School Multi-Purpose Room & Kitchen Project - \$15,985,725.00

or portion thereof for each worker paid less than the stipulated prevailing rates for such work or craft in which such worker is employed. The difference between such stipulated prevailing wage rates and the amount paid to each worker for each calendar day or portion thereof for which each worker was paid less than the stipulated prevailing wage rate shall be paid to each worker by the Contractor.

The Contractor and each Subcontractor shall keep or cause to be kept an accurate record for Work on this Contract and Project showing the names, addresses, social security numbers, work classification, straight time and overtime hours worked and occupations of all laborers, workers and mechanics employed by them in connection with the performance of this Contract or any subcontract thereunder, and showing also the actual per diem wage paid to each of such workers, which records shall be open at all reasonable hours to inspection by the Owner, its officers and agents and to the representatives of the Division of Labor Standards Enforcement of the State Department of Industrial Relations. The Contractor and each subcontractor shall furnish a certified copy of all payroll records directly to the Labor Commissioner.

Public works projects shall be subject to compliance monitoring and enforcement by the Department of Industrial Relations. For all projects over Twenty-Five Thousand Dollars (\$25,000), a contractor or subcontractor shall not be qualified to submit a bid or to be listed in a bid proposal subject to the requirements of Public Contract Code section 4104 unless currently registered and qualified under Labor Code section 1725.5 to perform public work as defined by Division 2, Part 7, Chapter 1 (§§1720 et seq.) of the Labor Code. For all projects over Twenty-Five Thousand Dollars (\$25,000), a contractor or subcontractor shall not be qualified to enter into, or engage in the performance of, any contract of public work (as defined by Division 2, Part 7, Chapter 1 (§§1720 et seq.) of the Labor Code) unless currently registered and qualified under Labor Code section 1725.5 to perform public work.

ARTICLE VIII. WORKING HOURS. In accordance with the provisions of Sections 1810 to 1815, inclusive, of the Labor Code of the State of California, which are hereby incorporated and made a part hereof, the time of service of any worker employed by the Contractor or a Subcontractor doing or contracting to do any part of the Work contemplated by this Agreement is limited and restricted to eight hours during any one calendar day and forty hours during any one calendar week, provided, that work may be performed by such employee in excess of said eight hours per day or forty hours per week provided that compensation for all hours worked in excess of eight hours per day, and forty hours per week, is paid at a rate not less than one and one-half (1½) times the basic rate of pay. The Contractor and every Subcontractor shall keep an accurate record showing the name of and the actual hours worked each calendar day and each calendar week by each worker employed by them in connection with the Work. The records shall be kept open at all reasonable hours to inspection by representatives of the Owner and the Division of Labor Law Enforcement. The Contractor shall as a penalty to the Owner forfeit Twenty-five Dollars (\$25.00) for each worker employed in the execution of this Agreement by the Contractor or by any subcontractor for each calendar day during which such worker is required or permitted to work more than eight hours in any one calendar

day, and forty hours in any one calendar week, except as herein provided.

ARTICLE IX. APPRENTICES. The Contractor agrees to comply with Chapter 1, Part 7, Division 2, Sections 1777.5 and 1777.6 of the California Labor Code, which are hereby incorporated and made a part hereof. These sections require that contractors and subcontractors employ apprentices in apprenticeable occupations in a ratio of not less than one hour of apprentice's work for each five hours of work performed by a journeyman (unless an exemption is granted in accordance with Section 1777.5) and that contractors and subcontractors shall not discriminate among otherwise qualified employees as indentured apprentices on any public works solely on the ground of sex, race, religious creed, national origin, ancestry or color. Only apprentices as defined in Labor Code Section 3077, who are in training under apprenticeship standards and who have signed written apprentice agreements, will be employed on public works in apprenticeable occupations. The responsibility for compliance with these provisions is fixed with the Contractor for all apprenticeable occupations.

ARTICLE X. DSA OVERSIGHT PROCESS. The Contractor must comply with the applicable requirements of the Division of State Architect ("DSA") Construction Oversight Process ("DSA Oversight Process"), including but not limited to (a) notifying the Owner's Inspector of Record/Project Inspector ("IOR") upon commencement and completion of each aspect of the Work as required under DSA Form 156; (b) coordinating the Work with the IOR's inspection duties and requirements; (c) submitting verified reports under DSA Form 6-C; and (d) coordinating with the Owner, Owner's Architect, any Construction Manager, any laboratories, and the IOR to meet the DSA Oversight Process requirements without delay or added costs to the Work or Project.

Contractor shall be responsible for any additional DSA fees related to review of proposed changes to the DSA-approved construction documents, to the extent the proposed changes were caused by Contractor's wrongful act or omissions. If inspected Work is found to be in non-compliance with the DSA-approved construction documents or the DSA-approved testing and inspection program, then it must be removed and corrected. Any construction that covers unapproved or uninspected Work is subject to removal and correction, at Contractor's expense, in order to permit inspection and approval of the covered work in accordance with the DSA Oversight Process.

ARTICLE XI. INDEMNIFICATION AND INSURANCE. The Contractor will defend, indemnify and hold harmless the Owner, its governing board, officers, agents, trustees, employees and others as provided in the General Conditions.

By this statement the Contractor represents that it has secured the payment of Workers' Compensation in compliance with the provisions of the Labor Code of the State of California and during the performance of the work contemplated herein will continue so to comply with said provisions of said Code. The Contractor shall supply the Owner with certificates of insurance evidencing that Workers' Compensation Insurance is in effect and providing that the Owner will receive thirty (30) days' notice of cancellation.

Contractor shall provide the insurance set forth in the General Conditions. The amount of general liability insurance shall be \$4,000,000 per occurrence for bodily injury, personal injury and property damage and the amount of automobile liability insurance shall be \$2,000,000 per accident for bodily injury and property damage combined single limit.

ARTICLE XII. ENTIRE AGREEMENT. The Contract constitutes the entire agreement between the parties relating to the Work, and supersedes any prior or contemporaneous agreement between the parties, oral or written, including the Owner's award of the Contract to Contractor, unless such agreement is expressly incorporated herein. The Owner makes no representations or warranties, express or implied, not specified in the Contract. The Contract is intended as the complete and exclusive statement of the parties' agreement pursuant to Code of Civil Procedure section 1856.

ARTICLE XIII. EXECUTION OF OTHER DOCUMENTS. The parties to this Agreement shall cooperate fully in the execution of any and all other documents and in the completion of any additional actions that may be necessary or appropriate to give full force and effect to the terms and intent of the Contract.

ARTICLE XIV. EXECUTION IN COUNTERPARTS. This Agreement may be executed in counterparts such that the signatures may appear on separate signature pages. A copy, or an original, with all signatures appended together, shall be deemed a fully executed Agreement.

ARTICLE XV. BINDING EFFECT. Contractor, by execution of this Agreement, acknowledges that Contractor has read this Agreement and the other Contract Documents, understands them, and agrees to be bound by their terms and conditions. The Contract shall inure to the benefit of and shall be binding upon the Contractor and the Owner and their respective successors and assigns.

ARTICLE XVI. SEVERABILITY; GOVERNING LAW; CHOICE OF FORUM. If any provision of the Contract shall be held invalid or unenforceable by a court of competent jurisdiction, such holding shall not invalidate or render unenforceable any other provision hereof. The Contract shall be governed by the laws of the State of California. Any action or proceeding seeking any relief under or with respect to this Agreement shall be brought solely in the Superior Court of the State of California for the County of Alameda, subject to transfer of venue under applicable State law, provided that nothing in this Agreement shall constitute a waiver of immunity to suit by Owner.

ARTICLE XVII. AMENDMENTS. The terms of the Contract shall not be waived, altered, modified, supplemented or amended in any manner whatsoever except by written agreement, which includes change orders signed by the parties and approved or ratified by the Governing Board.

ARTICLE XVIII. ASSIGNMENT OF CONTRACT. The Contractor shall not assign or transfer by operation of law or otherwise any or all of its rights, burdens,

duties or obligations without the prior written consent of the surety on the payment bond, the surety on the performance bond and the Owner.

ARTICLE XIX. WRITTEN NOTICE. Written notice shall be deemed to have been duly served if delivered in person to the individual or member of the firm or to an officer of the corporation for whom it was intended, or if delivered at or sent by registered or certified or overnight mail to the last business address known to the person who gives the notice.

CONTRACTOR:
ARNTZ BUILDERS, INC.

Signature: 

Name: Brian Proteau Date: 5/5/22

(Chairman, Pres., or Vice-Pres. President)

Signature 

Name: David Arntz Date: 5/5/22

(Secretary, Asst. Secretary, CFO, or Asst. Treasurer) Secretary/Treasurer

OAKLAND UNIFIED SCHOOL DISTRICT

 6/23/2022
Date

Gary Yee, President, Board of Education
Date
6/23/2022

 Date

**Kyla Johnson-Trammell, Superintendent,
and Secretary, Board of Education**
Date

 5/5/2022
Date

**Tadashi Nakadegwa, Deputy Chief,
Facilities Planning and Management**
Date

Approved As To Form: (Limited)

 5/5/22
Date

OUSD (Legal Counsel)

856393

CALIFORNIA CONTRACTOR'S
LICENSE NO.

3-31-2023

LICENSE EXPIRATION DATE

NOTE: Contractor must give the full business address of the Contractor and sign with Contractor's usual signature. Partnerships must furnish the full name of all partners and the Agreement must be signed in the partnership name by a general partner with authority to bind the partnership in such matters, followed by the signature and designation of the person signing. The name of the person signing shall also be typed or printed below the signature. Corporations must sign with the legal name of the corporation, followed by the name of the state of incorporation and by the signature and designation of the chairman of the board, president or any vice president, and then followed by a second signature by the secretary, assistant secretary, the chief financial officer or assistant treasurer. All persons signing must be authorized to bind the corporation in the matter. The name of each person signing shall also be typed or printed below the signature. Satisfactory evidence of the authority of the officer signing on behalf of a corporation shall be furnished.

PERFORMANCE BOND
DOCUMENT 00 61 00

Premium based on final contract price & is subject to adjustment

Bond Number: 4366507 Premium: \$106,478

KNOW ALL MEN BY THESE PRESENTS that we, Arntz Builders, Inc, as Principal, and Great American*, as Surety, are held and firmly bound unto the Oakland Unified School District, in the County of Contra Costa, State of California, hereinafter called the "Owner," in the sum of Fifteen Million ** Dollars (\$ 15,985,725.00) for the payment of which sum well and truly made, we bind ourselves, our heirs, executors, administrators, and successors, jointly and severally, to the Owner for the full performance of a certain contract with the Owner, the terms of which are incorporated herein by reference, dated May 26, 2022, for construction of *Insurance Company
** Nine Hundred Eighty Five Thousand Seven Hundred Twenty Five & 00/100

the Claremont Middle School New Multi-Purpose Building and Kitchen Project which consists of but not limited to Program a cafeteria, kitchen, stage platform, and associated support storage rooms. The project will be California High Performance School (CHPS) Designed. The building will be fully sprinklered. Site work improvements include new fencing, storm water management elements, covered pedestrian walkway, stairs, ramps, and pavement associated with the new building Renovation scope to the existing classroom building consists of removing and replacing 4 existing acoustical wall partitions with framed walls in Building A, conversion of existing restrooms in Building A, replace intrusion alarm system, removing abandoned boiler equipment in Building B, adding new utility connections for the new building. (the "Contract").

The condition of this obligation is such that, if the Principal shall well and truly perform and fulfill all the undertakings, covenants, terms, conditions, and agreements of said Contract during the original term of said Contract and any extensions thereof that may be granted by the Owner, with or without notice to the Surety, and for the period of time specified in the Contract after completion for correction of faulty or improper materials and workmanship and during the life of any guaranty or warranty required under the Contract, and shall also well and truly perform and fulfill all the undertakings, covenants, terms, conditions and agreement of any and all duly authorized modifications of said Contract that may hereafter be made, then this obligation is to be void, otherwise to remain in full force and virtue.

And the said Surety, for value received, hereby stipulates and agrees that no change, extension of time, alteration or addition to the terms of the Contract or to the Work to be performed thereunder or the specifications accompanying the same, shall in any way affect its obligation on this bond, and it does hereby waive notice of any such change, extension of time, alteration or addition to the terms of the Contract, or to the Work, or to the specifications.

No further agreement between Surety and Owner shall be required as a prerequisite to the Surety performing its obligations under this bond. In the event that the Surety elects to complete the Work of the Contract after termination of the Contract by Owner, the Surety may not hire Principal, or any of Principal's owners, employees, or subcontractors, to perform the Work without the written consent of Owner, and the Owner may grant or withhold such consent within its sole discretion.

IN WITNESS WHEREOF, the above-bounden parties have executed this instrument under their several seals this 20th day of April, 2022, hereto affixed and these presents duly signed by its undersigned representative, pursuant to authority of its governing body.

NOTWITHSTANDING the execution date above, the effective date of this bond is May 26, 2022.

(To be signed by)
(Principal and Surety,)
(and acknowledged and)
(Notarial Seal attached)

(Affix Corporate Seal)

(Individual Principal)

(Business Address)

Armtz Builders, Inc.

Brian Proteau

(Corporate Principal) Brian Proteau,
President

431 Payran Street
Petaluma, CA 94952

(Business Address)

(Affix Corporate Seal)

(Affix Corporate Seal)

Great American Insurance Company
(Corporate Surety)

1255 Treat Blvd., Suite 810
Walnut Creek, CA 94597

(Business Address)

By: *Stacy M. Clinton*

Stacy M. Clinton, Attorney-in-fact

The rate of premium on this bond is see below per thousand.

The total amount of premium charged is \$106,478.00.

The above must be filled in by Corporate Surety.

First \$500,000	\$14.40
Next \$2,000,000	\$ 8.70
Next \$2,500,000	\$ 6.90
Next \$2,500,000	\$ 6.30
Next \$8,485,725	\$ 5.76

GREAT AMERICAN INSURANCE COMPANY®

Administrative Office: 301 E 4TH STREET • CINCINNATI, OHIO 45202 • 513-369-5000 • FAX 513-723-2740

The number of persons authorized by this power of attorney is not more than SIX

No. 0 21436

POWER OF ATTORNEY

KNOW ALL MEN BY THESE PRESENTS: That the GREAT AMERICAN INSURANCE COMPANY, a corporation organized and existing under and by virtue of the laws of the State of Ohio, does hereby nominate, constitute and appoint the person or persons named below, each individually if more than one is named, its true and lawful attorney-in-fact, for it and in its name, place and stead to execute on behalf of the said Company, as surety, any and all bonds, undertakings and contracts of suretyship, or other written obligations in the nature thereof; provided that the liability of the said Company on any such bond, undertaking or contract of suretyship executed under this authority shall not exceed the limit stated below.

Name	Address	Limit of Power
K. DIXON WRIGHT	NATALIE ANN HORDER	ALL
STACY M. CLINTON	NANCY L. WALLIS	\$100,000,000
CATHERINE A. PINNEY	TAMMY CARPENTER	

This Power of Attorney revokes all previous powers issued on behalf of the attorney(s)-in-fact named above.

IN WITNESS WHEREOF the GREAT AMERICAN INSURANCE COMPANY has caused these presents to be signed and attested by its appropriate officers and its corporate seal hereunto affixed this 14TH day of MAY, 2020



My L C. B.

Assistant Secretary

GREAT AMERICAN INSURANCE COMPANY

Mark V Vicario

Divisional Senior Vice President

MARK VICARIO (877-377-2405)

STATE OF OHIO, COUNTY OF HAMILTON - ss:

On this 14TH day of MAY, 2020, before me personally appeared MARK VICARIO, to me known, being duly sworn, deposes and says that he resides in Cincinnati, Ohio, that he is a Divisional Senior Vice President of the Bond Division of Great American Insurance Company, the Company described in and which executed the above instrument; that he knows the seal of the said Company; that the seal affixed to the said instrument is such corporate seal; that it was so affixed by authority of his office under the By-Laws of said Company, and that he signed his name thereto by like authority.



SUSAN A KOHORST
Notary Public
State of Ohio
My Comm. Expires
May 18, 2025

Susan A Kohorst

This Power of Attorney is granted by authority of the following resolutions adopted by the Board of Directors of Great American Insurance Company by unanimous written consent dated June 9, 2008.

RESOLVED: That the Divisional President, the several Divisional Senior Vice Presidents, Divisional Vice Presidents and Divisional Assistant Vice Presidents, or any one of them, be and hereby is authorized, from time to time, to appoint one or more Attorneys-in-Fact to execute on behalf of the Company, as surety, any and all bonds, undertakings and contracts of suretyship, or other written obligations in the nature thereof; to prescribe their respective duties and the respective limits of their authority; and to revoke any such appointment at any time.

RESOLVED FURTHER: That the Company seal and the signature of any of the aforesaid officers and any Secretary or Assistant Secretary of the Company may be affixed by facsimile to any power of attorney or certificate of either given for the execution of any bond, undertaking, contract of suretyship, or other written obligation in the nature thereof, such signature and seal when so used being hereby adopted by the Company as the original signature of such officer and the original seal of the Company, to be valid and binding upon the Company with the same force and effect as though manually affixed.

CERTIFICATION

I, STEPHEN C. BERAHA, Assistant Secretary of Great American Insurance Company, do hereby certify that the foregoing Power of Attorney and the Resolutions of the Board of Directors of June 9, 2008 have not been revoked and are now in full force and effect.

Signed and sealed this 20th day of April, 2022



My L C. B.

Assistant Secretary

CALIFORNIA ALL-PURPOSE ACKNOWLEDGMENT

CIVIL CODE § 1189

A notary public or other officer completing this certificate verifies only the identity of the individual who signed the document to which this certificate is attached, and not the truthfulness, accuracy, or validity of that document.

State of California)
County of Sonoma)
On 4/20/22 before me, Catherine A. Pinney, Notary Public,
Date Here Insert Name and Title of the Officer
personally appeared Stacy M. Clinton
Name(s) of Signer(s)

who proved to me on the basis of satisfactory evidence to be the person(s) whose name(s) is/are subscribed to the within instrument and acknowledged to me that he/she/they executed the same in his/her/their authorized capacity(ies), and that by his/her/their signature(s) on the instrument the person(s), or the entity upon behalf of which the person(s) acted, executed the instrument.

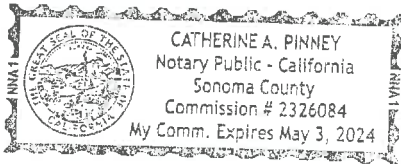

I certify under PENALTY OF PERJURY under the laws of the State of California that the foregoing paragraph is true and correct.

WITNESS my hand and official seal.

Signature [Signature]
Signature of Notary Public

Place Notary Seal Above

OPTIONAL

Though this section is optional, completing this information can deter alteration of the document or fraudulent reattachment of this form to an unintended document.

Description of Attached Document

Title or Type of Document: _____
Document Date: _____ Number of Pages: _____
Signer(s) Other Than Named Above: _____

Capacity(ies) Claimed by Signer(s)

Signer's Name: _____
 Corporate Officer — Title(s): _____
 Partner — Limited General
 Individual Attorney in Fact
 Trustee Guardian or Conservator
 Other: _____
Signer Is Representing: _____

Signer's Name: _____
 Corporate Officer — Title(s): _____
 Partner — Limited General
 Individual Attorney in Fact
 Trustee Guardian or Conservator
 Other: _____
Signer Is Representing: _____

PAYMENT BOND
DOCUMENT 00 61 01
(Labor and Material)

Bond Number: 4366507 Premium: included in performance bond

KNOW ALL MEN BY THESE PRESENTS:

That WHEREAS, the Oakland Unified School District (the "Owner" of the public works contract described below) and Armtz Builders, Inc., hereinafter designated as the "Principal," have entered into a Contract for the furnishing of all materials and labor, services and transportation, necessary, convenient, and proper to construct

the Claremont Middle School Multi-Purpose Building and Kitchen Contract, at 5750 College Avenue, Oakland, which consists of but not limited to Program a cafeteria, kitchen, stage platform, and associated support storage rooms. The project will be California High Performance School (CHPS) Designed. The building will be fully sprinklered. Site work improvements include new fencing, storm water management elements, covered pedestrian walkway, stairs, ramps, and pavement associated with the new building Renovation scope to the existing classroom building consists of removing and replacing 4 existing acoustical wall partitions with framed walls in Building A, conversion of existing restrooms in Building A, replace intrusion alarm system, removing abandoned boiler equipment in Building B, adding new utility connections for the new building./,

which said agreement dated May 26, 2022, and all of the Contract Documents are hereby referred to and made a part hereof;

and

WHEREAS, the Principal is required, before entering upon the performance of the work, to file a good and sufficient bond with the body by whom the Contract is awarded to secure the claims arising under said agreement.

NOW, THEREFORE, THESE PRESENTS WITNESSETH:

That the said Principal and the undersigned Great American Insurance Company ("Surety") are held and firmly bound unto all laborers, material men, and other persons, and bound for all amounts due, referred to in Civil Code section 9554, subdivision (b), in the sum of Fifteen Million Nine Hundred Eighty Five * Dollars (\$ 15,985,725) which sum well and truly be made, we bind ourselves, our heirs, executors, administrators, successors, or assigns, jointly and severally, by these presents.

*Thousand Seven Hundred Twenty Five & 00/100

The condition of this obligation is that if the said Principal or any of its subcontractors, or the heirs, executors, administrators, successors, or assigns of any, all, or either of them, shall fail to pay any of the persons named in Civil Code section 9100, or any of the amounts due, as specified in Civil Code section 9554, subdivision (b), that said Surety will pay the same in an amount not exceeding the amount hereinabove set forth, and also in case suit is brought upon this bond, will pay costs and reasonable attorney's fees to be awarded and fixed by the Court, and to be taxed as costs and to be included in the judgment therein rendered.

It is hereby expressly stipulated and agreed that this bond shall inure to the benefit of any and all persons, companies, and corporations entitled to file claims so as to give a right of action to them or their assigns in any suit brought upon this bond.

Should the condition of this bond be fully performed, then this obligation shall become null and void, otherwise it shall be and remain in full force and effect.

And the said Surety, for value received, thereby stipulates and agrees that no change, extension of time, alteration, or addition to the terms of said contract or the specifications accompanying the same shall in any manner affect its obligations on this bond, and it does hereby waive notice of any such change, extension, alteration, or addition.

IN WITNESS WHEREOF, this instrument has been duly executed by the Principal and Surety this 20th day of April, 2022.

NOTWITHSTANDING the execution date above, the effective date of this bond is May 26, 2022.

(To be signed by)
(Principal and Surety,)
(and acknowledged and)
(Notarial Seal attached)

Arntz Builders, Inc. _____
Principal

Brian Proteau, President

Great American Insurance Company
Surety



By: Stacy M. Clinton, Attorney-in-fact
Attorney-in-Fact

The above bond is accepted and approved this _____ day of _____.

GREAT AMERICAN INSURANCE COMPANY®

Administrative Office: 301 E 4TH STREET • CINCINNATI, OHIO 45202 • 513-369-5000 • FAX 513-723-2740

The number of persons authorized by
this power of attorney is not more than SIX

No. 0 21436

POWER OF ATTORNEY

KNOW ALL MEN BY THESE PRESENTS: That the GREAT AMERICAN INSURANCE COMPANY, a corporation organized and existing under and by virtue of the laws of the State of Ohio, does hereby nominate, constitute and appoint the person or persons named below, each individually if more than one is named, its true and lawful attorney-in-fact, for it and in its name, place and stead to execute on behalf of the said Company, as surety, any and all bonds, undertakings and contracts of suretyship, or other written obligations in the nature thereof; provided that the liability of the said Company on any such bond, undertaking or contract of suretyship executed under this authority shall not exceed the limit stated below.

Name	Address	Limit of Power
K. DIXON WRIGHT	NATALIE ANN HORDER	ALL
STACY M. CLINTON	NANCY L. WALLIS	\$100,000,000
CATHERINE A. PINNEY	TAMMY CARPENTER	

This Power of Attorney revokes all previous powers issued on behalf of the attorney(s)-in-fact named above.

IN WITNESS WHEREOF the GREAT AMERICAN INSURANCE COMPANY has caused these presents to be signed and attested by its appropriate officers and its corporate seal hereunto affixed this 14TH day of MAY, 2020

Attest

GREAT AMERICAN INSURANCE COMPANY



My L C. B.

Assistant Secretary

Mark V. Vicario

Divisional Senior Vice President

STATE OF OHIO, COUNTY OF HAMILTON - ss:

MARK VICARIO (877-377-2405)

On this 14TH day of MAY, 2020, before me personally appeared MARK VICARIO, to me known, being duly sworn, deposes and says that he resides in Cincinnati, Ohio, that he is a Divisional Senior Vice President of the Bond Division of Great American Insurance Company, the Company described in and which executed the above instrument; that he knows the seal of the said Company; that the seal affixed to the said instrument is such corporate seal; that it was so affixed by authority of his office under the By-Laws of said Company, and that he signed his name thereto by like authority.



SUSAN A KOHORST
Notary Public
State of Ohio
My Comm. Expires
May 18, 2025

Susan A Kohorst

This Power of Attorney is granted by authority of the following resolutions adopted by the Board of Directors of Great American Insurance Company by unanimous written consent dated June 9, 2008.

RESOLVED: That the Divisional President, the several Divisional Senior Vice Presidents, Divisional Vice Presidents and Divisional Assistant Vice Presidents, or any one of them, be and hereby is authorized, from time to time, to appoint one or more Attorneys-in-Fact to execute on behalf of the Company, as surety, any and all bonds, undertakings and contracts of suretyship, or other written obligations in the nature thereof; to prescribe their respective duties and the respective limits of their authority; and to revoke any such appointment at any time.

RESOLVED FURTHER: That the Company seal and the signature of any of the aforesaid officers and any Secretary or Assistant Secretary of the Company may be affixed by facsimile to any power of attorney or certificate of either given for the execution of any bond, undertaking, contract of suretyship, or other written obligation in the nature thereof, such signature and seal when so used being hereby adopted by the Company as the original signature of such officer and the original seal of the Company, to be valid and binding upon the Company with the same force and effect as though manually affixed.

CERTIFICATION

I, STEPHEN C. BERAHA, Assistant Secretary of Great American Insurance Company, do hereby certify that the foregoing Power of Attorney and the Resolutions of the Board of Directors of June 9, 2008 have not been revoked and are now in full force and effect.

Signed and sealed this 20th day of April, 2022



My L C. B.

Assistant Secretary

CALIFORNIA ALL-PURPOSE ACKNOWLEDGMENT

CIVIL CODE § 1189

A notary public or other officer completing this certificate verifies only the identity of the individual who signed the document to which this certificate is attached, and not the truthfulness, accuracy, or validity of that document.

State of California)
County of Sonoma)
On 4/20/22 before me, Catherine A. Pinney, Notary Public,
Date Here Insert Name and Title of the Officer
personally appeared Stacy M. Clinton
Name(s) of Signer(s)

who proved to me on the basis of satisfactory evidence to be the person(s) whose name(s) is/are subscribed to the within instrument and acknowledged to me that he/she/they executed the same in his/her/their authorized capacity(ies), and that by his/her/their signature(s) on the instrument the person(s), or the entity upon behalf of which the person(s) acted, executed the instrument.

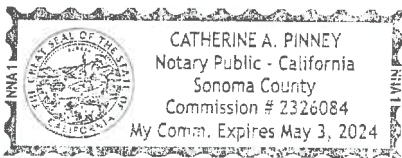

I certify under PENALTY OF PERJURY under the laws of the State of California that the foregoing paragraph is true and correct.

WITNESS my hand and official seal.

Signature [Signature]
Signature of Notary Public

Place Notary Seal Above

OPTIONAL

Though this section is optional, completing this information can deter alteration of the document or fraudulent reattachment of this form to an unintended document.

Description of Attached Document

Title or Type of Document: _____
Document Date: _____ Number of Pages: _____
Signer(s) Other Than Named Above: _____

Capacity(ies) Claimed by Signer(s)

Signer's Name: _____ Signer's Name: _____
 Corporate Officer -- Title(s): _____ Corporate Officer -- Title(s): _____
 Partner -- Limited General Partner -- Limited General
 Individual Attorney in Fact Individual Attorney in Fact
 Trustee Guardian or Conservator Trustee Guardian or Conservator
 Other: _____ Other: _____
Signer Is Representing: _____ Signer Is Representing: _____

Oakland Unified School District
Division of Facilities Planning and Management

BID OPENING TABULATION SHEET

School: Re-Bid-Claremont Middle School
 Project: Multipurpose Room & Kitchen
 Project #: 15127
 Estimate: \$13,300,000

Date: Wednesday, April 13, 2022
 Time: 2:00 P.M.
 Project Mgr: Deshonne
 Architect: S Meek Architecture

Signature of Witness to Bid

Signature of Bid Opener

Company:	Arntz Builders, Inc.	Base Bid:	\$14,685,725.00	Required Day of Bid:	
Address:	431 Payran Street	Allowance:	\$1,300,000.00	Signed Bid Form	X
City/State:	Petaluma, CA	TOTAL:	\$15,985,725.00	Addendum Acknow.	X
Phone:	707-835-2900	Alternates:		Bid Bond	X
Fax:	707-835-2993			Non-Collusion	X
				Iran Contracting Certification	X
		Time Submitted	Date Submitted	Site Visit Certification	X
		1:59 PM	4/13/2022	Contractor's Sub List	X
				Debarment Suspension & Schd Z	X
		Time Opened	Date Opened	Local Business Participation Form	X
		2:05 PM	4/13/2022	DVBE Forms	X
Company:	CWS Construction Group, Inc.	Base Bid:	\$15,650,000.00	Required Day of Bid:	
Address:	94 San Benito Way	Allowance:	\$1,300,000.00	Signed Bid Form	X
City/State:	Novato, CA	TOTAL:	\$16,950,000.00	Addendum Acknow.	X
Phone:		Alternates:		Bid Bond	X
Fax:				Non-Collusion	X
				Iran Contracting Certification	X
		Time Submitted	Date Submitted	Site Visit Certification	X
		1:59 PM	4/13/2022	Contractor's Sub List	X
				Debarment Suspension & Schd Z	X
		Time Opened	Date Opened	Local Business Participation Form	X
		2:05 PM	4/13/2022	DVBE Forms	X
Company:	Thompson/Focon JV	Base Bid:	\$15,889,000.00	Required Day of Bid:	
Address:	5400 Hanna Ranch Rd	Allowance:	\$1,300,000.00	Signed Bid Form	X
City/State:	Novato, CA	TOTAL:	\$17,189,000.00	Addendum Acknow.	X
Phone:	415-456-8972	Alternates:		Bid Bond	X
Fax:				Non-Collusion	X
				Iran Contracting Certification	X
		Time Submitted	Date Submitted	Site Visit Certification	X
		1:59 PM	4/13/2022	Contractor's Sub List	X
				Debarment Suspension & Schd Z	X
		Time Opened	Date Opened	Local Business Participation Form	X
		2:05 PM	4/13/2022	DVBE Forms	X
Company:	Wickman Development & Construction	Base Bid:	\$15,997,000.00	Required Day of Bid:	
Address:	5616 Mission St	Allowance:	\$1,300,000.00	Signed Bid Form	X
City/State:	San Francisco, CA	TOTAL:	\$17,776,910.00	Addendum Acknow.	X
Phone:	415-239-4500	Alternates:		Bid Bond	X
Fax:				Non-Collusion	X
				Iran Contracting Certification	X
		Time Submitted	Date Submitted	Site Visit Certification	X
		1:58 PM	4/13/2022	Contractor's Sub List	X
				Debarment Suspension & Schd Z	X
		Time Opened	Date Opened	Local Business Participation Form	X
		2:05 PM	4/13/2022	DVBE Forms	X



LBU Program Consultants to OUSD

MEMORANDUM

Date: April 14th, 2022

To: Juanita Hunter

From: Philip Lang, LBU Consultant

Subject: LBU Review

Project # 15127

Notice to Bidders – Claremont Middle School New Multi-Purpose Room & Kitchen

Arntz Builders

SUMMARY

The LBU Compliance Team has conducted a review of the Local Business Participation Worksheet for the Claremont Middle School New Multi-Purpose Room & Kitchen project submitted by Arntz Builders, Inc..

- Arntz Builders, Inc. achieved 65.5% LBU (10.5% LBE and 55%% SLBE/SLRBE).

RECOMMENDATION:

Based on the LBU Participation Worksheet, the Compliance Team finds Arntz Builders to be responsive and eligible for contract award.

Cc: Kenya Chatman

Tadashi Nakadegawa



LBU Program Consultants to OUSD

MEMORANDUM

Date: April 15th, 2022

To: Juanita Hunter

From: Philip Lang, LBU Consultant

Subject: LBU Review

Project # 15127

Notice to Bidders – Claremont Middle School New Multi-Purpose Room & Kitchen

CWS Construction

SUMMARY

The LBU Compliance Team has conducted a review of the Local Business Participation Worksheet for the Claremont Middle School New Multi-Purpose Room & Kitchen project submitted by Wickman Development & Construction.

- CWS Construction did not achieve 50% LBU (26.1%% LBE and 21.8% SLBE/SLRBE).

RECOMMENDATION:

Based on the LBU Participation Worksheet, the Compliance Team finds CWS Construction to be nonresponsive and ineligible for contract award.

Cc: Kenya Chatman

Tadashi Nakadegawa



LBU Program Consultants to OUSD

MEMORANDUM

Date: April 15th, 2022

To: Juanita Hunter

From: Philip Lang, LBU Consultant

Subject: LBU Review

Project # 15127

Notice to Bidders – Claremont Middle School New Multi-Purpose Room & Kitchen
Thompson/Focon JV

SUMMARY

After careful review of the Joint Venture Agreement submitted by Thompson Builders, Inc. and Focon, Inc., it is determined that all documented components have been met in accordance with The Oakland Unified School District's Local Business Policy. Thompson/Focon JV is therefore eligible to bid OUSD projects and will receive credit in accordance with the Local Business Utilization percentage identified in the agreement.

Please note, per Administrative Regulation 7115:

- a. The joint venture agreement must remain in effect of the life of the project,
- b. Any changes to the agreement must also receive prior approval from the District's Facilities Director or designee
- c. Each SLBE/SLRBE joint venture must provide upon request, cancelled checks and any other financial records to the District.

The LBU Compliance Team has also conducted a review of the Local Business Participation Worksheet for the Claremont Middle School New Multi-Purpose Room & Kitchen project submitted by Thompson Builders, Inc. and Focon, Inc. as Joint Venture.

- Thompson/Focon JV achieved 53.4% LBU (1.7% LBE and 51.7%% SLBE/SLRBE).

RECOMMENDATION:

Based on the LBU Participation Worksheet, the Compliance Team finds Thompson/Focon JV to be responsive and eligible for contract award.

Cc: Kenya Chatman

Tadashi Nakadegawa



LBU Program Consultants to OUSD

MEMORANDUM

Date: April 14th, 2022

To: Juanita Hunter

From: Philip Lang, LBU Consultant

Subject: LBU Review

Project # 15127

Notice to Bidders – Claremont Middle School New Multi-Purpose Room & Kitchen

Wickman Construction & Development

SUMMARY

The LBU Compliance Team has conducted a review of the Local Business Participation Worksheet for the Claremont Middle School New Multi-Purpose Room & Kitchen project submitted by Wickman Development & Construction.

- Wickman Development & Construction did not achieve 50% LBU (27.4%% LBE and 21.3% SLBE/SLRBE).

RECOMMENDATION:

Based on the LBU Participation Worksheet, the Compliance Team finds Wickman Development & Construction to be nonresponsive and ineligible for contract award.

Cc: Kenya Chatman

Tadashi Nakadegawa

BID FORM
DOCUMENT 00 31 01

OAKLAND UNIFIED SCHOOL DISTRICT
Facilities Planning & Management
955 High Street,
Oakland, CA. 94601

Dear Board Members:

The undersigned, doing business under the firm name of Arntz Builders, Inc. ("Bidder"), hereby proposes and agrees to enter into a contract, with the Oakland Unified School District ("Owner"), to furnish any and all labor, materials, applicable taxes, equipment and services for the completion of Work as described hereinafter and in the Contract Documents as **Claremont Middle School New Multi-Purpose Building and Kitchen Project, 5750 College Ave, Oakland, CA 94619 (the "Contract"), Project No. 15127**

The Contract Documents were prepared by S Meek Architecture, 3040 24th Street, San Francisco, CA., 94110; (415) 543-5505

The undersigned proposes to furnish such labor, materials, applicable taxes, equipment and services for the amount of:

Fourteen million nine hundred twelve	Dollars	\$	14,085,725
<u>BP fourteen million six hundred eighty-five</u>	<u>Dollars</u>	<u>\$</u>	<u>14,685,725</u>
<u>Base Bid Amount</u>			
<u>One Million Three Hundred Thousand</u>	<u>Dollars</u>		<u>\$1,300,000.00</u>
<u>Contingency Allowance</u>			
Sixteen million two hundred twelve	Dollars	\$	16,212,000
<u>BP fifteen million nine hundred eighty-five</u>	<u>Dollars</u>	<u>\$</u>	<u>15,985,725</u>
<u>Total Bid Amount</u>			

seven hundred twenty five thousand

seven hundred twenty five

Bidder acknowledges and agrees that the Total Bid accounts for any and all Allowances and contingencies in the Contract Document.

This amount includes all allowances identified in the Agreement form (see Article IV), including but not limited to a contingency allowance of: **One Million Three Hundred Thousand dollars (\$1,300,000.00)**.

Miscellaneous:

The low bid shall be determined as described in the Notice to Bidders.

The undersigned certifies to the best of its knowledge and belief that it and its officials are not presently debarred, suspended, proposed for debarment, declared ineligible, or voluntarily excluded from covered transactions by any Federal department or agency according to Federal Acquisition Regulation Subpart 9.4, and by signing this contract certifies that this vendor does not appear on the Excluded Parties List.
<https://www.sam.gov/portal/public/SAM>

If written notice of the Award of Contract is mailed, faxed, or delivered to the undersigned at any time before this bid is withdrawn, the undersigned shall, within ten (10) days after the date of such mailing, faxing, or delivering of such notice, execute and deliver an agreement in the form of agreement present in these Contract Documents and give Performance and Payment Bonds in accordance with the specifications and bid as accepted.

The undersigned declares that Bidder has read and understands the Contract Documents, including but not limited to the Notice to Bidders, the Instructions to Bidders, the Agreement, the General Conditions, the Drawings, the Specifications, and any Special Conditions.

The undersigned hereby designates as the office to which such Notice of Award of Contract may be mailed, faxed, or delivered:
Arntz Builders, Inc. 431 Payran Street, Petaluma, CA 94952

Our Public Liability and Property Damage Insurance is placed with:
Zurich American Insurance Company

Our Workers' Compensation Insurance is placed with:
Travelers Property Casualty Company of America

Circular letters, bulletins, addenda, etc., bound with the specifications or issued during the time of bidding are included in the bid, and, in Completing the Contract, they are to become a part thereof.

The receipt of the following addenda to the specifications is acknowledged:

Addendum No. <u>1</u>	Date <u>2/22/22</u>	Addendum No. <u>6</u>	Date <u>3/11/22</u>
Addendum No. <u>2</u>	Date <u>2/7/22</u>	Addendum No. <u>7</u>	Date <u>4/4/22</u>
Addendum No. <u>3</u>	Date <u>2/18/22</u>	Addendum No. <u>8</u>	Date <u>4/8/22</u>
Addendum No. <u>4</u>	Date <u>2/23/22</u>	Addendum No. <u>9</u>	Date <u>4/11/22</u>
Addendum No. <u>5</u>	Date <u>3/11/22</u>		

This bid may be withdrawn at any time prior to the scheduled time for the opening of bids or any authorized postponement thereof.

A bidder shall not submit a bid unless the bidder's California contractor's license number appears clearly on the bid, the license expiration date and class are stated, and the bid contains a statement that the representations made therein are made under penalty of perjury. Any bid submitted by a contractor who is not licensed pursuant to Business and Professions Code section 7028.15 shall be considered nonresponsive and shall be rejected. Any bid not containing the above information may be considered nonresponsive and may be rejected.

Proof of Bidder's registration per Labor Code §1725.5 must be submitted with this bid form.

NOTE: Each bid must give the full business address of the bidder and be signed by bidder with bidder's usual signature. Bids by partnerships must furnish the full name of all partners and must be signed in the partnership name by a general partner with authority to bind the partnership in such matters, followed by the signature and designation of the person signing. The name of the person signing shall also be typed or printed below the signature. Bids by corporations must be signed with the legal name of the corporation, followed by the name of the state of incorporation and by the signature and designation of the chairman of the board, president or any vice president, and then followed by a second signature by the secretary, assistant secretary, the chief financial officer or assistant treasurer. All persons signing must be authorized to bind the corporation in the matter. The name of each person signing shall also be typed or printed below the signature. Satisfactory evidence of the authority of the officers signing on behalf of a corporation shall be furnished with the bid.

The undersigned declares under penalty of perjury under the laws of the State of California that the representations made in this bid are true and correct.

Print or Type Name: Brian Proteau
Signature : 
Title: President
Name of Company as Licensed in California: Arntz Builders, Inc.
Business Address: 431 Payran Street, Petaluma, CA 94952
Telephone Number: 707-835-2900
California Contractor License No.: 856393
Class and Expiration Date: A, B; Exp 3/31/23
Public Works Contractor Registration No.: 1000003147
State of Incorporation, if Applicable: California

David Arntz, Secretary/Treasurer

LOCAL BUSINESS PARTICIPATION WORKSHEET

PRIME: Arntz Builders, Inc.
Project: Claremont MS New Multi-Purpose and Kitchen
Project #: 15127
Estimate: \$13,000,000

Bid Opening Date: April 13, 2022
Time: 2pm
Project Mgr: Deshonnie Hall
Architect: S Meek Architecture

Base Bid Dollar Amount	\$	Note: Please complete dollar amounts for sub/prime work; local business percentages; base bid			
14,485,725 BP 14,485,725	Total Dollar Amount of Work	LBE %	SLB%	SLBR%	City of Oakland Certification No.
PRIME Company: Arntz Builders, Inc. Address: 431 Payran Street City/State: Petaluma, CA 94952 Phone: 707-835-2900	\$				
Company: Focon Inc. Address: 1305 Franklin Street #304 City/State: Oakland, CA Phone: 510-465-6319	\$ 2,028,160		14%		5077
Company: Light Frame Construcion Address: 22 Moss Ave Unit 108 City/State: Oakland, CA Phone: 510-715-0025	\$ 2,484,527		17%		7311
Company: Tulum Systems Address: 3101 Hyde St. City/State: Oakland, CA Phone: 510-270-0000 510-355-2159	\$ 1,998,980 BP 1,998,980		13%		7831
Company: BP Address: BP City/State: BP Phone: BP	\$				BP
TOTAL PARTICIPATION	\$0.00	0.0%	0.0%	0.0%	0.0%

APPROVAL- LBU Compliance Officer

LOCAL BUSINESS PARTICIPATION WORKSHEET (TRUCKING) FOR BIDS ONLY

PRIME: Arntz Builders, Inc.

Bid Opening Date: April 13, 2022

Note: Local Business Participation documentation must be included with bid form at the time of bid opening.

LOCAL BUSINESS PARTICIPATION WORKSHEET

PRIME: Arntz Builders, Inc.
Project: Claremont MS New Multi-Purpose and Kitchen
Project #: 15127
Estimate: \$13,000,000

Bid Opening Da: April 13, 2022
Time: 2pm
Project Mgr: Deshonnie Hall
Architect: S Meek Architecture

Base Bid Dollar Amount	\$	Note: Please complete dollar amounts for sub/prime work; local business percentages; base bid			
	Total Dollar Amount of Work	LBE %	SLB%	SLBR%	City of Oakland Certification No.
PRIME Company:					
Address:	\$				
City/State:					
Phone:					
Company: XXXXXXXXXX					
Address: XXXXXXXXXX BP	\$				BP
City/State: XXXXXXXXXX					
Phone: XXXXXXXXXX					
Company: XXXXXXXXXX					
Address: XXXXXXXXXX BP	\$				BP
City/State: XXXXXXXXXX					
Phone: XXXXXXXXXX					
Company: Hartley Const					
Address: 1626 Milk Jr. Way	\$ XXXXXXXXXX BP		7.5%		7251
City/State: Oakland, CA	1,124,208		BP		
Phone: 510-238-8592					
Company: Brite Painting					
Address: 739 Worfield Ave	\$ 85,678		1%		5395
City/State: Oakland, CA					
Phone: 510-276-5000					
TOTAL PARTICIPATION	\$0.00	0.0%	0.0%	0.0%	0.0%

APPROVAL- LBU Compliance Officer

LOCAL BUSINESS PARTICIPATION WORKSHEET (TRUCKING) FOR BIDS ONLY

PRIME: Arntz Builders, Inc.

Bid Opening Da: April 13, 2022

Note: Local Business Participation documentation must be included with bid form at the time of bid opening.

LOCAL BUSINESS PARTICIPATION WORKSHEET

PRIME: Arntz Builders, Inc.
Project: Claremont MS New Multi-Purpose and Kitchen
Project #: 15127
Estimate: \$13,000,000

Bid Opening Date: April 13, 2022
Time: 2pm
Project Mgr: Deshonne Hall
Architect: S Meek Architecture

Base Bid Dollar Amount	\$	Note: Please complete dollar amounts for sub/prime work; local business percentages; base bid			
	Total Dollar Amount of Work	LBE %	SLB%	SLBR%	City of Oakland Certification No.
PRIME Company:					
Address:	\$				
City/State:					
Phone:					
Company:					
Address:	\$				BP
City/State:					
Phone:					
Company:					
Address:	\$				BP
City/State:					
Phone:					
Company:					
Address:	\$				BP
City/State:					
Phone:					
Company: AM6					
Address: 3438 Helen St	\$ 45,000		.05%		5331
City/State: Oakland, CA					
Phone: 510-454-8441					
TOTAL PARTICIPATION	\$0.00	0.0%	0.0%	0.0%	0.0%

APPROVAL- LBU Compliance Officer

LOCAL BUSINESS PARTICIPATION WORKSHEET (TRUCKING) FOR BIDS ONLY

PRIME: Arntz Builders, Inc.

Bid Opening Date: April 13, 2022

Note: Local Business Participation documentation must be included with bid form at the time of bid opening.

LOCAL BUSINESS PARTICIPATION WORKSHEET

PRIME: Arntz Builders, Inc.
Project: Claremont MS New Multi-Purpose and Kitchen
Project #: 15127
Estimate: \$13,000,000

Bid Opening Date: April 13, 2022
Time: 2pm
Project Mgr: Deshonnie Hall
Architect: S Meek Architecture

Base Bid Dollar Amount	\$	Note: Please complete dollar amounts for sub/prime work; local business percentages; base bid			
	Total Dollar Amount of Work	LBE %	SLB%	SLBR%	City of Oakland Certification No.
PRIME Company:					
Address:	\$				
City/State:					
Phone:					
Company: Lopez Const	\$ 300,000		2%		2017002503
Address: 240 Sextus Rd.					
City/State: Oakland, CA					
Phone: 510-415-3654					
Company: RMT	\$ 191,315	1.5%			6696
Address: 421 Pendleton way					
City/State: OAKLAND, CA					
Phone: 510-569-3268					
Company: BP	\$				
Address: BP					
City/State: BP					
Phone: BP					
Company: AVR Glass	\$ 320,000		2%		12-00073
Address: 9134 Popwell Drive					
City/State: OAKLAND, CA					
Phone: 810-430-2977					
TOTAL PARTICIPATION	\$0.00	0.0%	0.0%	0.0%	0.0%

APPROVAL- LBU Compliance Officer

LOCAL BUSINESS PARTICIPATION WORKSHEET (TRUCKING) FOR BIDS ONLY

PRIME: Arntz Builders, Inc.

Bid Opening Date: April 13, 2022

Note: Local Business Participation documentation must be included with bid form at the time of bid opening.

Project: **Claremont MS New Multi-Purpose and Kitchen**
Project #:15127
Estimate: \$13,000,000

Time: 2pm
Project Mgr: Deshonne Hall
Architect: S Meek Architecture

Trucking Base Bid	Total Dollar Amount of Work	LBE %	SLB%	SLBR%	City of Oakland Certification No.
TRUCKING AD TRUCKING Address: 1941 Jackson St. City/State: Oakland, CA Phone: 408-710-5173	\$ 15,000				8973-21
Company: Broadway MPM Address: 873 81st Ave City/State: Oakland, CA Phone: 510-746-4000	\$ 1,101,067	7%			6366
Company: Address: City/State: Phone:	\$				
Company: Address: City/State: Phone:	\$				
TOTAL PARTICIPATION	\$0.00	0.0%	0.0%	0.0%	0.0%

Note: Please complete dollar amounts for sub and prime work; local business percentages; base bid

APPROVAL- LBU Compliance Officer

Note: Local Business Participation documentation must be included with bid form at the time of bid opening.



EVIDENCE OF PROPERTY INSURANCE

Date (MM/DD/YYYY)
4/22/2022

THIS EVIDENCE OF PROPERTY INSURANCE IS ISSUED AS A MATTER OF INFORMATION ONLY AND CONFERS NO RIGHTS UPON THE ADDITIONAL INTEREST NAMED BELOW. THIS EVIDENCE DOES NOT AFFIRMATIVELY OR NEGATIVELY AMEND, EXTEND OR ALTER THE COVERAGE AFFORDED BY THE POLICIES BELOW. THIS EVIDENCE OF INSURANCE DOES NOT CONSTITUTE A CONTRACT BETWEEN THE ISSUING INSURER(S), AUTHORIZED REPRESENTATIVE OR PRODUCER, AND THE ADDITIONAL INTEREST.

PRODUCER NAME, CONTACT, PERSON AND ADDRESS		Phone (A/C, No, Ext): 707-781-3400	COMPANY NAME AND ADDRESS		NAIC NO: 27960
Heffernan Insurance Brokers 101 Second Street, #120 Petaluma, CA 94952 CA License# 0564249			Illinois Union Insurance Company		
FAX (A/C, No): 213-623-1388		E-MAIL ADDRESS:			
CODE:		SUB CODE:		POLICY TYPE: BUILDERS RISK	
AGENCY CUSTOMER ID#:		LOAN NUMBER		POLICY NUMBER I1119462A001	
NAMED INSURED AND ADDRESS Arntz Builders, Inc. 431 Payran Petaluma, CA 94952		EFFECTIVE DATE 12/07/2021	EXPIRATION DATE 12/01/2022	UNTIL <input type="checkbox"/> CONTINUED <input type="checkbox"/> TERMINATED IF CHECKED	

PROPERTY INFORMATION

LOCATION/DESCRIPTION

Project# 15127 - Claremont Middle School Multi-Purpose and Kitchen Project

THE POLICIES OF INSURANCE LISTED BELOW HAVE BEEN ISSUED TO THE INSURED NAMED ABOVE FOR THE POLICY PERIOD INDICATED. NOT WITHSTANDING ANY REQUIREMENT, TERM OR CONDITION OF ANY CONTRACT OR OTHER DOCUMENT WITH RESPECT TO WHICH THIS EVIDENCE OF PROPERTY INSURANCE MAY BE ISSUED OR MAY PERTAIN, THE INSURANCE AFFORDED BY THE POLICIES DESCRIBED HEREIN IS SUBJECT TO ALL OF THE TERMS, EXCLUSIONS AND CONDITIONS OF SUCH POLICIES. LIMITS SHOWN MAY HAVE BEEN REDUCED BY PAID CLAIMS.

COVERAGE INFORMATION

COVERAGE/PERILS/FORMS	AMOUNT OF INSURANCE	DEDUCTIBLE
Builders Risk Limit	\$15,985,725	\$10,000, Except \$100,000 for Water Damage
Earthquake	\$15,985,725	5%, subject to a minimum \$100,000
Flood	\$15,985,725	2%, subject to a minimum \$100,000

REMARKS (Including Special Conditions)

--

CANCELLATION

SHOULD ANY OF THE ABOVE DESCRIBED POLICIES BE CANCELLED BEFORE THE EXPIRATION DATE THEREOF, NOTICE WILL BE DELIVERED IN ACCORDANCE WITH THE POLICY PROVISIONS.

ADDITIONAL INTEREST

NAME AND ADDRESS Oakland Unified School District 955 High Street Oakland, CA 94601	<input type="checkbox"/>	MORTGAGEE	<input type="checkbox"/>	ADDITIONAL INSURED
	<input type="checkbox"/>	LOSS PAYEE	<input type="checkbox"/>	
	LOAN #			
AUTHORIZED REPRESENTATIVE 				



CERTIFICATE OF LIABILITY INSURANCE

DATE (MM/DD/YYYY)

4/22/2022

THIS CERTIFICATE IS ISSUED AS A MATTER OF INFORMATION ONLY AND CONFERS NO RIGHTS UPON THE CERTIFICATE HOLDER. THIS CERTIFICATE DOES NOT AFFIRMATIVELY OR NEGATIVELY AMEND, EXTEND OR ALTER THE COVERAGE AFFORDED BY THE POLICIES BELOW. THIS CERTIFICATE OF INSURANCE DOES NOT CONSTITUTE A CONTRACT BETWEEN THE ISSUING INSURER(S), AUTHORIZED REPRESENTATIVE OR PRODUCER, AND THE CERTIFICATE HOLDER.

IMPORTANT: If the certificate holder is an ADDITIONAL INSURED, the policy(ies) must have ADDITIONAL INSURED provisions or be endorsed. If SUBROGATION IS WAIVED, subject to the terms and conditions of the policy, certain policies may require an endorsement. A statement on this certificate does not confer rights to the certificate holder in lieu of such endorsement(s).

PRODUCER (PT) Heffernan Insurance Brokers 101 Second Street, Suite 120 Petaluma CA 94952 License#: 0564249 ARNTBUI-02	CONTACT NAME: PHONE (A/C, No, Ext): 707-781-3400 FAX (A/C, No): 707-781-0800 E-MAIL ADDRESS:													
	<table border="1"> <thead> <tr> <th>INSURER(S) AFFORDING COVERAGE</th> <th>NAIC #</th> </tr> </thead> <tbody> <tr> <td>INSURER A : Zurich American Insurance Company</td> <td>16535</td> </tr> <tr> <td>INSURER B : Travelers Property Casualty Company of America</td> <td>25674</td> </tr> <tr> <td>INSURER C : Westchester Fire Insurance Company</td> <td>10030</td> </tr> <tr> <td>INSURER D : Philadelphia Indemnity Insurance Company</td> <td>18058</td> </tr> <tr> <td>INSURER E : Palomar Excess and Surplus Insurance Company</td> <td>16754</td> </tr> <tr> <td>INSURER F :</td> <td></td> </tr> </tbody> </table>	INSURER(S) AFFORDING COVERAGE	NAIC #	INSURER A : Zurich American Insurance Company	16535	INSURER B : Travelers Property Casualty Company of America	25674	INSURER C : Westchester Fire Insurance Company	10030	INSURER D : Philadelphia Indemnity Insurance Company	18058	INSURER E : Palomar Excess and Surplus Insurance Company	16754	INSURER F :
INSURER(S) AFFORDING COVERAGE	NAIC #													
INSURER A : Zurich American Insurance Company	16535													
INSURER B : Travelers Property Casualty Company of America	25674													
INSURER C : Westchester Fire Insurance Company	10030													
INSURER D : Philadelphia Indemnity Insurance Company	18058													
INSURER E : Palomar Excess and Surplus Insurance Company	16754													
INSURER F :														
INSURED Arntz Builders, Inc 431 Payran St. Petaluma CA 94952														

COVERAGES **CERTIFICATE NUMBER:** 1698240607 **REVISION NUMBER:**

THIS IS TO CERTIFY THAT THE POLICIES OF INSURANCE LISTED BELOW HAVE BEEN ISSUED TO THE INSURED NAMED ABOVE FOR THE POLICY PERIOD INDICATED. NOTWITHSTANDING ANY REQUIREMENT, TERM OR CONDITION OF ANY CONTRACT OR OTHER DOCUMENT WITH RESPECT TO WHICH THIS CERTIFICATE MAY BE ISSUED OR MAY PERTAIN, THE INSURANCE AFFORDED BY THE POLICIES DESCRIBED HEREIN IS SUBJECT TO ALL THE TERMS, EXCLUSIONS AND CONDITIONS OF SUCH POLICIES. LIMITS SHOWN MAY HAVE BEEN REDUCED BY PAID CLAIMS.

INSR LTR	TYPE OF INSURANCE	ADDL INSD	SUBR WVD	POLICY NUMBER	POLICY EFF (MM/DD/YYYY)	POLICY EXP (MM/DD/YYYY)	LIMITS
A	<input checked="" type="checkbox"/> COMMERCIAL GENERAL LIABILITY <input type="checkbox"/> CLAIMS-MADE <input checked="" type="checkbox"/> OCCUR <input checked="" type="checkbox"/> \$5,000 Ded GEN'L AGGREGATE LIMIT APPLIES PER: <input type="checkbox"/> POLICY <input checked="" type="checkbox"/> PRO-JECT <input type="checkbox"/> LOC <input type="checkbox"/> OTHER:	Y		GLA065510001	12/1/2021	12/1/2022	EACH OCCURRENCE \$2,000,000 DAMAGE TO RENTED PREMISES (Ea occurrence) \$300,000 MED EXP (Any one person) \$10,000 PERSONAL & ADV INJURY \$2,000,000 GENERAL AGGREGATE \$4,000,000 PRODUCTS - COMP/OP AGG \$4,000,000 \$
A	<input checked="" type="checkbox"/> AUTOMOBILE LIABILITY <input checked="" type="checkbox"/> ANY AUTO <input type="checkbox"/> OWNED AUTOS ONLY <input type="checkbox"/> SCHEDULED AUTOS <input type="checkbox"/> HIRED AUTOS ONLY <input type="checkbox"/> NON-OWNED AUTOS ONLY	Y		GLA065510001	12/1/2021	12/1/2022	COMBINED SINGLE LIMIT (Ea accident) \$2,000,000 BODILY INJURY (Per person) \$ BODILY INJURY (Per accident) \$ PROPERTY DAMAGE (Per accident) \$ \$
C	<input type="checkbox"/> UMBRELLA LIAB <input checked="" type="checkbox"/> OCCUR <input checked="" type="checkbox"/> EXCESS LIAB <input type="checkbox"/> CLAIMS-MADE <input type="checkbox"/> DED <input checked="" type="checkbox"/> RETENTION \$ 0			G71466061004	12/1/2021	12/1/2022	EACH OCCURRENCE \$10,000,000 AGGREGATE \$10,000,000 1st Layer \$
B	WORKERS COMPENSATION AND EMPLOYERS' LIABILITY ANY PROPRIETOR/PARTNER/EXECUTIVE OFFICER/MEMBER EXCLUDED? (Mandatory in NH) If yes, describe under DESCRIPTION OF OPERATIONS below	Y/N	N/A	UB9R8703282126G	10/1/2021	10/1/2022	<input checked="" type="checkbox"/> PER STATUTE <input type="checkbox"/> OTHER E.L. EACH ACCIDENT \$1,000,000 E.L. DISEASE - EA EMPLOYEE \$1,000,000 E.L. DISEASE - POLICY LIMIT \$1,000,000
D	2nd Layer Excess			PHUB794526	12/1/2021	12/1/2022	Per Occ/Aggregate 10,000,000
E	3rd Layer Excess			PESXS010100	12/1/2021	12/1/2022	Per Occ/Aggregate 5,000,000

DESCRIPTION OF OPERATIONS / LOCATIONS / VEHICLES (ACORD 101, Additional Remarks Schedule, may be attached if more space is required)
 Re: Project# 15127 - Claremont Middle School Multi-Purpose and Kitchen Project. Oakland Unified School District and Architect are included as Additional Insured on the General Liability (Includes Completed Ops) and also on the Auto Liability policies per the attached, if required.

CERTIFICATE HOLDER**CANCELLATION**

Oakland Unified School District
 955 High Street
 Oakland CA 94601

SHOULD ANY OF THE ABOVE DESCRIBED POLICIES BE CANCELLED BEFORE THE EXPIRATION DATE THEREOF, NOTICE WILL BE DELIVERED IN ACCORDANCE WITH THE POLICY PROVISIONS.

AUTHORIZED REPRESENTATIVE

© 1988-2015 ACORD CORPORATION. All rights reserved.

Limited Operations Coverage – Work Excluded Under A Consolidated (Wrap-Up) Insurance Program



Policy No.	Eff. Date of Pol.	Exp. Date of Pol.	Eff. Date of End.	Producer No.	Add'l. Prem	Return Prem.
GLA 0655100-01	12/01/2021	12-01-2022		31400000	INCL	

THIS ENDORSEMENT CHANGES THE POLICY. PLEASE READ IT CAREFULLY.

Named Insured: ARNTZ BUILDERS, INC.

Address (including ZIP Code): 431 Payran, Petaluma, CA 94952

This endorsement modifies insurance provided under the:

Commercial General Liability Coverage Part

SCHEDULE

Description and Location of Operation(s):

ANY LOCATION WHERE THE INSURED HAS, OR HAD, OPERATIONS INSURED BY A CONSOLIDATED (WRAP-UP) INSURANCE PROGRAM.

(If no entry appears above, information required to complete this endorsement will be shown in the Declarations as applicable to this endorsement.)

A. The following exclusion is added to paragraph 2., Exclusions of Coverage A – Bodily Injury and Property Damage Liability (Section I – Coverages):

This insurance does not apply to "bodily injury" or "property damage" arising out of either your ongoing operations or operations included within the "products-completed operations hazard" at the location described in the **SCHEDULE** of this endorsement, as a consolidated (wrap-up) insurance program has been provided by the prime contractor/project manager or owner of the construction project in which you are involved.

This exclusion applies whether or not the consolidated (wrap-up) insurance program:

1. Provides coverage identical to that provided by this Coverage Part;
2. Has limits adequate to cover all claims; or
3. Remains in effect.

B. The exclusion in A. above shall not apply to your ongoing operations at the location shown in the **SCHEDULE for your service, maintenance, correction, repair or replacement of the original work performed and insured under the consolidated wrap-up insurance program.**

However, this extension of coverage does not apply to damages because of "bodily injury" or "property damage" due to any service, maintenance, correction, repair or replacement work:

1. as respects the "products-completed operations hazard"; or
2. for which coverage is afforded under the consolidated (wrap-up) insurance program.

C. For the application of the coverage provided by this endorsement in paragraph B. above, **SECTION IV – COMMERCIAL GENERAL LIABILITY CONDITIONS** paragraph 4 **Other Insurance** is replaced by the following:

This insurance is excess over any other insurance, whether primary, excess, contingent or on any other basis. If any other insurance responds or can respond to this loss, we shall have the right but not the duty to defend any "suit".

When this insurance is excess over other insurance, we will pay only our share of the amount of the loss, if any, that exceeds the sum of:

1. The total amount that all such other insurance would pay for the loss in the absence of this insurance; and
2. The total of all deductible and self-insured amounts under all that other insurance.

We will share the remaining loss, if any, with any other insurance that may apply and that was not bought specifically to apply in excess of the Limits of Insurance shown in the Declarations of this Coverage Part.

Countersigned

Authorized Representative

Coverage Extension Endorsement



Policy No.	Eff. Date of Pol.	Exp. Date of Pol.	Eff. Date of End.	Producer No.	Add'l. Prem	Return Prem.
GLA 0655100-01	12/01/2021	12/01/2022		31400000	INCL	

THIS ENDORSEMENT CHANGES THE POLICY. PLEASE READ IT CAREFULLY.

This endorsement modifies insurance provided under the:

**Business Auto Coverage Form
Motor Carrier Coverage Form**

A. Amended Who Is An Insured

1. The following is added to the **Who Is An Insured** Provision in **Section II – Covered Autos Liability Coverage**:

The following are also "insureds":

- a. Any "employee" of yours is an "insured" while using a covered "auto" you don't own, hire or borrow for acts performed within the scope of employment by you. Any "employee" of yours is also an "insured" while operating an "auto" hired or rented under a contract or agreement in an "employee's" name, with your permission, while performing duties related to the conduct of your business.
- b. Anyone volunteering services to you is an "insured" while using a covered "auto" you don't own, hire or borrow to transport your clients or other persons in activities necessary to your business.
- c. Anyone else who furnishes an "auto" referenced in Paragraphs **A.1.a.** and **A.1.b.** in this endorsement.
- d. Where and to the extent permitted by law, any person(s) or organization(s) where required by written contract or written agreement with you executed prior to any "accident", including those person(s) or organization(s) directing your work pursuant to such written contract or written agreement with you, provided the "accident" arises out of operations governed by such contract or agreement and only up to the limits required in the written contract or written agreement, or the Limits of Insurance shown in the Declarations, whichever is less.

2. The following is added to the **Other Insurance** Condition in the Business Auto Coverage Form and the **Other Insurance – Primary and Excess Insurance Provisions Condition** in the Motor Carrier Coverage Form:

Coverage for any person(s) or organization(s), where required by written contract or written agreement with you executed prior to any "accident", will apply on a primary and non-contributory basis and any insurance maintained by the additional "insured" will apply on an excess basis. However, in no event will this coverage extend beyond the terms and conditions of the Coverage Form.

B. Amendment – Supplementary Payments

Paragraphs **a.(2)** and **a.(4)** of the **Coverage Extensions** Provision in **Section II – Covered Autos Liability Coverage** are replaced by the following:

- (2) Up to \$5,000 for the cost of bail bonds (including bonds for related traffic law violations) required because of an "accident" we cover. We do not have to furnish these bonds.
- (4) All reasonable expenses incurred by the "insured" at our request, including actual loss of earnings up to \$500 a day because of time off from work.

C. Fellow Employee Coverage

The **Fellow Employee** Exclusion contained in **Section II – Covered Autos Liability Coverage** does not apply.

D. Driver Safety Program Liability and Physical Damage Coverage

1. The following is added to the **Racing** Exclusion in **Section II – Covered Autos Liability Coverage**:

This exclusion does not apply to covered "autos" participating in a driver safety program event, such as, but not limited to, auto or truck rodeos and other auto or truck agility demonstrations.

2. The following is added to Paragraph **2.** in the **Exclusions** of **Section III – Physical Damage Coverage** of the Business Auto Coverage Form and Paragraph **2.b.** in the **Exclusions** of **Section IV – Physical Damage Coverage** of the Motor Carrier Coverage Form:

This exclusion does not apply to covered "autos" participating in a driver safety program event, such as, but not limited to, auto or truck rodeos and other auto or truck agility demonstrations.

E. Lease or Loan Gap Coverage

The following is added to the **Coverage** Provision of the **Physical Damage Coverage** Section:

Lease Or Loan Gap Coverage

In the event of a total "loss" to a covered "auto", we will pay any unpaid amount due on the lease or loan for a covered "auto", less:

- a. Any amount paid under the **Physical Damage Coverage** Section of the Coverage Form; and
- b. Any:
 - (1) Overdue lease or loan payments at the time of the "loss";
 - (2) Financial penalties imposed under a lease for excessive use, abnormal wear and tear or high mileage;
 - (3) Security deposits not returned by the lessor;
 - (4) Costs for extended warranties, credit life insurance, health, accident or disability insurance purchased with the loan or lease; and
 - (5) Carry-over balances from previous leases or loans.

F. Towing and Labor

Paragraph **A.2.** of the **Physical Damage Coverage** Section is replaced by the following:

We will pay up to \$75 for towing and labor costs incurred each time a covered "auto" of the private passenger type is disabled. However, the labor must be performed at the place of disablement.

G. Extended Glass Coverage

The following is added to Paragraph **A.3.a.** of the **Physical Damage Coverage** Section:

If glass must be replaced, the deductible shown in the Declarations will apply. However, if glass can be repaired and is actually repaired rather than replaced, the deductible will be waived. You have the option of having the glass repaired rather than replaced.

H. Hired Auto Physical Damage – Increased Loss of Use Expenses

The **Coverage Extension** for **Loss Of Use Expenses** in the **Physical Damage Coverage** Section is replaced by the following:

Loss Of Use Expenses

For Hired Auto Physical Damage, we will pay expenses for which an "insured" becomes legally responsible to pay for loss of use of a vehicle rented or hired without a driver under a written rental contract or written rental agreement. We will pay for loss of use expenses if caused by:

- (1) Other than collision only if the Declarations indicate that Comprehensive Coverage is provided for any covered "auto";
 - (2) Specified Causes Of Loss only if the Declarations indicate that Specified Causes Of Loss Coverage is provided for any covered "auto"; or
 - (3) Collision only if the Declarations indicate that Collision Coverage is provided for any covered "auto".
- However, the most we will pay for any expenses for loss of use is \$100 per day, to a maximum of \$3000.

I. Personal Effects Coverage

The following is added to the **Coverage** Provision of the **Physical Damage Coverage** Section:

Personal Effects Coverage

- a. We will pay up to \$750 for "loss" to personal effects which are:
 - (1) Personal property owned by an "insured"; and
 - (2) In or on a covered "auto".
- b. Subject to Paragraph a. above, the amount to be paid for "loss" to personal effects will be based on the lesser of:
 - (1) The reasonable cost to replace; or
 - (2) The actual cash value.
- c. The coverage provided in Paragraphs a. and b. above, only applies in the event of a total theft of a covered "auto". No deductible applies to this coverage. However, we will not pay for "loss" to personal effects of any of the following:
 - (1) Accounts, bills, currency, deeds, evidence of debt, money, notes, securities, or commercial paper or other documents of value.
 - (2) Bullion, gold, silver, platinum, or other precious alloys or metals; furs or fur garments; jewelry, watches, precious or semi-precious stones.
 - (3) Paintings, statuary and other works of art.
 - (4) Contraband or property in the course of illegal transportation or trade.
 - (5) Tapes, records, discs or other similar devices used with audio, visual or data electronic equipment.

Any coverage provided by this Provision is excess over any other insurance coverage available for the same "loss".

J. Tapes, Records and Discs Coverage

1. The Exclusion in Paragraph **B.4.a.** of **Section III – Physical Damage Coverage** in the Business Auto Coverage Form and the Exclusion in Paragraph **B.2.c.** of **Section IV – Physical Damage Coverage** in the Motor Carrier Coverage Form does not apply.
2. The following is added to Paragraph **1.a. Comprehensive Coverage** under the **Coverage** Provision of the **Physical Damage Coverage** Section:

We will pay for "loss" to tapes, records, discs or other similar devices used with audio, visual or data electronic equipment. We will pay only if the tapes, records, discs or other similar audio, visual or data electronic devices:

- (a) Are the property of an "insured"; and
- (b) Are in a covered "auto" at the time of "loss".

The most we will pay for such "loss" to tapes, records, discs or other similar devices is \$500. The **Physical Damage Coverage Deductible** Provision does not apply to such "loss".

K. Airbag Coverage

The Exclusion in Paragraph **B.3.a.** of **Section III – Physical Damage Coverage** in the Business Auto Coverage Form and the Exclusion in Paragraph **B.4.a.** of **Section IV – Physical Damage Coverage** in the Motor Carrier Coverage Form does not apply to the accidental discharge of an airbag.

L. Two or More Deductibles

The following is added to the **Deductible** Provision of the **Physical Damage Coverage** Section:

If an accident is covered both by this policy or Coverage Form and by another policy or Coverage Form issued to you by us, the following applies for each covered "auto" on a per vehicle basis:

1. If the deductible on this policy or Coverage Form is the smaller (or smallest) deductible, it will be waived; or
2. If the deductible on this policy or Coverage Form is not the smaller (or smallest) deductible, it will be reduced by the amount of the smaller (or smallest) deductible.

M. Physical Damage – Comprehensive Coverage – Deductible

The following is added to the **Deductible** Provision of the **Physical Damage Coverage** Section:

Regardless of the number of covered "autos" damaged or stolen, the maximum deductible that will be applied to Comprehensive Coverage for all "loss" from any one cause is \$5,000 or the deductible shown in the Declarations, whichever is greater.

N. Temporary Substitute Autos – Physical Damage

1. The following is added to **Section I – Covered Autos**:

Temporary Substitute Autos – Physical Damage

If Physical Damage Coverage is provided by this Coverage Form on your owned covered "autos", the following types of vehicles are also covered "autos" for Physical Damage Coverage:

Any "auto" you do not own when used with the permission of its owner as a temporary substitute for a covered "auto" you do own but is out of service because of its:

1. Breakdown;
 2. Repair;
 3. Servicing;
 4. "Loss"; or
 5. Destruction.
2. The following is added to the Paragraph **A. Coverage** Provision of the **Physical Damage Coverage** Section:

Temporary Substitute Autos – Physical Damage

We will pay the owner for "loss" to the temporary substitute "auto" unless the "loss" results from fraudulent acts or omissions on your part. If we make any payment to the owner, we will obtain the owner's rights against any other party.

The deductible for the temporary substitute "auto" will be the same as the deductible for the covered "auto" it replaces.

O. Amended Duties In The Event Of Accident, Claim, Suit Or Loss

Paragraph **a.** of the **Duties In The Event Of Accident, Claim, Suit Or Loss** Condition is replaced by the following:

- a.** In the event of "accident", claim, "suit" or "loss", you must give us or our authorized representative prompt notice of the "accident", claim, "suit" or "loss". However, these duties only apply when the "accident", claim, "suit" or "loss" is known to you (if you are an individual), a partner (if you are a partnership), a member (if you are a limited liability company) or an executive officer or insurance manager (if you are a corporation). The failure of any

agent, servant or employee of the "insured" to notify us of any "accident", claim, "suit" or "loss" shall not invalidate the insurance afforded by this policy.

Include, as soon as practicable:

- (1) How, when and where the "accident" or "loss" occurred and if a claim is made or "suit" is brought, written notice of the claim or "suit" including, but not limited to, the date and details of such claim or "suit";
- (2) The "insured's" name and address; and
- (3) To the extent possible, the names and addresses of any injured persons and witnesses.

If you report an "accident", claim, "suit" or "loss" to another insurer when you should have reported to us, your failure to report to us will not be seen as a violation of these amended duties provided you give us notice as soon as practicable after the fact of the delay becomes known to you.

P. Waiver of Transfer Of Rights Of Recovery Against Others To Us

The following is added to the **Transfer Of Rights Of Recovery Against Others To Us** Condition:

This Condition does not apply to the extent required of you by a written contract, executed prior to any "accident" or "loss", provided that the "accident" or "loss" arises out of operations contemplated by such contract. This waiver only applies to the person or organization designated in the contract.

Q. Employee Hired Autos – Physical Damage

Paragraph **b.** of the **Other Insurance** Condition in the Business Auto Coverage Form and Paragraph **f.** of the **Other Insurance – Primary and Excess Insurance Provisions** Condition in the Motor Carrier Coverage Form are replaced by the following:

For Hired Auto Physical Damage Coverage, the following are deemed to be covered "autos" you own:

- (1) Any covered "auto" you lease, hire, rent or borrow; and
- (2) Any covered "auto" hired or rented under a written contract or written agreement entered into by an "employee" or elected or appointed official with your permission while being operated within the course and scope of that "employee's" employment by you or that elected or appointed official's duties as respect their obligations to you.

However, any "auto" that is leased, hired, rented or borrowed with a driver is not a covered "auto".

R. Unintentional Failure to Disclose Hazards

The following is added to the **Concealment, Misrepresentation Or Fraud** Condition:

However, we will not deny coverage under this Coverage Form if you unintentionally:

- (1) Fail to disclose any hazards existing at the inception date of this Coverage Form; or
- (2) Make an error, omission, improper description of "autos" or other misstatement of information.

You must notify us as soon as possible after the discovery of any hazards or any other information that was not provided to us prior to the acceptance of this policy.

S. Hired Auto – World Wide Coverage

Paragraph **7a.(5)** of the **Policy Period, Coverage Territory** Condition is replaced by the following:

- (5) Anywhere in the world if a covered "auto" is leased, hired, rented or borrowed for a period of 60 days or less,

T. Bodily Injury Redefined

The definition of "bodily injury" in the **Definitions** Section is replaced by the following:

"Bodily injury" means bodily injury, sickness or disease, sustained by a person including death or mental anguish, resulting from any of these at any time. Mental anguish means any type of mental or emotional illness or disease.

U. Expected Or Intended Injury

The **Expected Or Intended Injury** Exclusion in Paragraph **B. Exclusions** under **Section II – Covered Auto Liability Coverage** is replaced by the following:

Expected Or Intended Injury

"Bodily injury" or "property damage" expected or intended from the standpoint of the "insured". This exclusion does not apply to "bodily injury" or "property damage" resulting from the use of reasonable force to protect persons or property.

V. Physical Damage – Additional Temporary Transportation Expense Coverage

Paragraph **A.4.a.** of **Section III – Physical Damage Coverage** is replaced by the following:

4. Coverage Extensions

a. Transportation Expenses

We will pay up to \$50 per day to a maximum of \$1,000 for temporary transportation expense incurred by you because of the total theft of a covered "auto" of the private passenger type. We will pay only for those covered "autos" for which you carry either Comprehensive or Specified Causes of Loss Coverage. We will pay for temporary transportation expenses incurred during the period beginning 48 hours after the theft and ending, regardless of the policy's expiration, when the covered "auto" is returned to use or we pay for its "loss".

W. Replacement of a Private Passenger Auto with a Hybrid or Alternative Fuel Source Auto

The following is added to Paragraph **A. Coverage** of the **Physical Damage Coverage** Section:

In the event of a total "loss" to a covered "auto" of the private passenger type that is replaced with a hybrid "auto" or "auto" powered by an alternative fuel source of the private passenger type, we will pay an additional 10% of the cost of the replacement "auto", excluding tax, title, license, other fees and any aftermarket vehicle upgrades, up to a maximum of \$2500. The covered "auto" must be replaced by a hybrid "auto" or an "auto" powered by an alternative fuel source within 60 calendar days of the payment of the "loss" and evidenced by a bill of sale or new vehicle lease agreement.

To qualify as a hybrid "auto", the "auto" must be powered by a conventional gasoline engine and another source of propulsion power. The other source of propulsion power must be electric, hydrogen, propane, solar or natural gas, either compressed or liquefied. To qualify as an "auto" powered by an alternative fuel source, the "auto" must be powered by a source of propulsion power other than a conventional gasoline engine. An "auto" solely propelled by biofuel, gasoline or diesel fuel or any blend thereof is not an "auto" powered by an alternative fuel source.

X. Return of Stolen Automobile

The following is added to the **Coverage Extension** Provision of the **Physical Damage Coverage** Section:

If a covered "auto" is stolen and recovered, we will pay the cost of transport to return the "auto" to you. We will pay only for those covered "autos" for which you carry either Comprehensive or Specified Causes of Loss Coverage.

All other terms, conditions, provisions and exclusions of this policy remain the same.



Additional Insured – Automatic – Owners, Lessees Or Contractors

THIS ENDORSEMENT CHANGES THE POLICY. PLEASE READ IT CAREFULLY.

Policy No. GLA 0655100-01

Effective Date: 12/01/2021

This endorsement modifies insurance provided under the:

Commercial General Liability Coverage Part

A. Section II – Who Is An Insured is amended to include as an additional insured any person or organization whom you are required to add as an additional insured under a written contract or written agreement executed by you, but only with respect to liability for "bodily injury", "property damage" or "personal and advertising injury" and subject to the following:

1. If such written contract or written agreement specifically requires that you provide that the person or organization be named as an additional insured under one or both of the following endorsements:

- a. The Insurance Services Office (ISO) ISO CG 20 10 (10/01 edition); or
- b. The ISO CG 20 37 (10/01 edition),

such person or organization is then an additional insured with respect to such endorsement(s), but only to the extent that "bodily injury", "property damage" or "personal and advertising injury" arises out of:

- (1) Your ongoing operations, with respect to Paragraph 1.a. above; or
- (2) "Your work", with respect to Paragraph 1.b. above,
which is the subject of the written contract or written agreement.

However, solely with respect to this Paragraph 1., insurance afforded to such additional insured:

- (a) Only applies if the "bodily injury", "property damage" or "personal and advertising injury" offense occurs during the policy period and subsequent to your execution of the written contract or written agreement; and
- (b) Does not apply to "bodily injury" or "property damage" caused by "your work" and included within the "products-completed operations hazard" unless the written contract or written agreement specifically requires that you provide such coverage to such additional insured.

2. If such written contract or written agreement specifically requires that you provide that the person or organization be named as an additional insured under one or both of the following endorsements:

- a. The Insurance Services Office (ISO) ISO CG 20 10 (07/04 edition); or
- b. The ISO CG 20 37 (07/04 edition),

such person or organization is then an additional insured with respect to such endorsement(s), but only to the extent that "bodily injury", "property damage" or "personal and advertising injury" is caused, in whole or in part, by:

- (1) Your acts or omissions; or
- (2) The acts or omissions of those acting on your behalf,

in the performance of:

- (a) Your ongoing operations, with respect to Paragraph 2.a. above; or
- (b) "Your work" and included in the "products-completed operations hazard", with respect to Paragraph 2.b. above,

which is the subject of the written contract or written agreement.

However, solely with respect to this Paragraph 2., insurance afforded to such additional insured:

- (i) Only applies if the "bodily injury", "property damage" or "personal and advertising injury" offense occurs during the policy period and subsequent to your execution of the written contract or written agreement; and
 - (ii) Does not apply to "bodily injury" or "property damage" caused by "your work" and included within the "products-completed operations hazard" unless the written contract or written agreement specifically requires that you provide such coverage to such additional insured.
3. If neither Paragraph 1. nor Paragraph 2. above apply and such written contract or written agreement requires that you provide that the person or organization be named as an additional insured:

- a. Under the ISO CG 20 10 (04/13 edition, any subsequent edition or if no edition date is specified); or
- b. With respect to ongoing operations (if no form is specified),

such person or organization is then an additional insured only to the extent that "bodily injury", "property damage" or "personal and advertising injury" is caused, in whole or in part by:

- (1) Your acts or omissions; or
- (2) The acts or omissions of those acting on your behalf,

in the performance of your ongoing operations, which is the subject of the written contract or written agreement.

However, solely with respect to this Paragraph 3., insurance afforded to such additional insured:

- (a) Only applies to the extent permitted by law;
- (b) Will not be broader than that which you are required by the written contract or written agreement to provide for such additional insured; and
- (c) Only applies if the "bodily injury", "property damage" or "personal and advertising injury" offense occurs during the policy period and subsequent to your execution of the written contract or written agreement.

4. If neither Paragraph 1. nor Paragraph 2. above apply and such written contract or written agreement requires that you provide that the person or organization be named as an additional insured:

- a. Under the ISO CG 20 37 (04/13 edition, any subsequent edition or if no edition date is specified); or
- b. With respect to the "products-completed operations hazard" (if no form is specified),

such person or organization is then an additional insured only to the extent that "bodily injury" or "property damage" is caused, in whole or in part by "your work" and included in the "products-completed operations hazard", which is the subject of the written contract or written agreement.

However, solely with respect to this Paragraph 4., insurance afforded to such additional insured:

- (1) Only applies to the extent permitted by law;
- (2) Will not be broader than that which you are required by the written contract or written agreement to provide for such additional insured;
- (3) Only applies if the "bodily injury" or "property damage" occurs during the policy period and subsequent to your execution of the written contract or written agreement; and
- (4) Does not apply to "bodily injury" or "property damage" caused by "your work" and included within the "products-completed operations hazard" unless the written contract or written agreement specifically requires that you provide such coverage to such additional insured.

- B. Solely with respect to the insurance afforded to any additional insured referenced in Section A. of this endorsement, the following additional exclusion applies:

This insurance does not apply to "bodily injury", "property damage" or "personal and advertising injury" arising out of the rendering of, or failure to render, any professional architectural, engineering or surveying services including:

1. The preparing, approving or failing to prepare or approve maps, shop drawings, opinions, reports, surveys, field orders, change orders or drawings and specifications; or
2. Supervisory, inspection, architectural or engineering activities.

This exclusion applies even if the claims against any insured allege negligence or other wrongdoing in the supervision, hiring, employment, training or monitoring of others by that insured, if the "occurrence" which caused the "bodily injury" or "property damage", or the offense which caused the "personal and advertising injury", involved the rendering of or the failure to render any professional architectural, engineering or surveying services.

- C. Solely with respect to the coverage provided by this endorsement, the following is added to Paragraph 2. **Duties In The Event Of Occurrence, Offense, Claim Or Suit** of Section IV – **Commercial General Liability Conditions**:

The additional insured must see to it that:

- (1) We are notified as soon as practicable of an "occurrence" or offense that may result in a claim;
- (2) We receive written notice of a claim or "suit" as soon as practicable; and
- (3) A request for defense and indemnity of the claim or "suit" will promptly be brought against any policy issued by another insurer under which the additional insured may be an insured in any capacity. This provision does not apply to insurance on which the additional insured is a Named Insured if the written contract or written agreement requires that this coverage be primary and non-contributory.

- D. Solely with respect to the coverage provided by this endorsement:

1. The following is added to the **Other Insurance** Condition of Section IV – **Commercial General Liability Conditions**:

Primary and Noncontributory insurance

This insurance is primary to and will not seek contribution from any other insurance available to an additional insured provided that:

- a. The additional insured is a Named Insured under such other insurance; and
- b. You are required by written contract or written agreement that this insurance be primary and not seek contribution from any other insurance available to the additional insured.

2. The following paragraph is added to Paragraph 4.b. of the **Other Insurance** Condition under Section IV – **Commercial General Liability Conditions**:

This insurance is excess over:

Any of the other insurance, whether primary, excess, contingent or on any other basis, available to an additional insured, in which the additional insured on our policy is also covered as an additional insured on another policy providing coverage for the same "occurrence", offense, claim or "suit". This provision does not apply to any policy in which the additional insured is a Named Insured on such other policy and where our policy is required by a written contract or written agreement to provide coverage to the additional insured on a primary and non-contributory basis.

- E. This endorsement does not apply to an additional insured which has been added to this Coverage Part by an endorsement showing the additional insured in a Schedule of additional insureds, and which endorsement applies specifically to that identified additional insured.

- F. Solely with respect to the insurance afforded to an additional insured under Paragraph A.3. or Paragraph A.4. of this endorsement, the following is added to Section III – **Limits Of Insurance**:

Additional Insured – Automatic – Owners, Lessees Or Contractors Limit

The most we will pay on behalf of the additional insured is the amount of insurance:

1. Required by the written contract or written agreement referenced in Section **A.** of this endorsement; or
2. Available under the applicable Limits of Insurance shown in the Declarations,
whichever is less.

This endorsement shall not increase the applicable Limits of Insurance shown in the Declarations.

All other terms, conditions, provisions and exclusions of this policy remain the same.



DIVISION OF FACILITIES PLANNING & MANAGEMENT ROUTING FORM

Project Information

Project Name	Claremont Middle School Multi-purpose Room & Kitchen	Site	201
---------------------	--	-------------	-----

Basic Directions

Services cannot be provided until the contract is awarded by the Board or is entered by the Superintendent pursuant to authority delegated by the Board.	
Attachment Checklist	<input checked="" type="checkbox"/> Proof of general liability insurance, including certificates and endorsements, if contract is over \$15,000. <input checked="" type="checkbox"/> Workers compensation insurance certification, unless vendor is a sole provider

Contractor Information

Contractor Name	ARNTZ BUILDERS, INC.	Agency's Contact	Brian Proteau				
OUSD Vendor ID #	000493	Title					
Street Address	431 Payran Street	City	Petaluma	State	CA	Zip	94952
Telephone	707-835-2900	Policy Expires					
Contractor History	Previously been an OUSD contractor? <input checked="" type="checkbox"/> Yes <input type="checkbox"/> No		Worked as an OUSD employee? <input type="checkbox"/> Yes <input checked="" type="checkbox"/> No				
OUSD Project #	15127						

Term of Original/Amended Contract

Date Work Will Begin (i.e., effective date of contract)	6-23-2022	Date Work Will End By (not more than 5 years from start date; for construction contracts, enter planned completion date)	8-31-2023
		New Date of Contract End (If Any)	

Compensation/Revised Compensation

If New Contract, Total Contract Price (Lump Sum)	\$15,985,725.00	If New Contract, Total Contract Price (Not To Exceed)	\$
Pay Rate Per Hour (If Hourly)	\$	If Amendment, Change in Price	\$
Other Expenses		Requisition Number	

Budget Information

If you are planning to multi-fund a contract using LEP funds, please contact the State and Federal Office before completing requisition.

Resource #	Funding Source	Org Key	Object Code	Amount
9655/9670	Fund 21, Measure Y	210-9655-0-9670-8500-6271-201-9180-9906-9999-15127	6271	\$15,985,725.00

Approval and Routing (in order of approval steps)

Services cannot be provided before the contract is fully approved and a Purchase Order is issued. Signing this document affirms that to your knowledge services were not provided before a PO was issued.

	Division Head	Phone	510-535-7038	Fax	510-535-7082
1.	Executive Director, Facilities Planning and Management				
	Signature	Date Approved	5-5-2022		
2.	General Counsel, Department of Facilities Planning and Management				
	Signature Lozano Smith, approved as to form (limited)	Date Approved	5/5/22		
3.	Deputy Chief, Facilities Planning and Management				
	Signature	Date Approved	5/5/2022		
4.	Chief Financial Officer				
	Signature	Date Approved			
5.	President, Board of Education				
	Signature	Date Approved			