

Board Office Use: Legislative File Info.	
File ID Number	15- 0326
Introduction Date	3-11-2015
Enactment Number	15-0297
Enactment Date	3/11/15 <i>MS</i>



Memo

To Board of Education

From Antwan Wilson, Superintendent and Secretary, Board of Education
 By: Mia Settles-Tidwell, Chief Operations Officer *MS*
 Timothy White, Deputy Chief, Facilities Planning and Management *MS*

Board Meeting Date March 11, 2015

Subject Small Construction Contract - DKB, Inc. - Metwest Educational Center Project

Action Requested Approval by the Board of Education of a Small Construction Contract with DKB, Inc. for Construction Services on behalf of the District at the Metwest Educational Center Project, in an amount not-to exceed \$9,886.00. The term of this Agreement shall commence on March 11, 2015 and shall conclude no later than June 11, 2015.

Background The original plans showed a one hour rated shaftwall in the Custodian Room A-246 but was not constructed properly. ASI #64 is a correction to fire rate the vertical duct.

Local Business Participation Percentage 0.00% (Specialty Service)

Strategic Alignment Among the key purposes of the District's Facilities Master Plan is to provide an academic environment for the Oakland community that will give every student, educator, and community member using our facilities the best possible opportunity for learning.

Through implementation of the Facilities Master Plan, the District intends to improve the District's facilities in terms of structural integrity, safety, reliability of operating (mechanical) systems, access to modern resources, number and type of appropriate laboratories and specialized instruction rooms, opportunities for physical education, and attractiveness, such that the Oakland Public Schools are second to none. Operation of the District schools under the planned approach is intended to ensure safety, cleanliness, and orderliness for all individuals participating in the learning process.

The basic facility needs of students such as proper lighting, functional roofs, noise control and well maintained buildings, not only convey the message that we value our students and teachers but may foster a sense of school pride and community ownership which may improve attitudes towards learning. The implementation of the Facilities Master Plan is our first step in that direction.

Recommendation

Approval by the Board of Education of a Small Construction Contract with DKB, Inc. for Construction Services on behalf of the District at the Metwest Educational Center Project, in an amount not-to exceed \$9,886.00. The term of this Agreement shall commence on March 11, 2015 and shall conclude no later than June 11, 2015.

Fiscal Impact

County School Facilities Fund

Attachments

- Independent Consultant Agreement including scope of work
- Contractor Proposal
- Certificate of Insurance

CONTRACT FOR REPAIRS, MAINTENANCE OR SMALL CONSTRUCTION PROJECTS

For

- REPAIRS, MAINTENANCE OR CONSTRUCTION SERVICES AWARDED PURSUANT TO THE "INFORMAL BIDDING" PROCEDURES OF THE PUBLIC CONTRACT CODE § 22000, ET SEQ. (THE UNIFORM PUBLIC CONSTRUCTION COST ACCOUNTING ACT ("CUPCAA"))
- or
- REPAIRS, MAINTENANCE OR CONSTRUCTION SERVICES UNDER \$45,000 AWARDED PURSUANT TO CUPCAA

CONTRACT NUMBER 07047

THIS CONTRACT is made and entered into this **29th day of December, 2014** ("Contract"), by and between **DKB, Inc.** ("Contractor") and Oakland Unified School District ("District"). Contractor and District may be referred to herein individually as a "Party" or collectively as the "Parties."

1. The Contractor shall furnish to the District for a total price of **Nine thousand, eight hundred eighty-six dollars and eighty cents (\$9,886.80)**, the following repairs, maintenance or construction services ("Services" or "Work"):

The scope of the project is for the contractor to furnish materials and labor required to install 3M fire rated blanket around vertical duct at 2nd floor custodian room (A-246) per ASI #64 shaftwall correction. Proposal includes 10% contingency (\$898.80)

2. Contractor shall perform the Work at **DKB, Inc.** ("Premises" or "Site"). The Project is the scope of Work performed at the Site.
3. Work shall be completed within **Ninety days (90)** consecutive calendar days from **March 11, 2015 through June 11, 2015** ("Contract Time") from the date specified in the District's Notice to Proceed. Contractor agrees that if the Work is not completed within the Contract Time and/or pursuant to the completion schedule, construction schedule, or project milestones developed pursuant to provisions of the Contract, it is understood, acknowledged, and agreed that the District will suffer damage which is not capable of being calculated. Pursuant to Government Code section 53069.85, Contractor shall pay to the District, as fixed and liquidated damages for these incalculable damages, the sum of **NA** per day for each and every calendar day of delay beyond the Contract Time or beyond any completion schedule, construction schedule, or Project milestones established pursuant to the Contract.
4. Contractor shall not commence the Work under this Contract until Contractor has submitted and District has approved the performance bond, payment (labor and material) bond(s), the certificate(s) and affidavit(s), and the endorsement(s) of insurance required under the Terms and Conditions and the District has issued a Notice to Proceed.
5. Payment for the Work shall be made in accordance with the Terms and Conditions attached hereto.
6. Inspection and acceptance of the Work shall be performed by Saya Nhim of the Division

7. This Contract incorporates by this reference the Terms and Conditions attached hereto. The Contractor, by executing this Contract, agrees to comply with the Terms and Conditions.

8. The Contract Documents include only the following documents, as indicated:

- | | | |
|---|-------------------------------------|--|
| Instructions to Bidders | <input checked="" type="checkbox"/> | Asbestos & Other Hazardous Materials Certification |
| Bid Form and Proposal | | |
| Bid Bond | <input checked="" type="checkbox"/> | Lead-Product(s) Certification |
| <input checked="" type="checkbox"/> Designated Subcontractors List | <input checked="" type="checkbox"/> | Insurance Certificates and Endorsements |
| <input checked="" type="checkbox"/> Notice to Proceed | <input checked="" type="checkbox"/> | Debarment Certification |
| <input checked="" type="checkbox"/> Terms and Conditions to Contract | <input checked="" type="checkbox"/> | Performance Bond |
| <input checked="" type="checkbox"/> Non-collusion Affidavit | <input checked="" type="checkbox"/> | Payment Bond |
| <input checked="" type="checkbox"/> Prevailing Wage Certification | <input checked="" type="checkbox"/> | Exhibit "A" ("Scope of Work") |
| <input checked="" type="checkbox"/> Workers' Compensation Certification | <input checked="" type="checkbox"/> | Plans |
| <input checked="" type="checkbox"/> Criminal Background Investigation Certification | <input checked="" type="checkbox"/> | Work Specifications |
| <input checked="" type="checkbox"/> Drug-Free Workplace Certification | | _____ [Other] |
| | | _____ [Other] |

9. The architect for the Project is **NA** ("Architect") and the project manager on the Project is **Saya Nhim** ("Project Manager").

10. Contractor shall guarantee all labor and material used in the performance of this Contract for a period of one year from the date of the District's written approval of the Work.

11. By signing this Agreement, Contractor certifies, under penalty of perjury, that all the information provided in the Contract Documents is true, complete, and correct.

Certification Regarding Debarment, Suspension, Ineligibility and Voluntary Exclusion: The District certifies to the best of its knowledge and belief, that it and its officials: Are not presently debarred, suspended, proposed for debarment, declared ineligible, or voluntarily excluded from covered transactions by any Federal department or agency according to Federal Acquisition Regulation Subpart 9.4, and by signing this contract, certifies that this vendor does not appear on the Excluded Parties List.

<https://www.sam.gov/portal/public/SAM>

Susie Butler-Berkley
Contract Analyst

ACCEPTED AND AGREED on the date indicated below:

OAKLAND UNIFIED SCHOOL DISTRICT

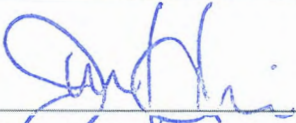
James Harris, President, Board of Education 3/12/15
Date

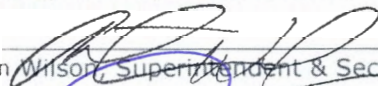
Antwan Wilson, Superintendent & Secretary, Board of Education 3/12/15
Date

Timothy White, Deputy Chief, Facilities Planning and Management 2/11/15
Date

APPROVED AS TO FORM:

OUSD Facilities Legal Counsel 2-7-15
Date

CONTRACTOR

DKB, Inc.

3/2/2015
Date

File ID Number: 15-0326
Introduction Date: 3/11/15
Enactment Number: 15-0097
Enactment Date: 3/11/15
By: 02

Information regarding Contractor:

Contractor: DKB, Inc
License No.: 987151
Address: 702 N California
Pasco WA 99301
Telephone: 509-545-3885
Facsimile: 509 545 3880
E-Mail: dburows@dkbinc.net

Type of Business Entity:
 Individual
 Sole Proprietorship
 Partnership
 Limited Partnership
 Corporation, State: Washington
 Limited Liability Company
 Other: _____

91-1909638
Employer Identification and/or Social Security Number

NOTE: Title 26, Code of Federal Regulations, sections 6041 and 6209 require non-corporate recipients of \$600.00 or more to furnish their taxpayer identification number to the payer. The regulations also provide that a penalty may be imposed for failure to furnish the taxpayer identification number. In order to comply with these regulations, the District requires your federal tax identification number or Social Security number, whichever is applicable.

TERMS AND CONDITIONS TO CONTRACT

1. **NOTICE TO PROCEED:** District shall provide a Notice to Proceed to Contractor pursuant to the Contract at which time Contractor shall proceed with the Work.
2. **SITE EXAMINATION:** Contractor has examined the Site and certifies that it accepts all measurements, specifications and conditions affecting the Work to be performed at the Site. By submitting its quote, Contractor warrants that it has made all Site examination(s) that it deems necessary as to the condition of the Site, its accessibility for materials, workers and utilities, and Contractor's ability to protect existing surface and subsurface improvements. No claim for allowance of time or money will be allowed as to any other undiscovered condition on the Site.
3. **EQUIPMENT AND LABOR:** The Contractor shall furnish all tools, equipment, apparatus, facilities, transportation, labor, and material necessary to furnish the Services, the Services to be performed at such times and places as directed by and subject to the approval of the authorized District representative indicated in the Work specifications attached hereto.
4. **LOCAL, SMALL LOCAL AND SMALL LOCAL RESIDENT BUSINESS ENTERPRISE PROGRAM (L/SL/SLRBE).** Contractor shall comply with the requirements of the District's L/SL/SLRBE Program, as applicable, which may require a fifty percent (50%) mandatory minimum local participation requirements in the performance of this Agreement. A copy of the District's L/SL/SLRBE Program can be obtained on the District's website at www.ousd.k12.ca.us, under the Facilities Planning & Management Department drop down menu, Bids and Request for Proposals.
5. **SUBCONTRACTORS:** Contractor shall comply with the Subletting and Subcontracting Fair Practices Act (Public Contract Code, section 4100 et. seq.) Contractor shall identify the name, the location of the place of business, the California contractor license number, and kind of work of each subcontractor who will perform work or labor or render service in or about the construction of the Project in an amount in excess of one-half of 1 percent of the Contractor's contract price or ten thousand dollars (\$10,000) whichever is greater. Subcontractors, if any, engaged by the Contractor for any Service or Work under this Contract shall be subject to the approval of the District. Contractor agrees to bind every subcontractor by the terms of the Contract as far as such terms are applicable to subcontractor's work, including, without limitation, all indemnification, insurance, bond, and warranty requirements. If Contractor subcontracts any part of this Contract, Contractor shall be fully responsible to the District for acts and omissions of its subcontractor and of persons either directly or indirectly employed by itself. Nothing contained in the Contract Documents shall create any contractual relations between any subcontractor and the District.
6. **TERMINATION:** If Contractor fails to perform the Services and Contractor's duties to the satisfaction of the District, or if Contractor fails to fulfill in a timely and professional manner Contractor's obligations under this Contract, or if Contractor violates any of the terms or provisions of this Contract, the District shall have the right to terminate this Contract effective immediately upon the District giving written notice thereof to the Contractor. District shall also have the right in its sole discretion to terminate the Contract for its own convenience. Termination shall have no effect upon any of the rights and obligations of the parties arising out of any transaction occurring prior to the effective date of termination.
7. **SAFETY AND SECURITY:** Contractor is responsible for maintaining safety in the performance of this Contract. Contractor shall be responsible for complying with the District's the rules and regulations pertaining to safety, security, and driving on school grounds, particularly when children are present.

8. **CHANGE IN SCOPE OF WORK:** Any change in the scope of the Work, method of performance, nature of materials or price thereof, or any other matter materially affecting the performance or nature of the Work shall not be paid for or accepted by District unless such change, addition, or deletion is approved in advance and in writing by a valid change order executed by the District. Contractor specifically understands, acknowledges, and agrees that the District shall have the right to request any alterations, deviations, reductions, or additions to the Project or Work, and the cost thereof shall be added to or deducted from the amount of the Contract Price by fair and reasonable valuations. Contractor also agrees to provide the District with all information requested to substantiate the cost of any change order and to inform the District whether the Work will be done by the Contractor or a subcontractor. In addition to any other information requested, Contractor shall submit, prior to approval of any change order, its request for a time extension (if any), as well as all information necessary to substantiate Contractor's belief that such change will delay the completion of the Work. If Contractor fails to submit its request for a time extension or the necessary supporting information, it shall be deemed to have waived its right to request such extension.
9. **TRENCH SHORING:** If this Contract is in excess of \$25,000 and is for the excavation of any trench deeper than five (5) feet, Contractor must submit and obtain District's approval and acceptance, in advance of excavation, of a detailed plan showing the design of shoring, bracing, sloping, or other provisions to be made for worker protection from the hazard of caving ground during the excavation of such trench or trenches. If the plan varies from the shoring system standards, the plan shall be prepared by a registered civil or structural engineer.
10. **EXCAVATIONS OVER FOUR FEET:** If this Contract includes excavations over four (4) feet, Contractor shall promptly, and before the following conditions are disturbed, notify the District, in writing, of any: (1) Material that the Contractor believes may be material that is hazardous waste, as defined in Section 25117 of the Health and Safety Code, that is required to be removed to a Class I, Class II, or Class III disposal site in accordance with provisions of existing law; (2) Subsurface or latent physical conditions at the Site differing from those indicated; or (3) Unknown physical conditions at the Site of any unusual nature, different materially from those ordinarily encountered and generally recognized as inherent in work of the character provided for in the Contract. The District shall promptly investigate the conditions, and if it finds that the conditions do materially so differ, or do involve hazardous waste, and cause a decrease or increase in the Contractor's cost of, or the time required for, performance of any part of the Work shall issue a change order under the procedures described in the Contract. In the event that a dispute arises between the District and the Contractor regarding whether the conditions materially differ, or involve hazardous waste, or cause a decrease or increase in the Contractor's cost of, or time required for, performance of any part of the work, the Contractor shall not be excused from any scheduled completion date provided for by the Contract, but shall proceed with all Work. Contractor shall retain any and all rights provided either by Contract or by law which pertain to the resolution of disputes and protests between the contracting parties.
11. **LEAD-BASED PAINT:** Pursuant to the Lead-Safe Schools Protection Act (Education Code Section 32240 et seq.) and other applicable law, no lead-based paint, lead plumbing and solders, or other potential sources of lead contamination shall be utilized on this Project, and only trained and state-certified contractors, inspectors and workers shall undertake any action to abate existing risk factors for lead. Contractor must execute the Lead-Based Paint Certification, if applicable.
12. **WORKERS:** Contractor shall at all times enforce strict discipline and good order among its employees and the employees of its subcontractors and shall not employ or work any unfit person or anyone not skilled in work assigned to him or her. Any person in the

employ of the Contractor or a subcontractor whom the District may deem incompetent or unfit shall be dismissed from the Site and shall not again be employed at Site without written consent from the District.

13. **CORRECTION OF ERRORS:** Contractor shall perform, at its own cost and expense and without reimbursement from the District, any work necessary to correct errors or omissions which are caused by the Contractor's failure to comply with the standard of care required herein.
14. **SUBSTITUTIONS:** No substitutions of material from those specified in the Work Specifications shall be made without the prior written approval of the District.
15. **CONTRACTOR SUPERVISION:** Contractor shall provide competent supervision of personnel employed on the job Site, use of equipment, and quality of workmanship,
16. **CLEAN UP:** Debris shall be removed from the Premises. The Site shall be in order at all times when work is not actually being performed and shall be maintained in a reasonably clean condition.
17. **ACCESS TO WORK:** District representatives shall at all time have access to the Work wherever it is in preparation or in progress. Contractor shall provide safe and proper facilities for such access.
18. **PROTECTION OF WORK AND PROPERTY:** Contractor shall erect and properly maintain at all times, as required by conditions and progress of the Work, all necessary safeguards, signs, barriers, lights, and security persons for protection of workers and the public, and shall post danger signs warning against hazards created by the Work. In an emergency affecting life and safety of life or of Work or of adjoining property, Contractor, without special instruction or authorization from District, is permitted to act at his discretion to prevent such threatened loss or injury.
19. **ASSIGNMENT OF CONTRACT:** Contractor shall not assign or transfer in any way any or all of its rights, burdens, duties, or obligations under this Contract without the prior written consent of the District.
20. **TIME IS OF THE ESSENCE:** Time is of the essence in the performance of and compliance with each of the provisions and conditions of this Contract.
21. **OCCUPANCY:** District reserves the right to occupy buildings at any time before formal Contract completion and such occupancy shall not constitute final acceptance or approval of any part of the Work covered by this Contract, nor shall such occupancy extend the date specified for completion of the Work.
22. **FORCE MAJEURE CLAUSE:** Contractor shall be excused from performance hereunder during the time and to the extent that it is prevented from obtaining delivery, or performing by act of God, fire, strike, loss, or shortage of transportation facilities, lock-out, commandeering of materials, product, plant, or facilities by the government, when satisfactory evidence thereof is presented to the District, provided that it is satisfactorily established that the non-performance is not due to the fault or neglect of Contractor.
23. **INDEMNIFICATION / HOLD HARMLESS CLAUSE:** To the furthest extent permitted by California law, Contractor shall defend, indemnify, and hold harmless the District, their agents, representatives, officers, consultants, employees, and volunteers (the "indemnified parties") from any and all demands, losses, liabilities, claims, suits, and actions (the "claims") of any kind, nature, and description, including, but not limited to, attorneys' fees and costs, directly or indirectly arising from personal or bodily injuries, death, property damage, or otherwise arising out of, connected with, or resulting from the performance of this Contract unless the claims are caused wholly by the sole negligence or willful misconduct of the indemnified parties. The District shall have the

right to accept or reject any legal representation that Contractor proposes to defend the District.

24. **PAYMENT:** On a monthly basis, Contractor shall submit an application for payment based upon the estimated value for materials delivered or services performed under the Contract as of the date of submission ("Application for Payment"). Within thirty (30) days after District's approval of the Application for Payment, Contractor shall be paid a sum equal to ninety percent (90%) of the value of the Work performed (as verified by Architect and Inspector and certified by Contractor) up to the last day of the previous month, less the aggregate of previous payments and amount to be withheld. The District may deduct from any payment an amount necessary to protect the District from loss because of: (1) liquidated damages which have accrued as of the date of the application for payment; (2) any sums expended by the District in performing any of Contractor's obligations under the Contract which Contractor has failed to perform or has performed inadequately; (3) defective Work not remedied; (4) stop notices as allowed by state law; (5) reasonable doubt that the Work can be completed for the unpaid balance of the Total Contract price or by the scheduled completion date; (6) unsatisfactory prosecution of the Work by Contractor; (7) unauthorized deviations from the Contract; (8) failure of the Contractor to maintain or submit on a timely basis proper and sufficient documentation as required by the Contract or by District during the prosecution of the Work; (9) erroneous or false estimates by the Contractor of the value of the Work performed; (10) any sums representing expenses, losses, or damages, as determined by the District, incurred by the District for which Contractor is liable under the Contract; and (11) any other sums which the District is entitled to recover from Contractor under the terms of the Contract or pursuant to state law, including section 1727 of the California Labor Code. The failure by the District to deduct any of these sums from a progress payment shall not constitute a waiver of the District's right to such sums. The District shall retain ten percent (10%) from all amounts owing as retention. Retention shall be paid pursuant to Public Contract Code sections 7107 and 7200.
25. **PERMITS AND LICENSES:** Contractor and all of its employees, agents, and subcontractors shall secure and maintain in force, at Contractor's sole cost and expense, all licenses and permits as are required by law, in connection with the furnishing of materials, supplies, or Services herein listed.
26. **INDEPENDENT CONTRACTOR STATUS:** While engaged in carrying out the Services of this Contract, the Contractor is an independent contractor, and not an officer, employee, agent, partner, or joint venture of the District. Contractor shall be solely responsible for its own Worker's Compensation insurance, taxes, and other similar charges or obligations. Contractor shall be liable for its own actions, including its negligence or gross negligence, and shall be liable for the acts, omissions, or errors of its agents or employees.
27. **ANTI-DISCRIMINATION:** It is the policy of the District that in connection with all work performed under contracts there be no discrimination against any employee engaged in the work because of race, color, ancestry, national origin, or religious creed, and therefore the Contractor agrees to comply with applicable Federal and California laws including, but not limited to the California Fair Employment Practice Act beginning with Government Code Section 12900 and Labor Code Section 1735. In addition, the Contractor agrees to require like compliance by all its subcontractor(s).
28. **DISABLED VETERAN BUSINESS ENTERPRISES:** Section 17076.11 of the Education Code requires school districts using funds allocated pursuant to the State of California School Facility Program for the construction or modernization of a school building (SFP Funds) to have a participation of at least three percent (3%), per year, of the overall

dollar amount expended each year by the school district, for disabled veteran business enterprises (DVBE). If this Contract uses School Facilities Program Funds, Contractor must submit, with its executed Contract, appropriate documentation to the District identifying the steps Contractor has taken to solicit DVBE participation in conjunction with this Contract.

29. **PAYMENT BOND AND PERFORMANCE BOND:** Contractor shall not commence the Work until it has provided to the District a Payment (Labor and Material) Bond and a Performance Bond, in the forms attached hereto, each in an amount equivalent to one hundred percent (100%) of the Contract Price issued by a surety admitted to issue bonds in the State of California and otherwise acceptable to the District.
30. **CONTRACTOR'S INSURANCE:** Contractor shall have and maintain in force during the term of this Contract, with the minimum indicated limits, the following insurance: **Commercial General Liability insurance:** \$1,000,000 for each occurrence and general aggregate with Products and Completed Operations Coverage; **Automobile Liability – Any Auto:** combined single limit of \$1,000,000; **Excess Liability insurance:** \$4,000,000; **Workers Compensation:** Statutory limits; and **Employers' Liability:** \$1,000,000. Contractor shall provide to the District certificate(s) of insurance and endorsements satisfactory to the District. The policy(ies) shall not be amended or modified and the coverage amounts shall not be reduced without thirty (30) days written notice to the District prior to cancellation. Except for worker's compensation insurance, the District, the Architect, and the Project Manager shall be named as an additional insured on all policies. Contractor's policy(ies) shall be primary; any insurance carried by the District shall only be secondary and supplemental. Contractor shall not allow any subcontractor, employee, or agent to commence Work on this Contract or any subcontract until the insurance required of Contractor, subcontractor, or agent has been obtained.
31. **WARRANTY/QUALITY:** Unless a longer warranty is called for elsewhere in the Contract Documents, Contractor, manufacturer, or their assigned agents shall guarantee the workmanship, product or Services performed against defective workmanship, defects or failures of materials for a minimum period of one (1) year from filing the Notice of Completion with the county in which the Site is located. All workmanship and merchandise must be warranted to be in compliance with applicable California energy, conservation, environmental, and educational standards.
32. **CONFIDENTIALITY:** Contractor shall maintain the confidentiality of all information, documents, programs, procedures, and all other items that Contractor encounters while performing the Contractor's Services to the extent allowed by law. This requirement shall be ongoing and shall survive the expiration or termination of this Contract and specifically includes all student, parent, and disciplinary information.
33. **COMPLIANCE WITH LAWS:** Contractor shall give all notices and comply with all laws, ordinance, rules and regulations bearing on conduct of the Work as indicated or specified. If Contractor observes that any of the Work required by this Contract is at variance with any such laws, ordinance, rules or regulations, Contractor shall notify the District, in writing, and, at the sole option of the District, any necessary changes to the scope of the Work shall be made and this Contract shall be appropriately amended in writing, or this Contract shall be terminated effective upon Contractor's receipt of a written termination notice from the District. If Contractor performs any work that is in violation of any laws, ordinances, rules or regulations, without first notifying the District of the violation, Contractor shall bear all costs arising therefrom.
34. **DISPUTES:** In the event of a dispute between the Parties as to performance of the Work, the interpretation of this Contract, or payment or nonpayment for Work performed or not performed, the Parties shall attempt to resolve the dispute by those

procedures set forth in Public Contract Code section 20104, et seq., if applicable. Pending resolution of the dispute, Contractor agrees it will neither rescind the Contract nor stop the progress of the Work, but will allow determination by the court of the State of California, in the county in which the District's administration office is located, having competent jurisdiction of the dispute. All claims over Three Hundred Seventy-Five Thousand Dollars (\$375,000), which are outside the scope of Public Contract Code section 20104, et seq., may be determined by independent arbitration if mutually agreeable, otherwise by litigation.

- Notice of the demand for arbitration of a dispute shall be filed in writing with the other Party.
 - The demand for arbitration of any claim of over Three Hundred Seventy-five Thousand Dollars (\$375,000) shall be made within a reasonable time after written notice of the dispute has been provided to the other Party, but in no case longer than ninety (90) days after initial written notice, and the demand shall not be made later than the time of Contractor submission of the request for final payment.
35. **LABOR CODE REQUIREMENTS:** Contractor shall comply with all applicable provisions of the California Labor Code, Division 3, Part 7, Chapter 1, Articles 1-5, including, without limitation, the payment of the general prevailing per diem wage rates for public work projects of more than one thousand dollars (\$1,000). Copies of the prevailing rate of per diem wages are on file with the District. Contractor specifically acknowledges and understands that if the District and/or its designee operates a labor compliance program on this Project, that Contractor shall perform the Work of the Project while complying with all the applicable provisions of the District's labor compliance program. In addition, Contractor and each subcontractor shall comply with Chapter 1 of Division 2, Part 7 of the California Labor Code, beginning with Section 1720, and including Section 1735, 1777.5 and 1777.6, forbidding discrimination, and Sections 1776, 1777.5 and 1777.6 concerning the employment of apprentices by Contractor or subcontractors. Willful failure to comply may result in penalties, including loss of the right to bid on or receive public works contracts.
36. **Certified Payroll Records:** Contractor and its subcontractor(s) shall keep accurate certified payroll records of employees and shall make them available to the District immediately upon request.
37. **ANTI-TRUST CLAIM:** Contractor and its subcontractor(s) agree to assign to the District all rights, title, and interest in and to all causes of action they may have under Section 4 of the Clayton Act (15 U.S.C. Sec. 15) or under the Cartwright Act (Chapter 2 (commencing with Section 16700) of Part 2 of Division 7 of the Business and Professions Code), arising from purchases of goods, services, or materials pursuant to the Contract or a subcontract. This assignment shall be made and become effective at the time the District tenders final payment to the Contractor, without further acknowledgment by the Parties.
38. **GOVERNING LAW:** This Contract shall be governed by and construed in accordance with the laws of the State of California with venue of any action in a in the county in which the District's administration office is located.
39. **PROVISIONS REQUIRED BY LAW DEEMED INSERTED:** Each and every provision of law and clause required by law to be inserted in this Contract shall be deemed to be inserted herein and this Contract shall be read and enforced as though it were included therein.
40. **BINDING CONTRACT:** This Contract shall be binding upon the Parties hereto and upon their successors and assigns, and shall inure to the benefit of the Parties and their successors and assigns.

41. **DISTRICT WAIVER:** District's waiver of any term, condition, covenant or waiver of a breach of any term, condition or covenant shall not constitute the waiver of any other term, condition or covenant or the waiver of a breach of any other term, condition or covenant.
42. **INVALID TERM:** If any provision of this Contract is declared or determined by any court of competent jurisdiction to be illegal, invalid or unenforceable, the legality, validity or enforceability of the remaining parts, terms and provisions shall not be affected thereby, and said illegal, unenforceable or invalid part, term or provision will be deemed not to be a part of this Contract.
43. **ENTIRE CONTRACT:** This Contract sets forth the entire Contract between the Parties hereto and fully supersedes any and all prior agreements, understanding, written or oral, between the Parties hereto pertaining to the subject matter thereof. This Contract may be modified only by a writing evidencing the Parties' mutual consent.

Certification Regarding Debarment, Suspension, Ineligibility and Voluntary Exclusion:

The District certifies to the best of its knowledge and belief, that it and its officials: Are not presently debarred, suspended, proposed for debarment, declared ineligible, or voluntarily excluded from covered transactions by any Federal department or agency according to Federal Acquisition Regulation Subpart 9.4. and by signing this contract, certifies that this vendor does not appear on the Excluded Parties List. <https://www.sam.gov/portal/public/SAM>

Susie Butler-Berkley
Contract Analyst

PREVAILING WAGE CERTIFICATION

I hereby certify that I will conform to the State of California Public Works Contract requirements regarding prevailing wages, benefits, on-site audits with 48-hours notice, payroll records, and apprentice and trainee employment requirements, for all Work on the above Project.

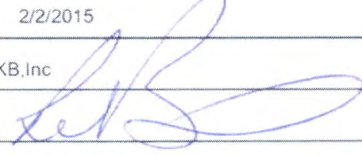
Date: 2/2/2015
Proper Name of Contractor: DKB, Inc
Signature: 
Print Name: R Dean Burows
Title: President

WORKERS' COMPENSATION CERTIFICATION

Labor Code section 3700 in relevant part provides:

Every employer except the State shall secure the payment of compensation in one or more of the following ways:

- a. By being insured against liability to pay compensation by one or more insurers duly authorized to write compensation insurance in this state.
- b. By securing from the Director of Industrial Relations a certificate of consent to self-insure, which may be given upon furnishing proof satisfactory to the Director of Industrial Relations of ability to self-insure and to pay any compensation that may become due to his employees.

I am aware of the provisions of section 3700 of the Labor Code which require every employer to be insured against liability for workers' compensation or to undertake self-insurance in accordance with the provisions of that code, and I will comply with such provisions before commencing the performance of the Work of this Contract.

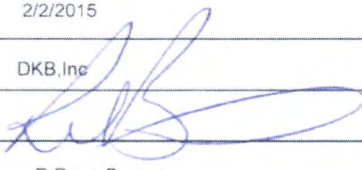
Date: 2/2/2015
Proper Name of Contractor: DKB, Inc
Signature: 
Print Name: R Dean Burows
Title: President

(In accordance with Article 5 - commencing at section 1860, chapter 1, part 7, division 2 of the Labor Code, the above certificate must be signed and filed with the awarding body prior to performing any Work under this Contract.)

Independent Maintenance Agreement - DKB, Inc. - Metwest Educational Center

CRIMINAL BACKGROUND INVESTIGATION CERTIFICATION

The undersigned does hereby certify to the governing board of the District as follows:

That I am a representative of the Contractor currently under contract ("Contract") with the District; that I am familiar with the facts herein certified, and am authorized and qualified to execute this certificate on behalf of Contractor. Contractor has taken at least one of the following actions with respect to the construction Project that is the subject of the Contract (check all that apply):

_____ Contractor has complied with the fingerprinting requirements of Education Code section 45125.1 with respect to all Contractor's employees and all of its subcontractors' employees who may have contact with District pupils in the course of providing services pursuant to the Contract, and the California Department of Justice has determined that none of those employees has been convicted of a felony, as that term is defined in Education Code section 45122.1. A complete and accurate list of Contractor's employees and of all of its subcontractors' employees who may come in contact with District pupils during the course and scope of the Contract is attached hereto; and/or

_____ Pursuant to Education Code section 45125.2, Contractor has installed or will install, prior to commencement of Work, a physical barrier at the Work Site, that will limit contact between Contractor's employees and District pupils at all times; and/or

Pursuant to Education Code section 45125.2, Contractor certifies that all employees will be under the continual supervision of, and monitored by, an employee of the Contractor who the California Department of Justice has ascertained has not been convicted of a violent or serious felony. The name and title of the employee who will be supervising Contractor's employees and its subcontractors' employees is

Name: R Dean Buopws 

Title: President

_____ The Work on the Contract is at an unoccupied school site and no employee and/or subcontractor or supplier of any tier of Contract shall come in contact with the District pupils.

Megan's Law (Sex Offenders). I have verified and will continue to verify that the employees of Contractor that will be on the Project site and the employees of the Subcontractor(s) that will be on the Project site are **not** listed on California's "Megan's Law" Website (<http://www.meganslaw.ca.gov/>).

Contractor's responsibility for background clearance extends to all of its employees, Subcontractors, and employees of Subcontractors coming into contact with District pupils regardless of whether they are designated as employees or acting as independent contractors of the Contractor.

Date: 2/2/15

Proper Name of Contractor: DKB, Inc.
Signature: 
Print Name: R Dean Burows
Title: President

CERTIFICATION REGARDING DEBARMENT, SUSPENSION, INELIGIBILITY AND VOLUNTARY EXCLUSION

I am aware of and hereby certify that neither DKB, Inc. [Type name of Contractor] nor its principals are presently debarred, suspended, proposed for debarment, declared ineligible, or voluntarily excluded from participation in this transaction by any Federal department or agency. I further agree that I will include this clause without modification in all lower tier transactions, solicitations, proposals, contracts and subcontracts.

Where the Contractor or any lower participant is unable to certify to this statement, it shall attach an explanation hereto.

IN WITNESS WHEREOF, this instrument has been duly executed by the Principal of the above named Contractor on the 2 day of February 2014 for the purposes of submission of this Agreement.

By:

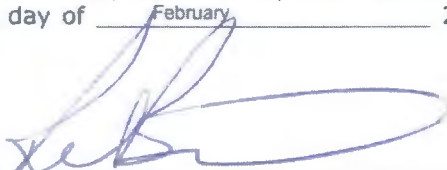
Signature
R Dean Burows
Typed or Printed Name
President
Title

DRUG-FREE WORKPLACE CERTIFICATION

PROJECT/CONTRACT NO.: _____ between Oakland Unified School District (the "District" or the "Owner") and DKB Inc. _____ (the "Contractor" or the "Bidder") (the "Contract" or the "Project").

This Drug-Free Workplace Certification form is required from the successful Bidder pursuant to Government Code sections 8350 et seq., the Drug-Free Workplace Act of 1990. The Drug-Free Workplace Act of 1990 requires that every person or organization awarded a contract or grant for the procurement of any property or service from any state agency must certify that it will provide a drug-free workplace by doing certain specified acts. In addition, the Act provides that each contract or grant awarded by a state agency may be subject to suspension of payments or termination of the contract or grant, and the contractor or grantee may be subject to debarment from future contracting, if the contracting agency determines that specified acts have occurred.

The District is not a "state agency" as defined in the applicable section(s) of the Government Code, but the District is a local agency and public school district under California law and requires all contractors on District projects to comply with the provisions and requirements of Government Code sections 8350 et seq., the Drug-Free Workplace Act of 1990.

Contractor shall certify that it will provide a drug-free workplace by doing all of the following:

1. Publishing a statement notifying employees that the unlawful manufacture, distribution, dispensation, possession, or use of a controlled substance is prohibited in the person's or organization's workplace and specifying actions which will be taken against employees for violations of the prohibition;
2. Establishing a drug-free awareness program to inform employees about all of the following:
 - a. The dangers of drug abuse in the workplace.
 - b. The person's or organization's policy of maintaining a drug-free workplace.
 - c. The availability of drug counseling, rehabilitation, and employee-assistance programs.
 - d. The penalties that may be imposed upon employees for drug abuse violations.
3. Requiring that each employee engaged in the performance of the contract or grant be given a copy of the statement required above, and that, as a condition of employment on the contract or grant, the employee agrees to abide by the terms of the statement.

I, the undersigned, agree to fulfill the terms and requirements of Government Code section 8355 listed above and will publish a statement notifying employees concerning (a) the prohibition of controlled substance at the workplace, (b) establishing a drug-free awareness program, and (c) requiring that each employee engaged in the performance of the contract be given a copy of the statement required by section 8355(a), and requiring that the employee agree to abide by the terms of that statement.

I also understand that if the District determines that I have either (a) made a false certification herein, or (b) violated this certification by failing to carry out the requirements of section 8355, that the Contract awarded herein is subject to termination, suspension of payments, or both. I further understand that, should I violate the terms of the Drug-Free Workplace Act of 1990, I may be subject to debarment in accordance with the requirements of section 8350 et seq.

I acknowledge that I am aware of the provisions of Government Code sections 8350 et seq. and hereby certify that I will adhere to the requirements of the Drug-Free Workplace Act of 1990

Date: 2/2/15

Proper Name of Contractor: DKB, Inc

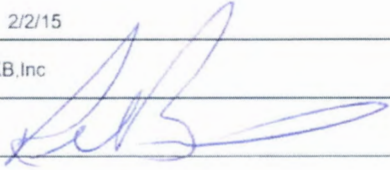
Signature: 

Print Name: r Dear Burows

Title: President

END OF DOCUMENT

ASBESTOS & OTHER HAZARDOUS MATERIALS CERTIFICATION

Contractor hereby certifies that no Asbestos, or Asbestos-Containing Materials, polychlorinated biphenyl (PCB), or any material listed by the federal or state Environmental Protection Agency or federal or state health agencies as a hazardous material, or any other material defined as being hazardous under federal or state laws, rules, or regulations "New Material Hazardous", shall be furnished, installed, or incorporated in any way into the Project or in any tools, devices, clothing, or equipment used to affect any portion of Contractor's work on the Project for District.

Contractor further certifies that it has instructed its employees with respect to the above-mentioned standards, hazards, risks, and liabilities.

Asbestos and/or asbestos-containing material shall be defined as all items containing but not limited to chrysotile, crocidolite, amosite, anthophyllite, tremolite, and actinolite. Any or all material containing greater than one-tenth of one percent (.1%) asbestos shall be defined as asbestos-containing material.

Any disputes involving the question of whether or not material is New Hazardous Material shall be settled by electron microscopy or other appropriate and recognized testing procedure, at the District's determination. The costs of any such tests shall be paid by Contractor if the material is found to be New Hazardous Material.

All Work or materials found to be New Hazardous Material or Work or material installed with "New Hazardous Material" containing equipment will be immediately rejected and this Work will be removed at Contractor's expense at no additional cost to the District.

Contractor has read and understood the document Hazardous Materials Procedures & Requirements, and shall comply with all the provisions outlined therein.

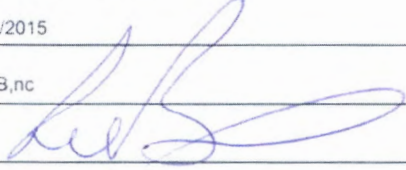
Date: 2/15/2015
Proper Name of Contractor: DKB, Inc
Signature: 
Print Name: R Dean Burows
Title: President

LEAD-PRODUCT(S) CERTIFICATION

California Occupational Safety and Health Administration (CalOSHA), Environmental Protection Agency (EPA), California Department of Health Services (DHS), California Department of Education (CDE), and the Consumer Product Safety Commission (CPSC) regulate lead-containing paint and lead products.

Because the Contractor and its employees will be providing services for the District, and because the Contractor's work may disturb lead-containing building materials, **CONTRACTOR IS HEREBY NOTIFIED** of the potential presence of lead-containing materials located within certain buildings utilized by the District. All school buildings built prior to 1993 are presumed to contain some lead-based paint until sampling proves otherwise.

The CDE mandates that school districts utilize DHS lead-certified personnel when a lead-based hazard is identified. Examples of lead-certified personnel include: project designers, inspectors, and abatement workers. Furthermore, since it is assumed by the district that all painted surfaces (interior as well as exterior) within the District contain some level of lead, it is imperative that the Contractor, its workers and subcontractors fully and adequately comply with all applicable laws, rules and regulations governing lead-based materials **(Including Title 8, California Code of Regulations, Section 1532.1)**. Any and all Work which may result in the disturbance of lead-containing building materials must be coordinated through the District.

The California Education Code also prohibits the use or import of lead-containing paint, lead plumbing and solders, or other potential sources of lead contamination in the construction of any new school facility or in the modernization or renovation of any existing school facility. The Contractor shall provide the District with any sample results prior to beginning Work, during the Work, and after the completion of the Work. The District may request to examine, prior to the commencement of the Work, the lead training records of each employee of the Contractor.

If failure to comply with these laws, rules, and regulations results in a site or worker contamination, the Contractor will be held solely responsible for all costs involved in any required corrective actions, and shall defend, indemnify and hold harmless the District, pursuant to the indemnification provisions of the Contract, for all damages and other claims arising therefrom. If lead disturbance is anticipated in the Work, only persons with appropriate accreditation, registrations, licenses and training shall conduct this Work.

It shall be the responsibility of the Contractor to properly dispose of any and all waste products, including but not limited to, paint chips, any collected residue, or any other visual material that may occur from the prepping of any painted surface. It will be the responsibility of the Contractor to provide the proper disposal of any hazardous waste by a certified hazardous waste hauler. This company shall be registered with the Department of Transportation (DOT) and shall be able to issue a current manifest number upon transporting any hazardous material from any school site within the District.

THE UNDERSIGNED HEREBY ACKNOWLEDGES, UNDER PENALTY OF PERJURY, THAT HE OR SHE HAS RECEIVED NOTIFICATION OF POTENTIAL LEAD-BASED MATERIALS ON THE OWNER'S PROPERTY, AS WELL AS THE EXISTENCE OF APPLICABLE LAWS, RULES AND REGULATIONS GOVERNING WORK WITH, AND DISPOSAL OF, SUCH MATERIALS WITH WHICH IT MUST COMPLY. THE UNDERSIGNED ALSO WARRANTS THAT HE OR SHE HAS THE AUTHORITY TO SIGN ON BEHALF OF AND BIND THE CONTRACTOR.

Independent Maintenance Agreement – DKB, Inc. – Metwest Educational Center

Date:

2/2/15

Proper Name of Contractor:

DKB, Inc

Signature:

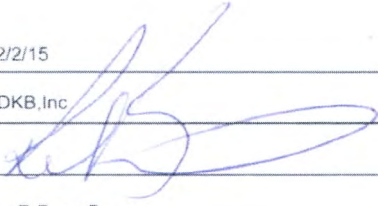

Print Name:

R Dean Burows

Title:

President

EXHIBIT "A" ("SCOPE OF WORK")

EXHIBIT A



PROPOSAL October 30, 2014

We propose to furnish materials and labor required to install thermal insulation on designated mechanical systems for "La Escuilta HS - Phase 1 - ASI #64". The 3M application is based on pictures and drawings provided by Kevin Newlon. If actual site conditions are not acceptable this proposal shall be deemed void until such time as a revised proposal is excepted. If no revised proposal is excepted the entire proposal will be deemed void and the owner will have every right to pursue alternative means.

Proposal Costs

Grease Duct	\$	8,988.00
Total:	\$	8,988.00

Exclusions: Bonding; Pipe shields, supports and saddles; under-ground, under-slab, below-floor and below-grade piping and ducting; VIC fittings; painting and labeling; handi-cap drains; heat tape; heat tracing; abatement; fire and wall penetrations; duct lining; lined duct; exhaust ducts; outside air; register boxes; and existing (except tie-ins).

Terms of Proposal

- 1 DKB, Inc, herein after designated as the Company, shall not be responsible for delays in making deliveries where occasioned by causes of any kind or extent beyond its control, including but not limited to embargoes; shortages of labor, raw materials, production facilities or transportation; labor difficulties; civil disorders of any kind; action of any civil authorities; fire, floods and accidents.
- 2 All work shall be performed during regular hours. Any work performed outside of these hours shall be charged for at overtime rates.
- 3 The customer agrees to provide adequate storage facilities for the materials delivered to the job and to furnish necessary light, water and power to complete the work.
- 4 All materials delivered by or on account of the Company and intended to be incorporated into the construction hereunder shall become the property of the owner as delivered; subject, however, to a lien in favor of the Company for any balance due on the purchase price thereof. In the event of non-payment of said purchase price or any portion thereof by purchaser due to insolvency or bankruptcy, the Company shall have the right under its said lien to retake any of such materials not then incorporated in the said construction.
- 5 ACCEPTANCE: This contract shall not be binding on the Company until it shall have been approved by an officer of the Company. Unless this quotation is accepted by you in writing within 30 days, it shall be considered withdrawn.
- 6 CLEAN UP: DKB, Inc will remove all rubbish and debris generated by our operations to your trash bins onsite and leave our work area in a clean condition (not broom cleaned). Our bid does not include and we are to be charged any prorated, general clean-up cost or haul off charges.
- 7 TERMS OF PAYMENT: Subject to prior credit approval, net cash for material delivered and labor expended during any on month, due and payable no later than the 10th of the following month. Balance of contract price due and payable upon completion of work. Interest at prevailing rates will be charged on all past due accounts. Any retention reduction given to contractor from owner shall be passed onto DKB, Inc. Retention shall be paid in full within 100 days of completion of insulation as related to this project.
- 8 Back Charges - DKB, Inc will not allow any back charges with out prior written consent from an officer of DKB, Inc.
- 9 Insurance, Liability and Bond - This bid does not include the cost of Builders Risk Insurance or the cost of a bond. DKB, Inc shall be only liable for acts of our own employees.
- 10 Acceptance of this bid is conditioned upon use of the AGC's or AIA Standard Subcontract Form.

ACCEPTED _____ 20 _____ DKB, Inc. DKBIN**020JG, CCB #137627, PWC-C-14840-AA-4,
MT CCR-162107, Utah 8159135-5551, CSLB# 987151

By _____

By *Eric Gibison*



Design Builder/Subcontractor: DKB Inc. Change Order Request No.: _____
 Project Name: La Escuilta HS - Phase 1 - ASI #64 Project No.: _____
 Work Activity: Mechanical Insulation

COST ITEM		COST (1)
ACTUAL COSTS	1. Straight Time Wages/Salaries -- Labor (48 hrs)	4,017.00
	2. Fringe Benefits and Payroll Taxes	832.00
	3. Overtime Wages/Salaries - Labor	0.00
	4. Fringe Benefits and Payroll Taxes -- Overtime	0.00
	5. Materials and Consumable items	3,055.00
	6. Sales Taxes: 8.75% of line 5	267.00
	7. Rental Charges	0.00
	8. Royalties	0.00
	9. Permits	0.00
	10. Total Direct Expense -- sum of lines 1-9	8,171.00
SUB-TOTAL	Sub-Sub (10% of line 10)	817.00
		TOTAL \$8,988.00

 (Design Builder's Company Name)

 (Signature) (3)

 (Title)

 (Date)

DKB Inc

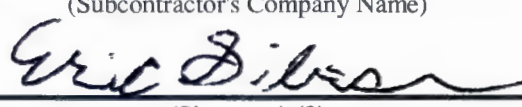
 (Subcontractor's Company Name)

 (Signature) (2)

Estimator

 (Title)

November 12, 2014

 (Date)

- Notes: (1) Round down all costs of 50¢ or less to the nearest dollar. Round up all costs of 51¢ or more to the nearest dollar.
 (2) This form shall be prepared and signed by Design Builder or Subcontractor actually performing the Work activity indicated above.
 (3) If this form is signed by a Subcontractor, it shall be reviewed and signed by Design Builder certifying the accuracy of the information.

PLANS

Architect's Supplemental Instruction - ASI # 64

To:	Kevin Newlon – McCarthy/Turner Group (MTG)	Date:	June 13, 2014
From:	Christopher Bradley - MVE Institutional Inc.	Client:	Oakland Unified School District (OUSD)
Project:	Downtown Educational Complex Phase 2	OUSD Job No.	07047-4
		MVEI Job No.	2009-40114
Subject:	Phase 1 Shaftwall Correction		

The Work shall be carried out in accordance with the following supplemental instructions, which is consistent with the intent of and reasonably inferable from the Contract Documents, or orders minor changes in the Work without change in the Contract Sum or Contract Time. If you believe that a change in Contract Sum or Contract Time is involved, submit written notice within twenty-one (21) days substantiating claim to the Architect. The claim must be made in accordance with the provisions of the Contract Documents. The Owner's authorization is required prior to proceeding to execute any work which will incur a change in Contract Sum or Contract Time.

Instruction:

Provide the shaftwall correction at the room adjacent to Phase 1 room A-246 per the attached DSA approved CCD 03.

Attach:

A110939 CCD 03

Distribution:

Kevin Newlon, MTG
Jeffrey Nall, MTG
Rocky Borton, OUSD
Saya Nhim, OUSD
Ken DeCarlo, KDI
Steve Hill, KDI
Bob Simons, MVEI
Anu Chaukkar, MVEI

End of ASI # 64

CB

J:\2009\0940114-OUSD DEC MetWest HS\Construction\1-Docs\08-Changes\ASI 64 – Phase 1 Shaftwall Correction

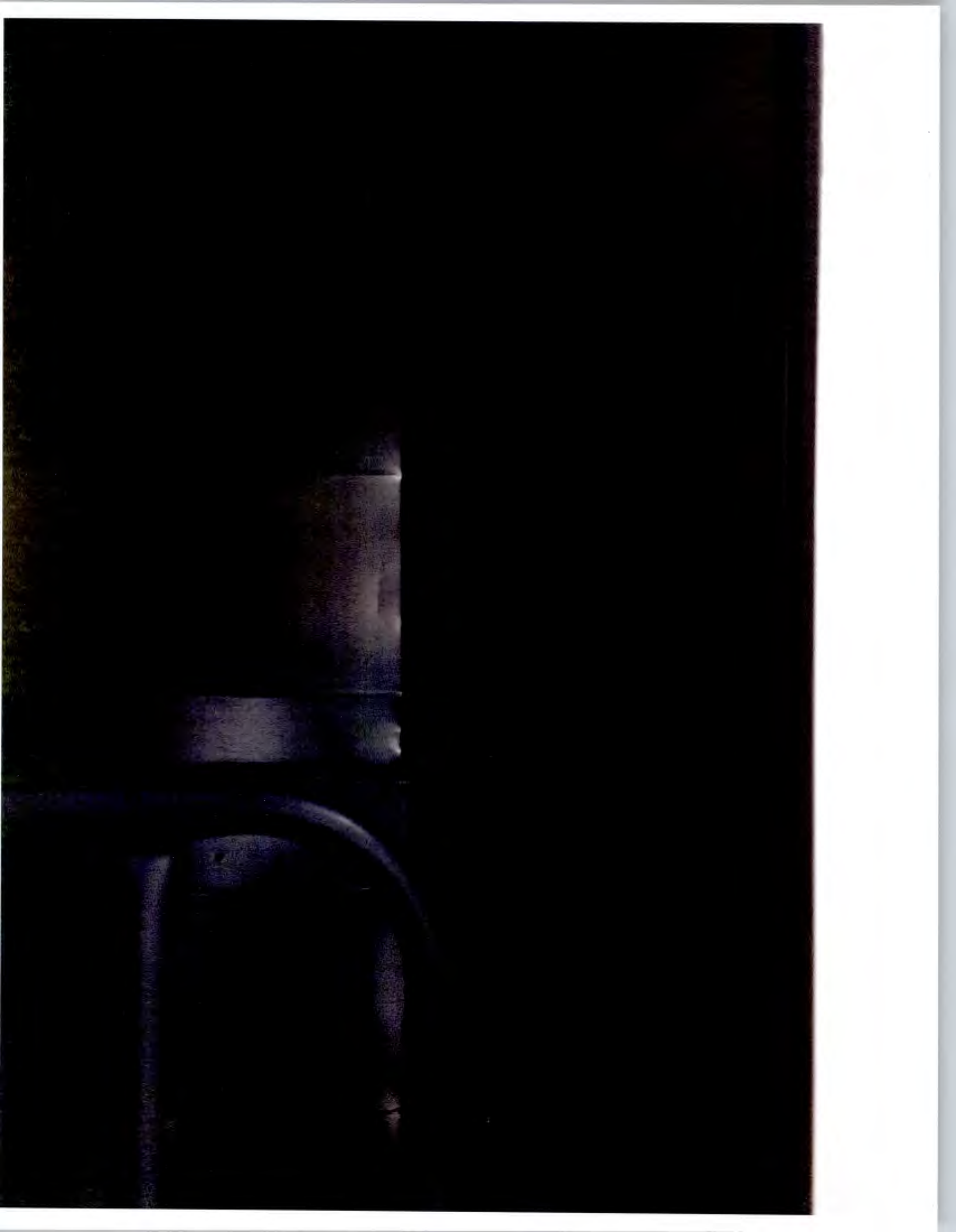





UNIVERSITY OF CALIFORNIA, BERKELEY
LIBRARY OF THE UNIVERSITY OF CALIFORNIA, BERKELEY
1000 UNIVERSITY AVENUE, BERKELEY, CALIF. 94720-1500
TEL: (415) 848-5000 FAX: (415) 848-5001
WWW: WWW.LIBRARY.UCB.EDU

UNIVERSITY OF CALIFORNIA, BERKELEY
LIBRARY OF THE UNIVERSITY OF CALIFORNIA, BERKELEY
1000 UNIVERSITY AVENUE, BERKELEY, CALIF. 94720-1500
TEL: (415) 848-5000 FAX: (415) 848-5001
WWW: WWW.LIBRARY.UCB.EDU

UNIVERSITY OF CALIFORNIA, BERKELEY
LIBRARY OF THE UNIVERSITY OF CALIFORNIA, BERKELEY
1000 UNIVERSITY AVENUE, BERKELEY, CALIF. 94720-1500
TEL: (415) 848-5000 FAX: (415) 848-5001
WWW: WWW.LIBRARY.UCB.EDU



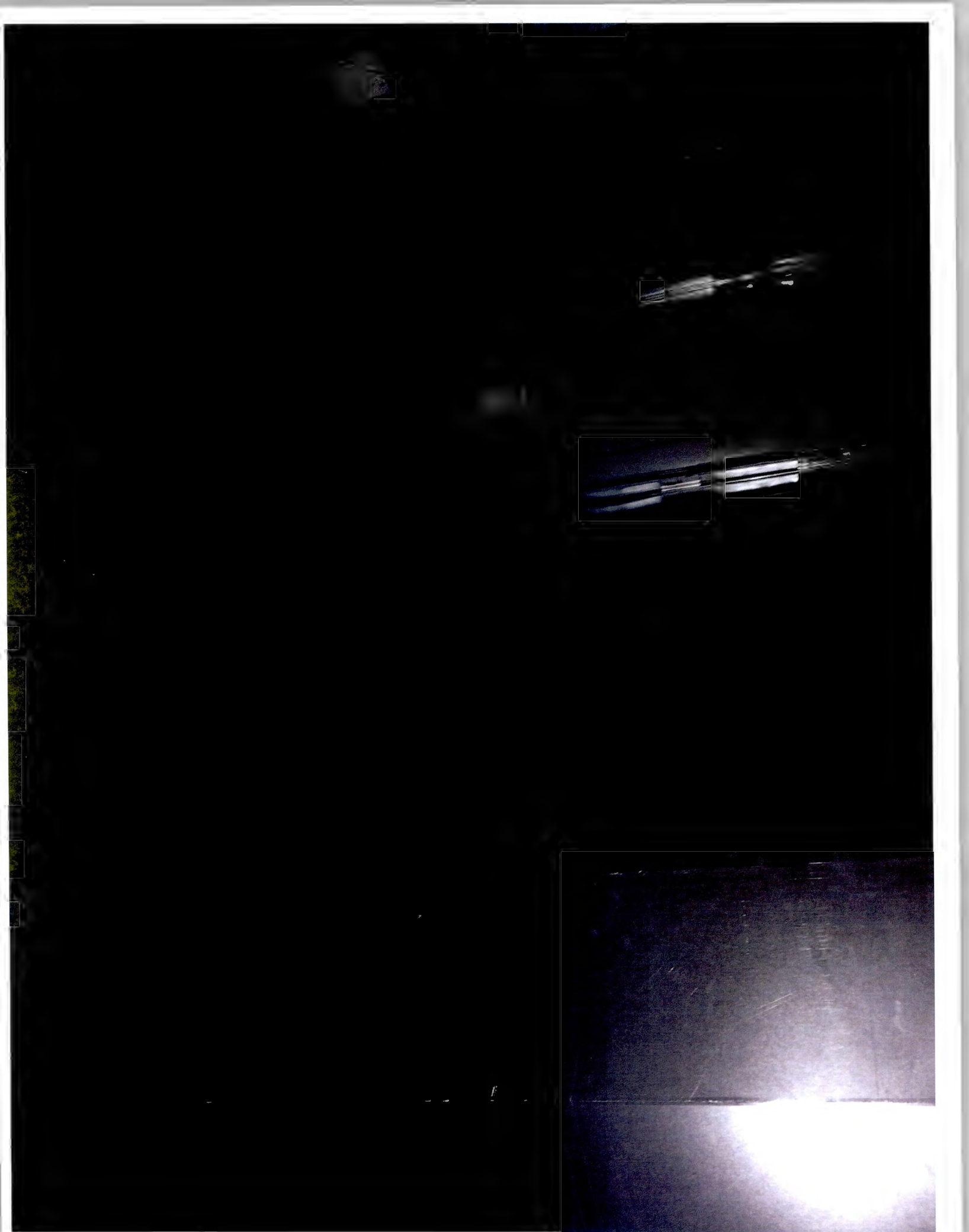





Addendum, Change Order,
 Drawing, Deferred Approval
 Worksheet and Transmittal Memo

New Resubmittal Date Sent: 10/22/13 File # 1-29 Appl. # 01-111447 FA

Downtown Education Complex Phase 2

Addendum Number	Deferred Submittal	Preliminary Change Order	Change Order Number	Other CCD 03
-----------------	--------------------	--------------------------	---------------------	-----------------

List of Material Received:	A. Master Copy 1	
	B. Copies 1	
	C. Tracing(s) each	of Sheets(s) Numbers(s)
	D. Prints(s) each	of Sheets(s) Numbers(s)
	E.	
	F.	

List of Material Approved:	<u>A</u>
----------------------------	----------

List of Material	To: <input checked="" type="checkbox"/> Architect <input type="checkbox"/> Structural Engineer		
	Name: MVE Institutional attn: Christopher Bradley		
<input type="checkbox"/> Sent	Address: 248 Third Street, Oakland, CA 94607	To	From

<input type="checkbox"/> Handed	Item	<u>A</u>	Co.	No. of Pages
<input type="checkbox"/> Faxed	Copies	<u>1</u>		Phone No.

Remaining Requirements: Corrections Required Change Order Required

- If Corrections are required, please submit the following:
- 1) Intact marked up check set.
 - 2) This transmittal memo.
 - 3) Two corrected copies of submittal.
 - 4) Calculations and other back-up information.
 - 5) Drawings bearing preliminary approval stamps to avoid re-review whenever possible.

OCT 22 2013

Remarks: Route: FLS -> SS last.

Notes for Clerical Use: Please make file copy of: _____ Other: _____
 Extend Plans and specs approval to cover:
 Only: Revised Plans and Specs.
 Additional: Plans and Specs. Scope increase: _____ Type of Approval: _____

Checked by	ACS <input checked="" type="checkbox"/> Not Required	FLS <input type="checkbox"/> Not Required <u>A. Chen</u>	SSS <input type="checkbox"/> Not Required <u>REAL ANYOUNG</u>
Approved by		<u>[Signature]</u>	<u>[Signature]</u>
Date		<u>10-28-13</u>	<u>11/20/2013</u>

Routed 10/29/2013



Division of the
State Architect

CALIFORNIA DEPARTMENT OF GENERAL SERVICES

FORM

DSA-140

Revised 11/12

CCD #: 3

DSA FILE #: 1 - 29

DSA APPL #: 01 - 110939

Date Oct 11, 2013

APPLICATION FOR APPROVAL OF

CONSTRUCTION CHANGE DOCUMENT - CCD CATEGORY A

Changes to or affecting the Structural Safety, Access Compliance or Fire & Life Safety Portions of the Project

Please Print or Type all Information - or fill out on-line and print for signatures

ALL FIELDS MUST BE COMPLETED See DSA IR A-6 for submittal requirements

1. Name of Project: Downtown Educational Complex Phase 1

2. Applicant Information:

Firm Name: MVE Institutional, Inc.

Contact Name: Christopher Bradley

Address: 3 MacArthur Place, Suite 850 SanLa Ana CA 92707

Phone Number: (949) 809-3380 e-mail: cbradley@mve-institutional.com

3. Name of Design Professional in General Responsible Charge: Robert Simons

4. Professional License Type Architect Structural Engineer License Number C-18301

5. Design Professional in General Responsible Charge Statement: The attached Construction Change Documents have been examined by me for design intent and appear to meet the appropriate requirements of Title 24, California Code of Regulations and the project specifications. They are acceptable for incorporation into the construction of the project.

Signature: _____

DESIGN PROFESSIONAL IN GENERAL RESPONSIBLE CHARGE

6. Brief Description of construction change (attach additional sheets if needed):

The Contractor did not install a one hour shaft wall adjacent to the Custodial/EMCS Office A-246. Due to the installed location of the two ducts, it is infeasible to correct the condition to match the DSA approved location of the shaft wall. Contractor is requesting to us a one-hour fire rated material (3M Fire Rated Duct Wrap) around the duct to achieve the one hour rating.

7. List of attachments:

- Sketch SK-CCD03
- 3M Fire Rated Duct Wrap Product Data
- DSA Approved Sheet A1-11.2.2 Reference Sheet

AC PA
 01-111447 DATE 11/20/13

8. List of DSA approved documents affected by this CCD:

Sheet A1-11.2.2

OCT 22 2013

9. NOTE: Check here to confirm that all CCD drawings and calculations have been stamped and signed by the responsible design professional.

9.5

MECHANICAL DUCT FROM ROOF TO SECOND FLOOR

MECHANICAL DUCT FROM ROOF TO FIRST FLOOR

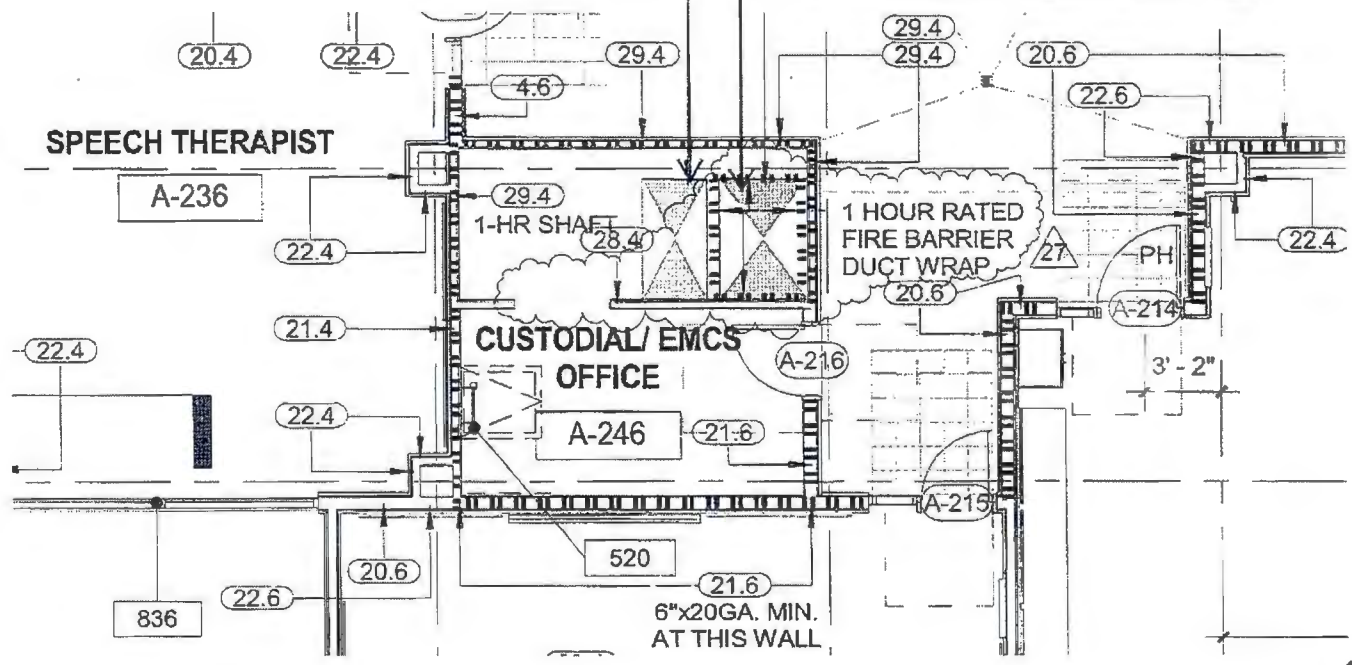

T

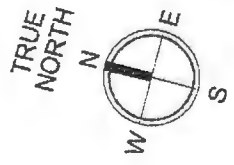

SK-CCD03
 NTS
 10/11/13
 REF. SHEET A1-11.2.2

APR 16 2014 11:47 AM
 AC
 WED/13

DM OF THE...
 ARCHITECT



Fire Barrier Duct Wrap 615+

Duct Wrap Fire Protection System for Commercial Kitchen Grease and Ventilation Air Ducts

Product Data



BATTS AND BLANKETS
FOR USE IN FIRE RESISTIVE DUCT ASSEMBLIES
SEE UL FIRE RESISTANCE DIRECTORY
8039

LISTED



DUCT INSULATION
90G9

LISTED



FIRESTOP SYSTEMS
SEE INTERTEK DIRECTORY

LISTED



FIRESTOP SYSTEMS
SEE INTERTEK DIRECTORY

1. Product Description

3M™ Fire Barrier Duct Wrap 615+ is a fire resistant wrap consisting of an inorganic fiber blanket encapsulated with a scrim-reinforced foil. The product is 1-1/2 in. thick, 6pcf density.¹ It is used to fire rate commercial kitchen grease ducts as well as ventilation ducts, and is a proven alternative to 1 or 2 hour fire resistant rated shaft enclosures. With its excellent insulating capabilities, low weight and thin profile, it is an ideal choice for a duct enclosure system. This non-asbestos wrap installs easily because of its high flexibility and strength.

Features

- Two-layer wrap for grease ducts rated as a shaft alternative per ASTM E 2336
- Zero clearance to combustible throughout the entire enclosure system for congested spaces
- One-layer wrap for fire-resistive ventilation ducts per ISO 6944
- High flexibility for installation ease
- Foil encapsulated for blanket protection, less dust, and high wrap strength
- Widest range of penetration seal systems

2. Applications

Two-layer applications of 3M™ Fire Barrier Duct Wrap 615+ meet the criteria of ASTM E 2336 'Standard Test Methods for Fire Resistive Grease Duct Enclosure Systems'.

3M™ Fire Barrier Duct Wrap 615+ as single-layer fire resistant wrap application has passed the ISO 6944 'Fire Resistance Tests – Ventilation Ducts'.

3M™ Fire Barrier Duct Wrap 615+ is an ideal fire resistive enclosure for commercial kitchen grease ducts and ventilation air ducts. It is a proven performance alternative to a 1 or 2 hour fire resistant rated shaft enclosures and provides zero clearance to combustible construction throughout the entire enclosure system. 3M™ Fire Barrier Water Tight Sealant 1000 NS, 3M™ Fire Barrier Water Tight Sealant 1003 SL or 3M™ Fire Barrier Water Tight Sealant 2000+ Silicone Sealants is used in combination with 3M™ Fire Barrier Duct Wrap 615+ to firestop the duct when the duct penetrates fire rated floors and walls.

3. Availability

Unit	Size	Quantity	Weight
Roll	24 in. x 25 ft. (60,9 mm x 635 cm)	1	45 lbs (20.4 kg)
Roll	48 in. x 25 ft. (121 cm x 635 cm)	1	90 lbs (40.8 kg)

4. Typical Physical Properties

Blanket Color	Weight
White	0.9 lbs./ft. ² (4.38 kg/m ²)

¹ In accordance with the tolerances in ASTM C 892 Standard Specification for High-Temperature Fiber Blanket Thermal Insulation.

5. Performance

A. 3M™ Fire Barrier Duct Wrap 615+ has been tested in accordance with the following:

ASTM E 2336	Standard Test Methods for Fire Resistive Grease Duct Enclosure Systems
ASTM E 119	Standard Test Methods for Fire Tests of Building Construction and Materials
ASTM E 814	Standard Test Method for Fire Tests of Through-Penetration Fire Stops
ASTM E 136	Standard Test Method for Behavior of Material in a Vertical Tube Furnace at 750°C (1382°F)
ASTM C 518	Standard Test Method for Steady-State Thermal Transmission Properties by Means of the Heat Flow Meter Apparatus
ASTM C 1338	Standard Test Method for Determining Fungi Resistance of Insulation Materials and Facings
ASTM E 84	Standard Test Method for Surface Burning Characteristics of Building Materials
ISO 6944-85	Fire Resistance Tests – Ventilation Ducts

B. Surface Burning Characteristics (ASTM E 84, ULC/CAN S-102)

	Flame Spread	Smoke Developed
Foil Encapsulated Blanket	<25	<50

F. Design Listings

Fire Resistive Rating	Enclosure System	Third-Party Testing Services Design Listing	Description
Grease Duct Listings – ASTM E 2336			
1 and 2 Hour	2 layers of 3M™ Fire Barrier Duct Wrap 615+, minimum 3 in. (76 mm) perimeter and longitudinal overlaps	Intertek 3MU/FRD 120-18	48 x 48 in. Rectangular
		Intertek 3MU/FRD 120-19	48 in. Round
Ventilation Duct Listings – ISO 6944			
1 and 2 Hour	1 layer of 3M™ Fire Barrier Duct Wrap 615+, minimum 3 in. (76 mm) perimeter and longitudinal overlaps	Intertek 3MU/FRD 120-15 Underwriters Laboratories HNLJ.V-27	24 x 85 in. Rectangular
		Intertek 3MU/FRD 120-04	40 in. Round

G. Codes and Standards

3M™ Fire Barrier Duct Wrap 615+ installed per ASTM E 2336 tested Design Listings meets the requirements of the following codes:

NFPA 96, 2008 Edition
2006/2009 International Mechanical Code

3M™ Fire Barrier Duct Wrap 615+ installed per ISO 6944 tested Design Listings can be utilized to meet the requirements of the following codes:

NFPA 92A Standard for Smoke-Control System Utilizing Barriers and Pressure Differences, 2006 Edition – Section 6.6.2
NFPA 92B Standard for Smoke Management Systems in Malls, Atria, and Large Spaces, 2005 Edition – Section 7.5.2
NFPA 101® Life Safety Code®, 2006 Edition – Section(s) 8.6.7, 18.7.7
International Mechanical Code®, 2006 Edition – Section 513.10.2
International Building Code®, 2006 Edition – Section 909.10.2

C. Thermal Conductivity

Temp.	$\frac{Btu - in.}{hr - ft^2 - ^\circ F}$	$\frac{W}{m^2 - K}$
500°F (260°C)	0.48	0.07
1000°F (537°C)	0.97	0.14
1500°F (815°C)	1.57	0.23
1800°F (982°C)	1.98	0.29
2000°F (1093°C)	2.23	0.33

D. Linear Shrinkage

24 Hr @ 2012°F (1000°C): 1.2%

E. R-Value

Single layer of 3M™ Fire Barrier Duct Wrap 615+ at 77°F (25°C):

$$6.38 \frac{^\circ F - ft^2 - hr}{Btu}$$

These are only partial lists for design listings and code requirements. For the latest code and approval information go to www.3M.com/firestop or speak to your authorized 3M distributor or sales representative at (800) 328-1687.

6. Installation Techniques

3M™ Fire Barrier Duct Wrap 615+ should be installed per the application design listing in accordance with the following basic installation instructions.

A. Material and Equipment

- 3M™ Fire Barrier Duct Wrap 615+ blanket, 1-1/2 in. (38 mm) thick², 24 in. (60 cm) or 48 in. (121 cm) wide, 25 ft. (635 cm) standard length. The 48 in. (121 cm) wide blanket helps to minimize waste.
- Aluminum foil tape.
- Minimum 3/4 in. (19 mm) wide filament tape.
- Stainless steel banding material, minimum 1/2 in. (12,7 mm) wide, minimum 0.015 in. (0,38 mm) thick, with stainless steel banding clips.
- Hand banding tensioner, crimping tool and banding cutter.
- Minimum 12 gauge copper-coated steel insulation pins used with minimum 2-1/2 in. (38 mm) square galvanized steel or stainless steel clips or 1-1/2 in. (38 mm) dia. round or equivalent sized insulated cup-head pins.
- Capacitor discharge stud gun.
- Access door hardware: four galvanized steel thread rods, 1/4 in. (6 mm) diameter by minimum 6 in. long (152 mm) with 1/4 in. (6 mm) wing nuts and 1/4 in. (6 mm) washers.
- 4 in. (102 mm) long steel hollow tubing to fit threaded rods.
- Minimum 4 pcf (64 kg/m³) density mineral wool or scrap pieces of 3M™ Fire Barrier Duct Wrap 615+.
- 3M™ Fire Barrier Water Tight Sealant 1000 NS, 1003 SL or 3M™ Fire Barrier Silicone Sealant 2000+.

B. Storage

The 3M™ Fire Barrier Duct Wrap 615+ and 3M™ Fire Barrier Water Tight Sealant 1000 NS, 1003 SL or 3M™ Fire Barrier Silicone Sealant 2000+ must be stored in a dry warehouse environment. Pallets should not be stacked.

C. Preparatory Work

3M™ Fire Barrier Duct Wrap 615+ is installed with common tools, such as knives, banders and capacitor discharge guns for applying insulation pins. In order to install the duct firestop system, the surfaces of all the openings and penetrating items need to be clean, dry, frost free and free of dust.

D. Method (Two-Layer for ASTM E 2336)

Note: These general instructions for installing 3M™ Fire Barrier Duct Wrap 615+ include a two-layer wrap construction of 24-inch 3M™ Fire Barrier Duct Wrap 615+ blanket applied directly to a grease duct. To minimize waste, 3M™ Fire Barrier Duct Wrap 615+ material should be rolled out tautly before measuring. The first layer of 3M™ Fire Barrier Duct Wrap 615+ blanket is wrapped around the perimeter of the duct and is cut to a length to overlap itself not less than 3 in. (76 mm). The overlap made by adjacent blankets forms the "longitudinal" overlap. Aluminum foil tape is used to seal all cut edges of the blanket and any tears in the foil scrim. This first layer is temporarily held in place using filament tape. The first layer does not require stainless steel banding.

The second layer of 3M™ Fire Barrier Duct Wrap 615+ blanket is wrapped around the perimeter of the previously installed first layer of 615+, and is cut to a length to overlap itself not less than 3 in. (76 mm). The centerline of the second layer of blanket should be centered over the overlap of the first layer. The second layer of blanket requires longitudinal overlap onto adjacent blankets of not less than 3 in. (76 mm). The second layer of blanket is also held in place using filament tape. The second layer of wrap requires permanent fastening with stainless steel banding or rows of weld pins (impaling or cup-head style).

² In accordance with the tolerances in ASTM C 892 Standard Specification for High-Temperature Fiber Blanket Thermal Insulation.

Figure 1

**3M™ Fire Barrier Duct Wrap 615+ Commercial Kitchen Grease Duct Systems
1 or 2 Hour Shaft Alternative Zero Clearance to Combustibles
Telescoping Wrap Technique With Banding For Ducts 24 inches (60,9 cm) or Less**

1. First Layer 3M™ Fire Barrier Duct Wrap 615+
2. Second Layer 3M™ Fire Barrier Duct Wrap 615+
3. 3/4 in. (19 mm) Wide Filament Tape
4. Steel Banding 1/2 in. (13 mm) Wide Min. Typical for Permanent Fastening
5. 3 in. (76 mm) Min. Longitudinal Overlap
6. 3 in. (76 mm) Min. Perimeter Overlap

System integrity is limited by quality of installation.

Ducts > 24 in. (60,9 cm) Wide Require Pinning on the Bottom Side.

Consult Current Independent Testing Laboratories (Intertek, UL) For Design or System Details.

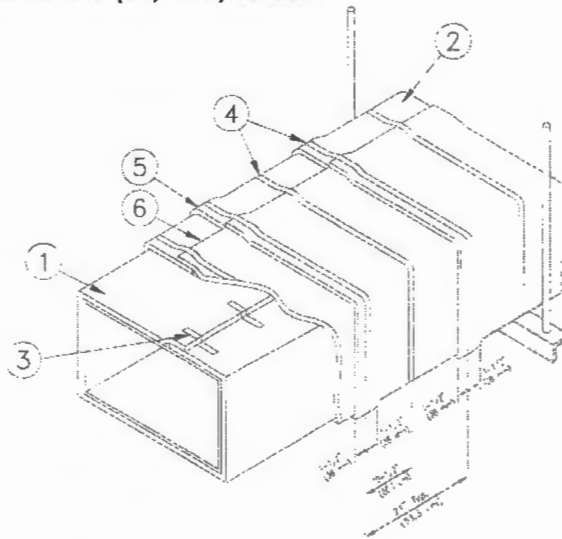

There are three (3) approved installation techniques for installing the 3M™ Fire Barrier Duct Wrap 615+ (See Figures 1A, 1B, & 1C):

**1. Telescoping 3 in. (76 mm) Overlap Wrap
Cross Section View**

With the telescoping overlap wrap method, each blanket overlaps one adjacent blanket, and each blanket has one edge exposed and one edge covered by the next blanket as shown in Figure 1A. The visible edges of the perimeter overlaps all point in the same direction.

1. One Layer 3M™ Fire Barrier Duct Wrap 615+
2. Steel Banding 1/2 in. (13 mm) Wide Min. Typical
3. 3 in. (76 mm) Min. Longitudinal Overlap

Figure 1A

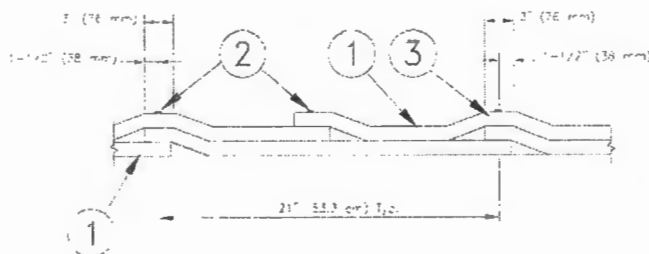

**2. Checkerboard 3 in. (76 mm) Overlap Wrap
Cross Section View**

With the 3 in. (76 mm) checkerboard overlap wrap method, blankets with both edges exposed alternate with blankets with covered edges, as shown in Figure 1B. The visible edges of the perimeter overlaps alternate their directions and appear on every other blanket.

1. One Layer 3M™ Fire Barrier Duct Wrap 615+
2. Steel Banding 1/2 in. (13 mm) Wide Min. Typical
3. 3 in. (76 mm) Min. Longitudinal Overlap

Figure 1B

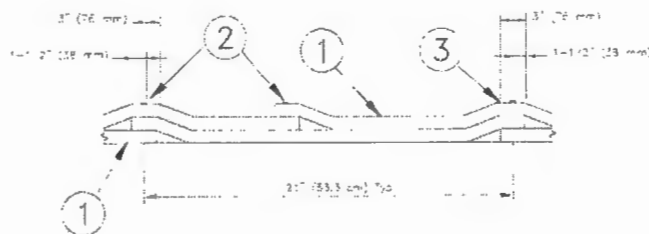
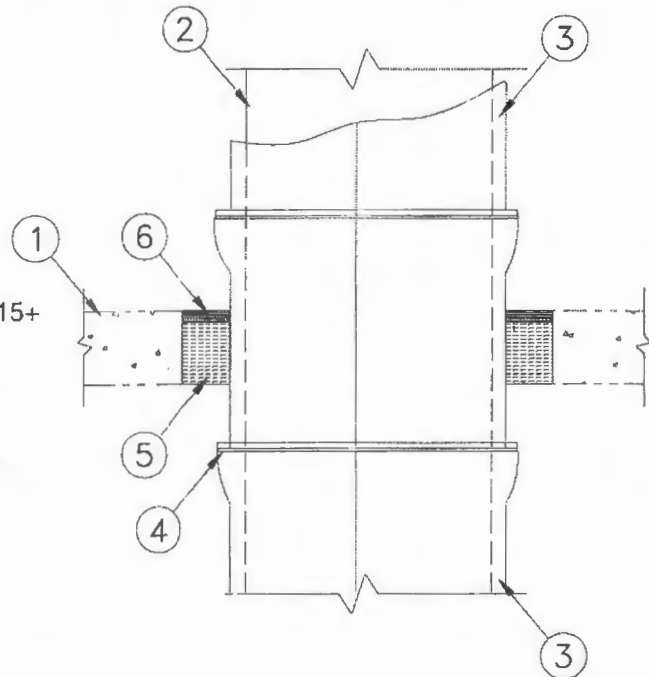

Figure 3

**3M™ Fire Barrier Duct Wrap 615+
Commercial Kitchen Grease Duct Systems
1 or 2 Hour Through Penetration Systems
4-1/2 inch (11,4 cm) Concrete Floor or Wall**

1. Floor/Ceiling or Wall Assembly
2. Duct
3. One or Two Layers 3M™ Fire Barrier Duct Wrap 615+
4. Banding or Pinning
5. Packing Material
6. 3M™ Fire Barrier Water Tight Sealant 1000 NS,
3M™ Fire Barrier Water Tight Sealant 1003 SL, or
3M™ Fire Barrier Silicon Sealant 2000+. For Wall
Assembly Apply Sealant To Both Sides of Wall.
3M™ Fire Barrier Water Tight Sealant 1003 SL
Not Suited For Wall Applications.



System integrity is limited by quality of installation.

Consult Current Independent Testing Laboratories (Intertek, UL) For Design or System Details.

Penetrations

When the duct penetrates a fire rated wall, ceiling or floor, an approved firestop system must be employed. Figure 3 illustrates a typical condition. To firestop the wrapped duct, follow the installation parameters detailed in a compatible ASTM E 814 tested through-penetration firestop design. **Note:** Through-penetration designs in which the duct is bare where it passes through combustible or limited-combustible construction (e.g. gypsum walls or wood joist floor-ceiling assemblies) are appropriate for ventilation duct scenarios only. It is not appropriate for bare, uninsulated grease ducts to pass through combustible assemblies.

Through Penetration Systems ASTM E 814		Intertek Testing Services			
Sealants	Fire Resistive Rating	Design Listing	(former OPL name)	Description	Firestopped To
3M™ Fire Barrier Water Tight Sealant 1000 NS	1 Hour	3MU/PH 60-01	FS 557 W	Gypsum Wall	Duct Wrap
		3MU/PV 60-01	FS 558 F	Floor-Ceiling	Duct Wrap
3M™ Fire Barrier Water Tight Sealant 1003 SL	2 Hour	3MU/PH 120-14	FS 559 W	Gypsum Wall	Duct Wrap
		3MU/PH 120-16	FS 563 W	Concrete Wall	Bare Duct
		3MU/PH 120-17	FS 566 W	Gypsum Shaft Wall	Bare Duct
		3MU/PH 120-18	FS 568 W	Gypsum Wall	Bare Duct
3M™ Fire Barrier Silicone Sealant 2000+	2 Hour	3MU/PH 120-29	FS 579 W	Concrete Wall	Duct Wrap
		3MU/PV 120-06	FS 576 F	Concrete Floor	Bare Duct
		3MU/PV 120-07	FS 578 F	Concrete Floor	Duct Wrap

For technical data and properties of 3M™ Fire Barrier Water Tight Sealant 1000 NS, 3M™ Fire Barrier Water Tight Sealant 1003 SL or 3M™ Fire Barrier Silicone Sealant 2000+, see separate product data sheets available from your 3M representative or go to www.3M.com/firestop.

This is only a partial list of design listings. For the latest information go to www.3M.com/firestop or speak to your authorized 3M distributor or sales representative at (800) 328-1687.

7. Maintenance

No maintenance is required when installed in accordance with the 3M Installation Instructions. Once installed, if any section of the 3M™ Fire Barrier Duct Wrap 615+ is damaged so that the blanket requires repair, the following procedures apply:

- The damaged section should be removed by cutting the steel banding or removing the clips holding it in place.
- A new section of the same dimension should be cut from a roll of 3M™ Fire Barrier Duct Wrap 615+, either 24 in. (60,9 cm) or 48 in. (121 cm) wide.
- The new section should be placed and fitted ensuring the same overlap that existed previously.
- The steel banding should be placed around the material and tensioned so as to sufficiently hold the 3M™ Fire Barrier Duct Wrap 615+ in place.
- If the blanket has not been damaged but the foil has ripped, seal the rips with aluminum foil tape.

8. Purchase Information

3M Fire Barrier products are available through a network of nationwide distributors. For information on where to buy, go to www.3M.com/firestop.

9. Safe Handling Information

Consult Material Safety Data Sheet prior to handling and disposing of 3M™ Fire Barrier Duct Wrap 615+.

Important Notice to User:

Product Use: Many factors beyond 3M's control and uniquely within user's knowledge and control can affect the use and performance of a 3M product in a particular application. Given the variety of factors that can affect the use and performance of a 3M product, user is solely responsible for evaluating the 3M product and determining whether it is fit for a particular purpose and suitable for user's method of application.

Warranty and Limited Remedy: 3M warrants that each 3M Fire Protection Product will be free from defects in material and manufacture for 90 days from the date of purchase from 3M's authorized distributor. 3M MAKES NO OTHER EXPRESS OR IMPLIED WARRANTIES, INCLUDING ANY IMPLIED WARRANTY OF MERCHANTABILITY OR FITNESS FOR A PARTICULAR PURPOSE. If a 3M product does not conform to this warranty, the sole and exclusive remedy is, at 3M's option, replacement of the 3M product or refund of the purchase price.

Limitation of Liability: Except where prohibited by law, 3M will not be liable for any loss or damage arising from the 3M product, whether direct, indirect, special, incidental or consequential, regardless of the legal theory asserted.



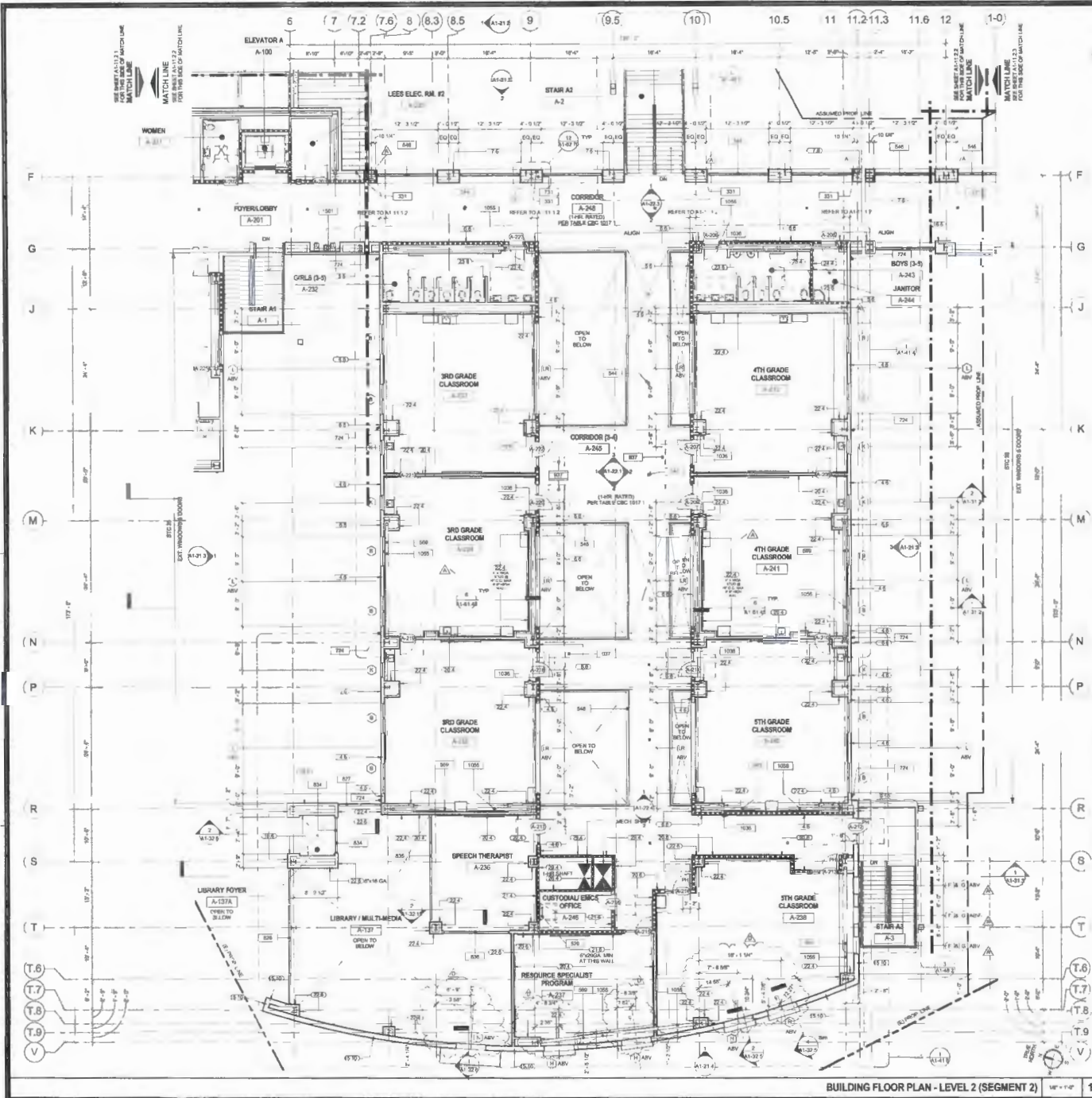

BUILDING FLOOR PLAN - LEVEL 2 (SEGMENT 2) 1/8" = 1'-0" 1

Key Value	DESCRIPTION
301	ROOF DRAIN AND FL FANOUT FROM GUTTER AT WA WALL SYSTEM PER DETAIL 10A-11.1
302	ROOF ACCESS LADDER REFER TO DETAIL 10A-12.2
303	FLOOR DRAIN FOR LOCATION REFER TO DETAIL 10A-12.3
304	PLUMBING REFER TO DETAIL 10A-12.4
305	1/2" MIN. HIGH PAINTED GALVANIZED METAL GUARDRAILS WITH METAL CAPS
306	1/2" MIN. HIGH PAINTED STRUCTURAL STEEL BRACKETS REFER TO SPEC'S FOR SIZES AND LOCATIONS REFER TO STRUCTURAL DRAWING
307	PAINTED GALVANIZED SHIRT METAL GUTTERS, DOWNSPOUT CONNECTIONS TO STORM DRAIN WITH MECHANICAL FITTER REFER TO CIVIL AND PLUMBING DRAWING FOR LOCATION
308	PAINTED GALVANIZED SHEET METAL GUTTER CONNECTED TO DOWNSPOUT
309	CURTAIN WALL SYSTEMS REFER TO DETAIL 10A-13.1
310	CURTAIN WALL SYSTEM #1 REFER TO DETAIL 10A-13.2
311	CURTAIN WALL SYSTEM #2 REFER TO DETAIL 10A-13.3
312	CURTAIN WALL SYSTEM #3 REFER TO DETAIL 10A-13.4
313	1/2" IF RECYCLED RUBBER WALK-OFF MATS REFER TO SPECIFICATION
314	NEW RECYCLED FIVE EXTENDER CABINET 2" WALL PROTRUSION IF 20" FROM CABINET BETWEEN 2" TO 4" REFER TO SPEC FOR FINISH & DETAIL 10A-14.4
315	WHERE HEAD ROOM CLEARANCE AT UNDERSIDE OF STRUCTURAL BRACE IS BE TYPED 7' TO 8' ABOVE FINISH FLOOR PROVIDE CANE RESTRICTION WARNING (SEE FIGURE 118.7A) REFER TO IBC, TABLE 101.4.1
316	ACCESSIBLE REAR AND LOW OVERHANG FLOOR AREA REFER TO SPEC'S AND DETAIL 10A-14.5 FOR FINISHING

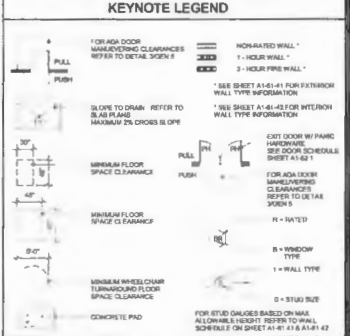

- PLAN LEGEND**
- REFER TO SHEETS A1-01.1 & A1-02.3 FOR EXISTING PLANS
 - REFER TO SHEETS A1-02.3 & A1-02.4 FOR ACCESSIBILITY SIGNAGE PLANS AND DEN'S & CORN FOR PROJECT COMPLIANCE (SIGNAGE DETAILS) REFER TO DEN'S FOR ADDITIONAL ACCESSIBILITY REQUIREMENTS
 - REFER TO SHEET GEN-4 FOR ADDITIONAL ACCESSIBILITY REQUIREMENTS
 - REFER TO DETAIL PLAN SHEETS A1-14.1 THRU A1-14.2.3 FOR EXISTING LOCATIONS
 - ALL DIMENSIONS SHOWN ARE TO FACE OF STUD UNLESS NOTED OTHERWISE, CENTER OF WINDOW/DOOR IS USED
 - REFER TO DOOR SCHEDULES SHEETS A1-02.1 AND A1-02.2, AND WINDOW SCHEDULES A1-03.1 FOR SIZES AND RATINGS OF DOORS AND WINDOWS
 - ALL DOORS TO BE 4" FROM PERPENDICULAR WALL AT FINISH BISE UNLESS NOTED OTHERWISE
 - REFER TO SHEET A-61.11 FOR FIRE RATED WALL PENETRATION DETAILS
 - INSTALL HORIZONTAL BLINDS AT ALL WINDOWS AND CURTAIN WALLS IN ALL ROOMS EXCEPT AT THE GREAT ROOM AND LIBRARY PER SPEC'S
 - INSTALL ROLLER SHADERS AT ALL WINDOWS AND CURTAIN WALLS WITHIN THE GREAT ROOM AND LIBRARY PER SPEC'S
 - REFER TO 1/4" SCALE PLAN FOR INTERIOR DIMENSIONS AND FURNITURE LAYOUT
 - REFER TO SHEETS A1-02.4 AND A1-03.3 FOR CURTAIN WALL SYSTEM TYPES & SIZES
 - REFER TO EXTERIOR & INTERIOR ELEVATIONS FOR THE LOCATION OF DAY LENDING AND VISION WINDOWS
 - REFER TO SLAB PLAN SHEETS A1-12.1 THRU A1-12.3 FOR SLAB LAYOUT AND DEPRESSIONS
 - REFER TO STRUCTURAL SHEET E1-1.3.3.1.2 FOR CONNECTION DETAILS & ETC
 - REFER TO SHEET A1-61.41 FOR EXTERIOR WALL ASSEMBLIES AND SHEET A1-61.47 FOR INTERIOR WALL ASSEMBLIES

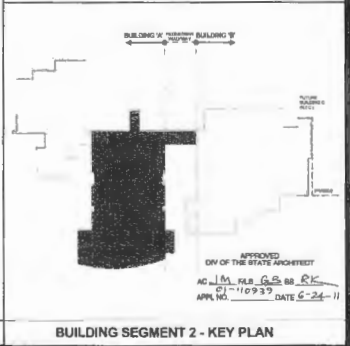

DOWNTOWN EDUCATIONAL COMPLEX
OAKLAND, CALIFORNIA

OAKLAND UNIFIED SCHOOL DISTRICT
PROJECT NO. 07047

IDENTIFICATION STAMP
DIVISION OF THE STATE ARCHITECT
OFFICE OF REGULATION SERVICES
A# 01-110939
AC PLS SS
DATE

REVISIONS	DESCRIPTION	DATE
1	ADDENDUM TO	10/27/10
2	ADDENDUM TO	11/09/10

SHEET TITLE
BUILDING FLOOR PLAN - LEVEL 2 SEGMENT 2
PHASE 1, INCREMENT 2

SHEET NUMBER
A1-11.2.2

MVE Institutional
Planning Architecture Interiors

MVE Institutional Inc.
350 Frank H. Ogden Plaza, Suite 201
Oakland, CA 94612
Tel: 510.267.3180 Fax: 510.267.3181
www.mve-institutional.com

**CERTIFICATE OF LIABILITY INSURANCE**DATE (MM/DD/YYYY)
2/3/2015

THIS CERTIFICATE IS ISSUED AS A MATTER OF INFORMATION ONLY AND CONFERS NO RIGHTS UPON THE CERTIFICATE HOLDER. THIS CERTIFICATE DOES NOT AFFIRMATIVELY OR NEGATIVELY AMEND, EXTEND OR ALTER THE COVERAGE AFFORDED BY THE POLICIES BELOW. THIS CERTIFICATE OF INSURANCE DOES NOT CONSTITUTE A CONTRACT BETWEEN THE ISSUING INSURER(S), AUTHORIZED REPRESENTATIVE OR PRODUCER, AND THE CERTIFICATE HOLDER.

IMPORTANT: If the certificate holder is an **ADDITIONAL INSURED**, the policy(ies) must be endorsed. If **SUBROGATION IS WAIVED**, subject to the terms and conditions of the policy, certain policies may require an endorsement. A statement on this certificate does not confer rights to the certificate holder in lieu of such endorsement(s).

PRODUCER Commercial Lines - (509) 358-3800 Wells Fargo Insurance Services USA, Inc. - CA Lic#: 0D08408 601 West Main Street, Suite 1400 Spokane, WA 99201-0635	CONTACT NAME: Dianne Johnson PHONE (A/C, No, Ext): 509-358-3970 FAX (A/C, No): 866-510-9588 E-MAIL ADDRESS: dianne.johnson@wellsfargo.com																				
	<table border="1"> <thead> <tr> <th colspan="2">INSURER(S) AFFORDING COVERAGE</th> <th>NAIC #</th> </tr> </thead> <tbody> <tr> <td>INSURER A:</td> <td>American Zurich Insurance Company</td> <td>40142</td> </tr> <tr> <td>INSURER B:</td> <td>Zurich American Insurance Co</td> <td>16535</td> </tr> <tr> <td>INSURER C:</td> <td>National Union Fire Ins. Co. of Pittsburgh, PA</td> <td>19445</td> </tr> <tr> <td>INSURER D:</td> <td></td> <td></td> </tr> <tr> <td>INSURER E:</td> <td></td> <td></td> </tr> <tr> <td>INSURER F:</td> <td></td> <td></td> </tr> </tbody> </table>	INSURER(S) AFFORDING COVERAGE		NAIC #	INSURER A:	American Zurich Insurance Company	40142	INSURER B:	Zurich American Insurance Co	16535	INSURER C:	National Union Fire Ins. Co. of Pittsburgh, PA	19445	INSURER D:			INSURER E:			INSURER F:	
INSURER(S) AFFORDING COVERAGE		NAIC #																			
INSURER A:	American Zurich Insurance Company	40142																			
INSURER B:	Zurich American Insurance Co	16535																			
INSURER C:	National Union Fire Ins. Co. of Pittsburgh, PA	19445																			
INSURER D:																					
INSURER E:																					
INSURER F:																					
INSURED DKB, INC. 702 N California Ave Pasco, WA 99301																					

COVERAGES **CERTIFICATE NUMBER:** 8695956 **REVISION NUMBER:** See below

THIS IS TO CERTIFY THAT THE POLICIES OF INSURANCE LISTED BELOW HAVE BEEN ISSUED TO THE INSURED NAMED ABOVE FOR THE POLICY PERIOD INDICATED. NOTWITHSTANDING ANY REQUIREMENT, TERM OR CONDITION OF ANY CONTRACT OR OTHER DOCUMENT WITH RESPECT TO WHICH THIS CERTIFICATE MAY BE ISSUED OR MAY PERTAIN, THE INSURANCE AFFORDED BY THE POLICIES DESCRIBED HEREIN IS SUBJECT TO ALL THE TERMS, EXCLUSIONS AND CONDITIONS OF SUCH POLICIES. LIMITS SHOWN MAY HAVE BEEN REDUCED BY PAID CLAIMS.

INSR LTR	TYPE OF INSURANCE	ADDL SUBR INSD WVD	POLICY NUMBER	POLICY EFF (MM/DD/YYYY)	POLICY EXP (MM/DD/YYYY)	LIMITS
A	<input checked="" type="checkbox"/> COMMERCIAL GENERAL LIABILITY <input type="checkbox"/> CLAIMS-MADE <input checked="" type="checkbox"/> OCCUR <input checked="" type="checkbox"/> WA STOP GAP <input checked="" type="checkbox"/> \$5,000 PD DED GEN'L AGGREGATE LIMIT APPLIES PER: <input type="checkbox"/> POLICY <input checked="" type="checkbox"/> PRO-JECT <input type="checkbox"/> LOC OTHER:	X	CPO5761273 \$1M/\$1M/\$1M (EL)	7/1/14	7/1/15	EACH OCCURRENCE \$ 1,000,000 DAMAGE TO RENTED PREMISES (Ea occurrence) \$ 300,000 MED EXP (Any one person) \$ 10,000 PERSONAL & ADV INJURY \$ 1,000,000 GENERAL AGGREGATE \$ 2,000,000 PRODUCTS - COMP/OP AGG \$ 2,000,000
B	<input checked="" type="checkbox"/> AUTOMOBILE LIABILITY <input checked="" type="checkbox"/> ANY AUTO <input type="checkbox"/> ALL OWNED AUTOS <input checked="" type="checkbox"/> HIRED AUTOS <input type="checkbox"/> SCHEDULED AUTOS <input checked="" type="checkbox"/> NON-OWNED AUTOS	X	CPO5761272	7/1/14	7/1/15	COMBINED SINGLE LIMIT (Ea accident) \$ 1,000,000 BODILY INJURY (Per person) \$ BODILY INJURY (Per accident) \$ PROPERTY DAMAGE (Per accident) \$
C	<input checked="" type="checkbox"/> UMBRELLA LIAB <input checked="" type="checkbox"/> OCCUR <input checked="" type="checkbox"/> EXCESS LIAB <input type="checkbox"/> CLAIMS-MADE DED RETENTION \$ 0	X	BE025066044	7/1/14	7/1/15	EACH OCCURRENCE \$ 5,000,000 AGGREGATE \$ 5,000,000
B	WORKERS COMPENSATION AND EMPLOYERS' LIABILITY ANY PROPRIETOR/PARTNER/EXECUTIVE OFFICER/MEMBER EXCLUDED? (Mandatory in NH) If yes, describe under DESCRIPTION OF OPERATIONS below	Y/N Y N/A	WC5761272	7/1/14	7/1/15	<input checked="" type="checkbox"/> PER STATUTE OTH-ER E.L. EACH ACCIDENT \$ 1,000,000 E.L. DISEASE - EA EMPLOYEE \$ 1,000,000 E.L. DISEASE - POLICY LIMIT \$ 1,000,000

DESCRIPTION OF OPERATIONS / LOCATIONS / VEHICLES (ACORD 101, Additional Remarks Schedule, may be attached if more space is required)

JOB NAME: LA EXCULITA HIGH SCHOOL
 JOB LOCATION: OAKLAND, CA
 DKB JOB#: OAKLAND UNIFIED SCHOOL DISTRICT SHALL BE LISTED AS ADDITIONAL INSURED.

CERTIFICATE HOLDER**CANCELLATION**

OAKLAND UNIFIED SCHOOL DISTRICT
 955 HIGH STREET
 OAKLAND, CA 94601

SHOULD ANY OF THE ABOVE DESCRIBED POLICIES BE CANCELLED BEFORE THE EXPIRATION DATE THEREOF, NOTICE WILL BE DELIVERED IN ACCORDANCE WITH THE POLICY PROVISIONS.

AUTHORIZED REPRESENTATIVE

Jeanne Brada

Additional Insured – Automatic – Owners, Lessees Or Contractors



Policy No.	Eff. Date of Pol.	Exp. Date of Pol.	Eff. Date of End.	Producer No.	Add'l. Prem	Return Prem.
CPO5761273	7/1/14	7/1/15	7/1/14			

THIS ENDORSEMENT CHANGES THE POLICY. PLEASE READ IT CAREFULLY.

Named Insured: DKB, INC.
Address (including ZIP Code): 702 N California Ave
 Pasco, WA 99301

This endorsement modifies insurance provided under the:

Commercial General Liability Coverage Part

- A.** Section II – **Who Is An Insured** is amended to include as an insured any person or organization who you are required to add as an additional insured on this policy under a written contract or written agreement.
- B.** The insurance provided to the additional insured person or organization applies only to "bodily injury", "property damage" or "personal and advertising injury" covered under Section I - **Coverage A - Bodily Injury And Property Damage Liability** and Section I - **Coverage B - Personal And Advertising Injury Liability**, but only with respect to liability for "bodily injury", "property damage" or "personal and advertising injury" caused, in whole or in part, by:
 - 1. Your acts or omissions; or
 - 2. The acts or omissions of those acting on your behalf,
 and resulting directly from your ongoing operations or "your work" as included in the "products-completed operations hazard", which is the subject of the written contract or written agreement, performed for the additional insured person or organization.
- C.** However, regardless of the provisions of Paragraphs **A.** and **B.** above:
 - 1. We will not extend any insurance coverage to any additional insured person or organization:
 - a. That is not provided to you in this policy; or
 - b. That is any broader coverage than you are required to provide to the additional insured person or organization in the written contract or written agreement; and
 - 2. We will not provide Limits of Insurance to any additional insured person or organization that exceed the lower of:
 - a. The Limits of Insurance provided to you in this policy; or
 - b. The Limits of Insurance you are required to provide in the written contract or written agreement.
- D.** The insurance provided to the additional insured person or organization does not apply to:
 "Bodily injury", "property damage" or "personal and advertising injury" arising out of the rendering or failure to render any professional architectural, engineering or surveying services including:
 - 1. The preparing, approving or failing to prepare or approve maps, shop drawings, opinions, reports, surveys, field orders, change orders or drawings and specifications; and
 - 2. Supervisory, inspection, architectural or engineering activities.

E. The additional insured must see to it that:

1. We are notified as soon as practicable of an "occurrence" or offense that may result in a claim;
2. We receive written notice of a claim or "suit" as soon as practicable; and
3. A request for defense and indemnity of the claim or "suit" will promptly be brought against any policy issued by another insurer under which the additional insured may be an insured in any capacity. This provision does not apply to insurance on which the additional insured is a Named Insured, if the written contract or written agreement requires that this coverage be primary and non-contributory.

F. For the coverage provided by this endorsement:

1. The following paragraph is added to Paragraph **4.a.** of the Other Insurance Condition of Section **IV – Commercial General Liability Conditions**:

This insurance is primary insurance as respects our coverage to the additional insured person or organization, where the written contract or written agreement requires that this insurance be primary and non-contributory with respect to any other policy upon which the additional insured is a Named Insured. In that event, we will not seek contribution from any other such insurance policy available to the additional insured on which the additional insured person or organization is a Named Insured.

2. The following paragraph is added to Paragraph **4.b.** of the Other Insurance Condition of Section **IV – Commercial General Liability Conditions**:

This insurance is excess over:

Any of the other insurance, whether primary, excess, contingent or on any other basis, available to an additional insured, in which the additional insured on our policy is also covered as an additional insured on another policy providing coverage for the same "occurrence", offense, claim or "suit". This provision does not apply to any policy in which the additional insured is a Named Insured on such other policy and where our policy is required by written contract or written agreement to provide coverage to the additional insured on a primary and non-contributory basis.

- G.** This endorsement does not apply to an additional insured which has been added to this policy by an endorsement showing the additional insured in a Schedule of additional insureds, and which endorsement applies specifically to that identified additional insured.

All other terms and conditions of this policy remain unchanged.



SMALL CONSTRUCTION CONTRACT (CUPCCAA) ROUTING FORM

Project Information

Project Name	Metwest Educational Center	Site	121
---------------------	----------------------------	-------------	-----

Basic Directions

Services cannot be provided until the contract is fully approved and a Purchase Order has been issued.

Attachment Checklist	<input type="checkbox"/> Proof of general liability insurance, including certificates and endorsements, if contract is over \$15,000 <input type="checkbox"/> Workers compensation insurance certification, unless vendor is a sole provider
-----------------------------	---

Contractor Information

Contractor Name	DKB, Inc.	Agency's Contact	Don Gibison				
OUSD Vendor ID #	New Project	Title	Project Manager				
Street Address	49 Matmor Road	City	Woodland	State	CA	Zip	95776
Telephone	916-542-1572	Policy Expires	7-1-2015				
Contractor History	Previously been an OUSD contractor? <input type="checkbox"/> Yes <input checked="" type="checkbox"/> No		Worked as an OUSD employee? <input checked="" type="checkbox"/> Yes <input type="checkbox"/> No				
OUSD Project #	07047						

Term

Date Work Will Begin	3-11-2015	Date Work Will End By <small>(not more than 5 years from start date)</small>	6-11-2015
-----------------------------	-----------	--	-----------

Compensation

Total Contract Amount	\$	Total Contract Not To Exceed	\$9,886.80
Pay Rate Per Hour <small>(If Hourly)</small>	\$	If Amendment, Changed Amount	\$
Other Expenses		Requisition Number	

Budget Information

If you are planning to multi-fund a contract using LEP funds, please contact the State and Federal Office before completing requisition.

Resource #	Funding Source	Org Key	Object Code	Amount
7710	County School Facilities	1219903835	6274	\$9,886.80

Approval and Routing (in order of approval steps)

Services cannot be provided before the contract is fully approved and a Purchase Order is issued. Signing this document affirms that to your knowledge services were not provided before a PO was issued.

	Division Head	Phone	510-535-7038	Fax	510-535-7082
1.	Director, Facilities Planning and Management				
	Signature	Date Approved	2/4/15		
2.	General Counsel, Department of Facilities Planning and Management				
	Signature	Date Approved	2-4-15		
3.	Deputy Chief, Facilities Planning and Management				
	Signature	Date Approved	2/4/15		
4.	Chief Operations/Officer, Board of Education				
	Signature	Date Approved	2/17/15		
5.	President, Board of Education				
	Signature	Date Approved			