

Board Office Use: Legislative File Info.	
File ID Number	13-0335
Committee	Facilities
Introduction Date	2-13-2013
Enactment Number	13-0431
Enactment Date	2-27-13



OAKLAND UNIFIED
SCHOOL DISTRICT

Community Schools, Thriving Students

Memo

To Board of Education

From Tony Smith, Ph.D., Superintendent
Timothy White, Associate Superintendent, Facilities Planning and Management

Board Meeting Date February 13, 2013

Subject Amendment No. 1, Purchase Order Contract - JUV, Inc. - McClymonds Youth and Family Center Project

Action Requested Approval by the Board of Education of Amendment No. 1, Purchase Order Contract with JUV, Inc. for Post Construction Services on behalf of the District at McClymonds Youth and Family Center, in an amount not-to exceed \$9,453.00 increasing previous contract amount from \$10,695.00 to a not to exceed amount of 20,149.00 and revising the end date from June 28, 2012 through August 30, 2012 to December 31, 2013. All remaining portions of the agreement shall remain in full force and effect as originally stated.

Background The McClymonds Youth and Family Center opened its doors in February, 2012 to serve the student body. The MYFC will enhance and expand the provision of clinical services by linking two core initiatives (Chappell Hayes Health Center and Oakland Food and Fitness).

Local Business Participation Percentage 100.00%

Strategic Alignment Among the key purposes of the District's Facilities Master Plan is to provide an academic environment for the Oakland community that will give every student, educator, and community member using our facilities the best possible opportunity for learning.

Through implementation of the Facilities Master Plan, the District intends to improve the District's facilities in terms of structural integrity, safety, reliability of operating (mechanical) systems, access to modern resources,



number and type of appropriate laboratories and specialized instruction rooms, opportunities for physical education, and attractiveness, such that the Oakland Public Schools are second to none. Operation of the District schools under the planned approach is intended to ensure safety, cleanliness, and orderliness for all individuals participating in the learning process.

The basic facility needs of students such as proper lighting, functional roofs, noise control and well maintained buildings, not only convey the message that we value our students and teachers but may foster a sense of school pride and community ownership which may improve attitudes towards learning. The implementation of the Facilities Master Plan is our first step in that direction.

Recommendation

Approval by the Board of Education of Amendment No. 1, Purchase Order Contract with JUV, Inc. for Post Construction Services on behalf of the District at McClymonds Youth and Family Center, in an amount not-to exceed \$9,453.00 increasing previous contract amount from \$10,695.00 to a not to exceed amount of \$20,149.00 and revising the end date from June 28, 2012 through August 30, 2012 to December 31, 2013. All remaining portions of the agreement shall remain in full force and effect as originally stated.

Fiscal Impact

The funding sources for this project is: Special Reserve Fund.

Attachments

- Purchase Order Contract including scope of work



AMENDMENT NO. 1 TO PURCHASE ORDER CONTRACT

This Amendment is entered into between the Oakland Unified School District (OUSD) and JUV, INC. OUSD entered into an Agreement with CONTRACTOR for services on June 28, 2012, and the parties agree to amend that Agreement as follows:

1. Services: [] The scope of work is unchanged. [x] The scope of work has changed. If scope of work changed: Provide brief description of revised scope of work including description of expected final results, such as services, materials, products, and/or reports; attach additional pages as necessary. Attach revised scope of work. The CONTRACTOR agrees to provide the following amended services: The scope of work includes additional post construction items to complete necessary improvements in McClymonds Youth & Family Center and associated activity rooms; Work includes installing surveillance camera system to monitor various youth activity rooms remotely from the youth center reception desk. Work also includes installing a new observation window so staff can monitor activities between computer lab and main activity room.

2. Terms (duration): [] The term of the contract is unchanged. [x] The term of the contract has changed. If term is changed: The contract term is extended by an additional Twelve months, and the amended expiration date is December 31, 2013.

3. Compensation: [] The contract price is unchanged. [x] The contract price has changed. If the compensation is changed: The contract price is amended by [x] Increase of \$9,453.00 to original contract amount [] Decrease of \$ _____ to original contract amount and the new contract total is Twenty thousand, one hundred forty-nine dollars (\$20,149.00)

4. Remaining Provisions: All other provisions of the Agreement, and prior Amendment(s) if any, shall remain unchanged and in full force and effect as originally stated.

5. Amendment History: [x] There are no previous amendments to this Agreement. [] This contract has previously been amended as follows:

Table with 4 columns: No., Date, General Description of Reason for Amendment, Amount of Increase (Decrease). The table is currently empty.

6. Approval: This Agreement is not effective and no payment shall be made to Contractor until it is approved. Approval requires signature by the Board of Education, and the Superintendent as their designee.

OAKLAND UNIFIED SCHOOL DISTRICT



 David Kanashiba, President, Board of Education Date 2/28/13

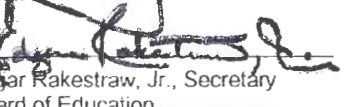

 Edgar Rakestraw, Jr., Secretary
 Board of Education Date 2/28/13
 Date

 Timothy White, Associate Superintendent
 Facilities, Planning and Management Date

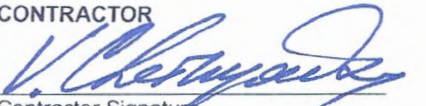
CONTRACTOR

 Contractor Signature Date 1/15/2013

V. CHERNYAVSKIY CEO.

 Print Name, Title

File ID Number: 13-0335
 Introduction Date: 2-27-13
 Enactment Number: 13-0431
 Enactment Date: 2-27-13
 By: ef

EXHIBIT "A" Scope of Work

Contractor Name:

Billing Rate: Nine thousand, four hundred fifty-three dollars and no cents (\$9,453.00)

Description of Services to be Provided

1. Description of Services to be Provided

Provide additional post construction items to complete necessary improvements.

2. Specific Outcomes:

To provide a safe place for students and staff at the McClymonds Youth Center.

3. Alignment with District Strategic Plan: Indicate the goals and visions supported by the services of this contract:

<input type="checkbox"/> Ensure a high quality instructional core	<input type="checkbox"/> Prepare students for success in college and careers
<input checked="" type="checkbox"/> Develop social, emotional and physical health	<input checked="" type="checkbox"/> Safe, healthy and supportive schools
<input type="checkbox"/> Create equitable opportunities for learning	<input type="checkbox"/> Accountable for quality
<input type="checkbox"/> High quality and effective instruction	<input type="checkbox"/> Full service community district

Oakland Unified School District or the District verifies that the Contractor does not appear on the Excluded Parties List at www.epls.gov/epls/search.do.

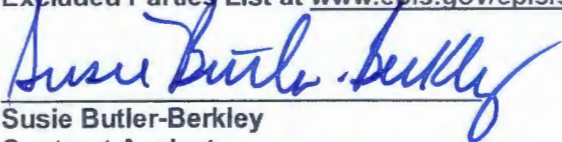

Susie Butler-Berkley
Contract Analyst

J.U.V. INC.
1616 Franklin Street, Suite#203
Oakland, CA 94612
TEL: (510) 836 1300 FAX: (510) 836 1301
Contractor Lic. #924181

EXHIBIT A

J.U.V. INC.

January 15, 2013

To: OUSD
Attn: Mary Ledezma
Re: McClymonds Youth Center

ESTIMATE

1. 48x48 hollow metal window is \$350
 2. 48x48 triplex glass is \$480
 3. Installation is \$620
 4. Miscellaneous materials are \$150
 5. Camera surveillance system \$6620
- | | |
|-------------|--------|
| Total | \$8220 |
| O & P 15% | \$1233 |
| Grand Total | \$9453 |

Sincerely,



Vladimir Chernyavskiy
CEO

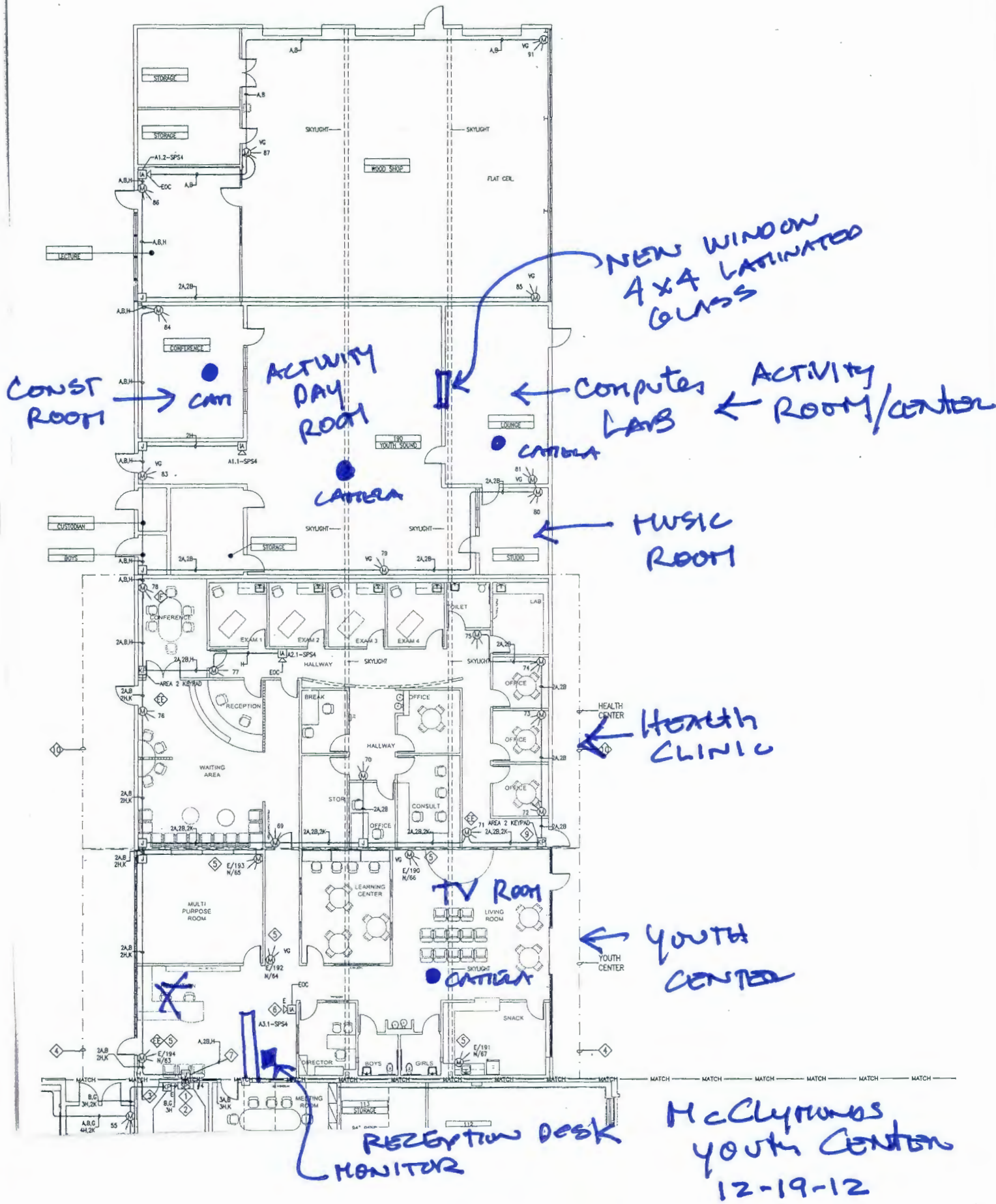



Chris Rivas
 PO Box 611178
 San Jose, CA 95161
 Ph: (408) 320-2352
 Fax: (855) 288-5851
 chris@empowerdsi.com

Estimate

Date	Estimate #
4/30/2012	1071

Bill To:
Oakland Unified School District Mary Ledezma 955 High Street Oakland, CA 94601

Project Location:
McClymonds Youth and Family Center McClymonds High School 2607 Myrtle Street Oakland, CA

****Please include the Estimate number on all Purchase Orders, Authorizations and future correspondence.****

Sales Rep	P.O. No.	Project	Terms
Chris		1071 Surveillance System	Due on receipt

Qty	Description	Rate	Total
1.00	4 Channel Digital Video Recording Server, 1TB	968.00	968.00T
4.00	Costar 4-9mm interior/exterior vandal res/ weather res color dome camera w/ IR	299.20	1,196.80T
2.00	19" LCD display	270.40	540.80T
1.00	desk top dvr lockbox	302.40	302.40T
4.00	RG59/18-2 Siamese video cable - white 500' spool non plenum	161.9675	647.87T
1.00	cat5 patchcable	20.80	20.80T
1.00	Labor - provide all listed cable, parts and programming to deliver a functional 4-camera NVR camera system capable of local view and playback from each of two separate locations (reception desk and day room area), network access via Lan/Wan, smartphone accessibility for view and playback. Empower will install cable from camera locations to a single termination point at the reception desk where the nvr, lockbox for nvr and fused power supply will be located (under desk, monitor on desk). Program with IP address information (provided by others) and connect to local area network connection (others).	2,640.00	2,640.00

Thank you for the opportunity to provide you with pricing!

Customer Signature & Date: _____

Subtotal	\$6,316.67
Sales Tax (8.25%)	\$303.33
Total	\$6,620.00

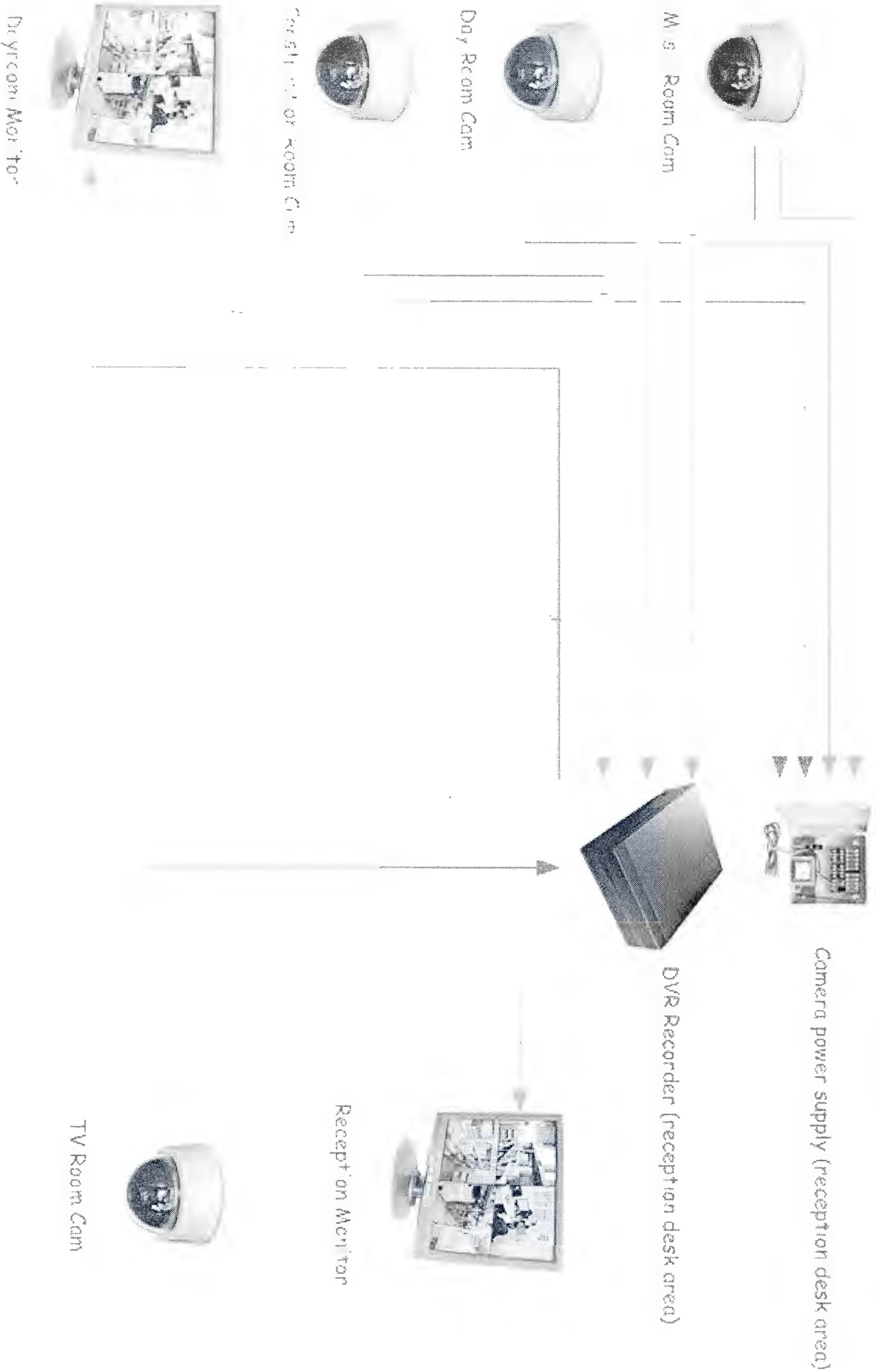



JUVINC0-01

ADINEROS

CERTIFICATE OF LIABILITY INSURANCE

DATE (MM/DD/YYYY)

1/24/2013

THIS CERTIFICATE IS ISSUED AS A MATTER OF INFORMATION ONLY AND CONFERS NO RIGHTS UPON THE CERTIFICATE HOLDER. THIS CERTIFICATE DOES NOT AFFIRMATIVELY OR NEGATIVELY AMEND, EXTEND OR ALTER THE COVERAGE AFFORDED BY THE POLICIES BELOW. THIS CERTIFICATE OF INSURANCE DOES NOT CONSTITUTE A CONTRACT BETWEEN THE ISSUING INSURER(S), AUTHORIZED REPRESENTATIVE OR PRODUCER, AND THE CERTIFICATE HOLDER.

IMPORTANT: If the certificate holder is an ADDITIONAL INSURED, the policy(ies) must be endorsed. If SUBROGATION IS WAIVED, subject to the terms and conditions of the policy, certain policies may require an endorsement. A statement on this certificate does not confer rights to the certificate holder in lieu of such endorsement(s).

PRODUCER Walsh Carter & Associates Insurance Services, LLC 425 California Street, #400 San Francisco, CA 94104	CONTACT NAME: PHONE (A/C, No, Ext): (415) 217-6200 E-MAIL ADDRESS:	FAX (A/C, No): (415) 217-6201
	INSURER(S) AFFORDING COVERAGE	
INSURED JUV, Inc. 1616 Franklin Street, Suite 203 Oakland, CA 94612	INSURER A: Landmark American Insurance Co NAIC # 33138	
	INSURER B: Integon National Insurance Company	
	INSURER C: RSUI Indemnity Company	
	INSURER D: Everest National Insurance Company	
	INSURER E: American Safety Indemnity	
	INSURER F: Lloyd's of London	

COVERAGES**CERTIFICATE NUMBER:****REVISION NUMBER:**

THIS IS TO CERTIFY THAT THE POLICIES OF INSURANCE LISTED BELOW HAVE BEEN ISSUED TO THE INSURED NAMED ABOVE FOR THE POLICY PERIOD INDICATED. NOTWITHSTANDING ANY REQUIREMENT, TERM OR CONDITION OF ANY CONTRACT OR OTHER DOCUMENT WITH RESPECT TO WHICH THIS CERTIFICATE MAY BE ISSUED OR MAY PERTAIN, THE INSURANCE AFFORDED BY THE POLICIES DESCRIBED HEREIN IS SUBJECT TO ALL THE TERMS, EXCLUSIONS AND CONDITIONS OF SUCH POLICIES. LIMITS SHOWN MAY HAVE BEEN REDUCED BY PAID CLAIMS.

INSR LTR	TYPE OF INSURANCE	ADDL INSR	SUBR WVD	POLICY NUMBER	POLICY EFF (MM/DD/YYYY)	POLICY EXP (MM/DD/YYYY)	LIMITS	
A	<input checked="" type="checkbox"/> GENERAL LIABILITY	<input checked="" type="checkbox"/>		LHA135967	3/18/2012	3/18/2013	EACH OCCURRENCE \$ 1,000,000	
	<input checked="" type="checkbox"/> COMMERCIAL GENERAL LIABILITY						DAMAGE TO RENTED PREMISES (Ea occurrence) \$ 50,000	
	<input type="checkbox"/> CLAIMS-MADE <input checked="" type="checkbox"/> OCCUR						MED EXP (Any one person) \$ 0	
	GEN'L AGGREGATE LIMIT APPLIES PER:						PERSONAL & ADV INJURY \$ 1,000,000	
	<input type="checkbox"/> POLICY <input checked="" type="checkbox"/> PRO-JECT <input type="checkbox"/> LOC						GENERAL AGGREGATE \$ 2,000,000	
B	<input type="checkbox"/> AUTOMOBILE LIABILITY			12000369	6/29/2012	6/29/2013	COMBINED SINGLE LIMIT (Ea accident) \$ 1,000,000	
	<input type="checkbox"/> ANY AUTO						<input checked="" type="checkbox"/> SCHEDULED AUTOS	BODILY INJURY (Per person) \$
	<input type="checkbox"/> ALL OWNED AUTOS						<input checked="" type="checkbox"/> NON-OWNED AUTOS	BODILY INJURY (Per accident) \$
	<input checked="" type="checkbox"/> HIRED AUTOS							PROPERTY DAMAGE (PER ACCIDENT) \$
C	<input checked="" type="checkbox"/> UMBRELLA LIAB <input checked="" type="checkbox"/> OCCUR			NHA231325	9/17/2012	3/18/2013	EACH OCCURRENCE \$ 4,000,000	
	<input checked="" type="checkbox"/> EXCESS LIAB <input type="checkbox"/> CLAIMS-MADE						AGGREGATE \$	
	DED <input type="checkbox"/> RETENTION \$						\$ 4,000,000	
D	<input checked="" type="checkbox"/> WORKERS COMPENSATION AND EMPLOYERS' LIABILITY			7600009830121	9/28/2012	9/28/2013	<input checked="" type="checkbox"/> WC STATUTORY LIMITS <input type="checkbox"/> OTH-ER	
	<input type="checkbox"/> ANY PROPRIETOR/PARTNER/EXECUTIVE OFFICER/MEMBER EXCLUDED? (Mandatory in NH)						E.L. EACH ACCIDENT \$ 1,000,000	
	If yes, describe under DESCRIPTION OF OPERATIONS below						E.L. DISEASE - EA EMPLOYEE \$ 1,000,000	
E	CPL			CPL032745-12-01	10/2/2012	10/2/2013	AGGREGATE \$ 5,000,000	
F	Professional Liablt			B0621PJUV002121	10/9/2012	10/9/2013	AGGREGATE \$ 1,000,000	

DESCRIPTION OF OPERATIONS / LOCATIONS / VEHICLES (Attach ACORD 101, Additional Remarks Schedule, if more space is required)

*10 DAY NOTICE OF CANCELLATION MAY BE ISSUED FOR NONPAYMENT OF PREMIUM/ NONREPORTING OF PAYROLL.

Oakland Unified School District and its directors, officers, employees, agents and representatives are NAMED AS ADDITIONAL INSUREDS WHERE PRIMARY WORDING ALSO APPLIES PER ATTACHED ENDORSEMENT, ONLY IF STIPULATED UNDER THE CONDITIONS OF THE WRITTN CONTRACT/ AGREEMENT.
 Project location: McClymonds High School 2607 Myrtle Street Oakland, CA

CERTIFICATE HOLDER**CANCELLATION**

McClymonds Youth and Family Center
 McClymonds High School
 2607 Myrtle Street
 Oakland, CA 94608

SHOULD ANY OF THE ABOVE DESCRIBED POLICIES BE CANCELLED BEFORE THE EXPIRATION DATE THEREOF, NOTICE WILL BE DELIVERED IN ACCORDANCE WITH THE POLICY PROVISIONS.

AUTHORIZED REPRESENTATIVE

[Signature]

© 1988-2010 ACORD CORPORATION. All rights reserved.

This Endorsement Changes The Policy. Please Read It Carefully.

ADDITIONAL INSURED BLANKET – PRIMARY AND YOUR WORK

This endorsement modifies insurance provided under the following:

COMMERCIAL GENERAL LIABILITY COVERAGE FORM

SCHEDULE

Name of Person or Organization: Any person or organization to whom or to which you are obligated by virtue of a written contract or by the issuance or existence of a written permit, to provide insurance such as is afforded by this policy.

- A. SECTION II - WHO IS AN INSURED** is amended to include as an additional insured the person(s) or organization(s) shown in the SCHEDULE, but only with respect to liability for "bodily injury", "property damage" or "personal and advertising injury" caused, in whole or in part, by:
1. Your acts or omissions; or
 2. The acts or omissions of those acting on your behalf;
- in the performance of your ongoing operations; and/or "your work" defined for the additional insured(s) designated above included in the "products-completed operations hazard".
- B.** If you are required by a written contract to provide primary insurance, this policy shall be primary and **SECTION IV – COMMERCIAL GENERAL LIABILITY CONDITIONS, 4. Other Insurance** does not apply, but only with respect to coverage provided by this policy.

This endorsement effective 3/18/2012
forms part of Policy Number LHA135967
issued to J U V INC
by Landmark American Insurance Company

AMENDMENT TO PURCHASE ORDER CONTRACT ROUTING FORM

Project Information			
Project Name	McClymonds Youth and Family Center	Site	MdClymonds Youth and Family Center
Basic Directions			
Services cannot be provided until the contract is fully approved and a Purchase Order has been issued.			
Attachment Checklist	<input type="checkbox"/> Proof of general liability insurance, including certificates and endorsements, if contract is over \$15,000 <input type="checkbox"/> Workers compensation insurance certification, unless vendor is a sole provider		

Contractor Information					
Contractor Name	JUV, Inc.	Agency's Contact	Vladimir Chernyavskiy		
OUSD Vendor ID #	V060124	Title	Project Manager		
Street Address	1616 Franklin Street, Suite 203	City	Oakland	State	Ca
Telephone	510-836-1300	Policy Expires	3-16-2013		
Contractor History	Previously been an OUSD contractor? <input checked="" type="checkbox"/> Yes <input type="checkbox"/> No		Worked as an OUSD employee? <input type="checkbox"/> Yes <input checked="" type="checkbox"/> No		
OUSD Project #	07051				

Term			
Date Work Will Begin	6-28-2012	Date Work Will End By (not more than 5 years from start date)	12-31-2013

Compensation			
Total Contract Amount	\$	Total Contract Not To Exceed	\$20,149.00
Pay Rate Per Hour (If Hourly)	\$	If Amendment, Changed Amount	\$ 9,453.00
Other Expenses		Requisition Number	

Budget Information				
If you are planning to multi-fund a contract using LEP funds, please contact the State and Federal Office before completing requisition.				
Resource #	Funding Source	Org Key	Object Code	Amount
9216	Special Reserve Fund	3039003890	6274	\$9,453.00

Approval and Routing (in order of approval steps)						
Services cannot be provided before the contract is fully approved and a Purchase Order is issued. Signing this document affirms that to your knowledge services were not provided before a PO was issued.						
1.	Division Head	Charles Love	Phone	510-535-7081	Fax	510-535-7-82
	Capital Program Contract & Accounting Manager					
	Signature			Date Approved	1-24-13	
2.	General Counsel, Department of Facilities Planning and Management					
	Signature			Date Approved	1-30-13	
3.	Associate Superintendent, Facilities Planning and Management					
	Signature			Date Approved		
4.	President, Board of Education					
	Signature			Date Approved		

Board Office Use: Legislative File Info.	
File ID Number	12-2150
Committee	Facilities
Introduction Date	8-1-2012
Enactment Number	12-2219
Enactment Date	8/1/12 OR



OAKLAND UNIFIED
SCHOOL DISTRICT

Memo

To Board of Education

From Tony Smith, Ed.D., Superintendent
Timothy White, Associate Superintendent, Facilities Planning and Management

Board Meeting Date August 15, 2012

Subject Division of Facilities Planning and Management P.O.'s. Less than \$50,000.00

Action Requested: Ratification by the Board of Education of the attached contracts for the Division of Facilities Planning and Management.

	NAME	AMOUNT	FUND NAME	P.O.	LOCATION	DATES	CITY
12-2129	AT&T	\$25,200.00	Developer Fee Fund 25	P.O.	La Escuelita Educational Center	6-11-2012 thru 12-31-2012	Sacramento, CA
12-2130	B.P. Wood, Inc.	\$48,438.00	Developer Fee Fund 25	P.O.	Site Reutilization at Lakeview	7-13-2012 thru 6-30-2013	San Jose
12-2131	Cahill/Focan JV	\$30,000.00	Measure B	P.O.	Calvin Simmons . Improvements and Career Lab	4-6-2012 thru 5-29-2012	Oakland, CA
12-2132	CDW Government	\$51,656.25	County School Facilities Fund 35	P.O.	La Escuelita Education	5-23-2012 thru 12-31-2012	Chicago, IL
12-2133	CDW Government	\$989.63	Developer Fee Fund 25	P.O.	La Escuelita Educational Center	5-3-2012 thru 7-31-2012	Chicago, IL
12-2134	Chussy International	\$729.00	Measure A	P.O.	Facilities	5-10-2012 thru 5-18-2012	Oakland
12-3125	Chussy International	\$5,565.00	Measure A	P.O.	Facilities	6-30-2012 thru 6-30-2013	Oakland
12-2137	Cor-O-Data	\$455.00	Measure A	P.O.	Facilities	6-13-2012 thru 4-30-2013	Richmond
12-2138	Creation Engine, Inc.	\$1,766.31	Measure A	P.O.	Facilities	3-27-2012 thru 4-47-2012	Mt. View
12-3139	DFS	\$3,975.00	Developer Fees Fund 25	P.O.	Facilities Reutilization	7-13-2012 thru 6-30-2013	Foster City
12-2140	East Bay Restaurant Supply, Inc.	\$75,000.00	Measure B	P.O.	Oakland HS Lunch	6-1-2012 thru 12-31-	Oakland



OAKLAND UNIFIED
SCHOOL DISTRICT

2-2161	Pitney Bowes	\$5,000.00	Measure A	P.O.	Facilities	7-1-2012 thru 6-30- 2013	Louisville, KY
2-2162	R&S Overhead Garage Door, Inc.	\$2,700.00	County School Facilities Fund 35	P.O.	La Escuelita Educational Center Phase 2	4-10-2012 thru 6-30- 2012	San Leandro
2-2163	SCA Environmental	\$1,070.00	Grant Fund	P.O.	Chabot Caldecott Tunnel Air Quality Grant	5-23-2012 thru 12-31- 2012	Oakland
2-2164	Signawest Systems Inc.	\$5,708.00	Grant Funds	P.O.	McClymonds Youth & Family Center	5-8-2012 thru 12-31- 2012	Newark
2-2165	Skyline Engineering	\$9,800.00	County School Facilities Fund 35	P.O.	District-wide	5-2-2012 thru 12-31- 2012	Salinas
2-2166	Steel Inspectors of Texas, Inc.	\$225.00	Measure B	P.O.	Grass Valley ES Portable Installation	6-1-2012 thru 8-15- 2012	Fort Worth, TX
2-2167	Steel Inspectors of Texas, Inc.	\$225.00	Measure B	P.O.	Burckhalter ES Portable Installation	6-1-2012 thru 12-31- 2012	Fort Worth, TX
2-2168	Syska Hennessy	\$50,000.00	Developer Fee Fund 25	P.O.	District-wide	5-1-2012 thru 6-1- 2012	San Francisco
2-2169	Telemex Communication	\$32,900.00	Developer Fee Fund 25	P.O.	Facilities Site Reutilization	7-13-2012 thru 6-30- 2013	Dublin

Discussion:

Among the key purposes of the District's Facilities Master Plan is to provide an academic environment for the Oakland community that will give every student, educator, and community member using our facilities the best possible opportunity for learning.

Through implementation of the Facilities Master Plan, the District intends to improve the District's facilities in terms of structural integrity, safety, reliability of operating (mechanical) systems, access to modern

physical education, and attractiveness, such that the Oakland Public Schools are second to none. Operation of the District schools under the planned approach is intended to ensure safety, cleanliness, and orderliness for all individuals participating in the learning process.

The basic facility needs of students such as proper lighting, functional roofs, noise control and well maintained buildings, not only convey the message that we value our students and teachers but may foster a sense of school pride and community ownership which may improve attitudes towards learning. The implementation of the Facilities Master Plan is our first step in that direction.

Fiscal Impact:

Various

Recommendation:

OAKLAND UNIFIED SCHOOL DISTRICT
Department of Facilities Planning and Management
AGREEMENT REQUEST FORM

1060124

DATE SUBMITTED: 5/9/2012
 SUBMITTED BY: Mary Ledezma

SECTION I. TYPE OF AGREEMENT (PLEASE CHECK ONE BOX)

- | | |
|---|---|
| 1.) A/E (Architect and Engineers) Contract <input type="checkbox"/> | 5.) "Small" (under \$15,000.00) Construction Contract <input checked="" type="checkbox"/> |
| 2.) IOR (Inspector of Record Contract) <input type="checkbox"/> | 6.) Resolution Awarding Bid and Construction Contract <input type="checkbox"/> |
| 3.) Agreement for Professional Services - Testing Etc. <input type="checkbox"/> | 7.) Change Order <input type="checkbox"/> |
| 4.) Amendment to Agreement for Professional Services <input type="checkbox"/> | 8.) Purchase Order <input checked="" type="checkbox"/> |

Vendor Number: _____
 Fiscal Year: _____
 P.O. #: _____
 Date Proc.: 5/10/12
 To: MB _____ To DR: _____

 Timothy E. White
 Asst. Superintendent

 Tadashi Nakadegawa
 Facilities Director

SECTION II. LOCAL BUSINESS PARTICIPATION PERCENTAGE:

Local Business	Small Local Business	Small Local Resident Business	Total Percentage
100.00%	0.00%	0.00%	100.00%

SECTION III. AGREEMENT INFORMATION:

Project Name: McClymonds Youth & Family Center
 Vendor Name: JUV, Inc
 Vendor Phone Number: (510) 836-1300
 Agreement Start and Stop Dates: Start: 6-28-12, Stop: 9-30-12
 Has Work Started? Yes No
 If yes give an explanation:
 Certificate of Insurance Attached Yes No

Project No: 07051
 Vendor Contact: Vladimir Chernyavskiy 6271
 Vendor Mailing Address: 1616 Franklin Street, Suite 203, Oakland, Ca. 94612
 Amounts: Current Contract Amount: \$0.00, Not to Exceed Amount: \$10,696.00, Revised Contract Amount: \$0.00
 Has Work Been Completed? Yes No
 Date: _____
 Vendor Number: _____
 Fiscal Year: 2011-2012
 P.O. Under \$50K: _____
 Date Processed: 5/31/2012
 To: MB 9/31 To DR: _____

- | | | | | |
|--------------------------------------|--|-------------------------------|-----------------------------|------------------------------|
| 1) Number of Bids Received: _____ | 2) Date(s) of Bid Advertisement: 8-15-2012 | 3) Date of Bid Opening: _____ | 4) Name of Architect: _____ | 5) Liquidated damages: _____ |
| 6) Performance Bonds Attached: _____ | 7) Payment Bonds Attached: _____ | 8) _____ | | |

Scope of Work: (Needed to prepare Executive Summary) Please attach separately along with Vendor's proposal.
 Scope includes post construction items required to complete necessary improvements in McClymonds Youth & Family Center. Work includes: new refrigerator and microwave for snack room, plumbing water to new refrigerator ice maker, adding window in existing door to dance floor and various door hardware changes.

Discussion Info: (Needed to prepare Executive Summary) (Provide detailed background - Why is contract required and what is the benefit to students) - Add additional pages as needed
 The McClymonds Youth & Family Center opened its doors in February 2012 to serve the student body. MYFC will enhance and expand the provision of clinical services by linking two core initiatives (Chappell Hayes Health Center and Oakland Food and Fitness).

Funding Source: County Grant

Budget Number: _____

RECEIVED
 5-14-2012

JUV Inc.

BID - PROPOSAL

DATE: May 4, 2012

PROPOSAL NO: 0024

PROPOSAL SUBMITTED TO:

OUSD

Mary Ledezma

WORK TO BE PERFORMED AT:

McClymonds Youth & Family Center

Oakland

CA

Phone

Fax

Construction To Begin: May 15, 2012

Contract Completion Date: May 30, 2012

We hereby propose to furnish all materials and necessary equipment, and perform all labor necessary to complete the following work:

- 1. Add window to existing door with laminated tempered glass - \$1500 ✓
 - 2. Provide GE Refrigerator CFCP1NIZSS -\$2016+TAX=\$2193 Add delivery charge \$400 Total: \$2593 ✓
 - 3. Provide new KitchenAid countertop mounted Microwave KCMS1555S-\$479 + TAX = \$488 ✓
 - 4. Provide plumbing hook-up for refrigerator -\$500 ✓
 - 5. Switch 2 wall mounted signs -\$100 ✓
 - 6. Change lockset to a STOREFRONT function -\$620 ✓
 - 7. Provide local alarm door control for back door - \$2835 2000.00 M.L.
 - 8. Allowance - \$2000 1500.00 M.L.
- TOTAL: \$10,636 9300.00

ADD OVERHEAD and PROFIT 15%

GRAND TOTAL: \$12,231 M.L.

\$ 10,696

M. LEDEZMA

All material is guaranteed to be as specified, and the above work to be performed in accordance with the drawings and specifications submitted for above work and completed in a substantial workmanlike manner for the sum of dollars (\$ 12,231.00) with payments to be made as follows:

You, the homeowner (buyer) or tenant have the right to require the contractor to furnish you with a performance bond. You, the buyer, may cancel this transaction at any time prior to midnight of the third business day after the date of this transaction. Cancellation by the buyer after the right to rescind has passed, shall be deemed a material breach of this agreement and entitles the contractor to damages.

Contractors are required by law to be licensed and regulated by the Contractors' State License Board which has jurisdiction to investigate and discipline contractors if not completed...

State License Board, P.O. Box 26000, Sacramento, California 95826.

Respectfully Submitted,

JUV Inc.

1616 Franklin Street, Suite #203

By:

[Signature] CHERNYAVSKY

Oakland

CA 94612

Contractor's License #: Prime's Lic. No.924181

Phone: (510) 836-1303

Fax: (510) 836-1301

Acceptance of Proposal.

Date: _____

(Owner Signature)

Note: This proposal may be withdrawn by us if not accepted within 30 days. If this Bid-Proposal is accepted, work will commence approximately on or about May 15, 2012, and will be substantially completed approximately 30 days thereafter.

THIS BID-PROPOSAL IS NOT A CONTRACT. THIS BID PROPOSAL MAY ONLY BE ACCEPTED BY THE EXECUTION OF A WRITTEN CONSTRUCTION AGREEMENT SIGNED BY THE CONTRACTOR. NO CONTRACT IS FORMED UNTIL A SEPARATE WRITTEN CONSTRUCTION AGREEMENT IS EXECUTED.

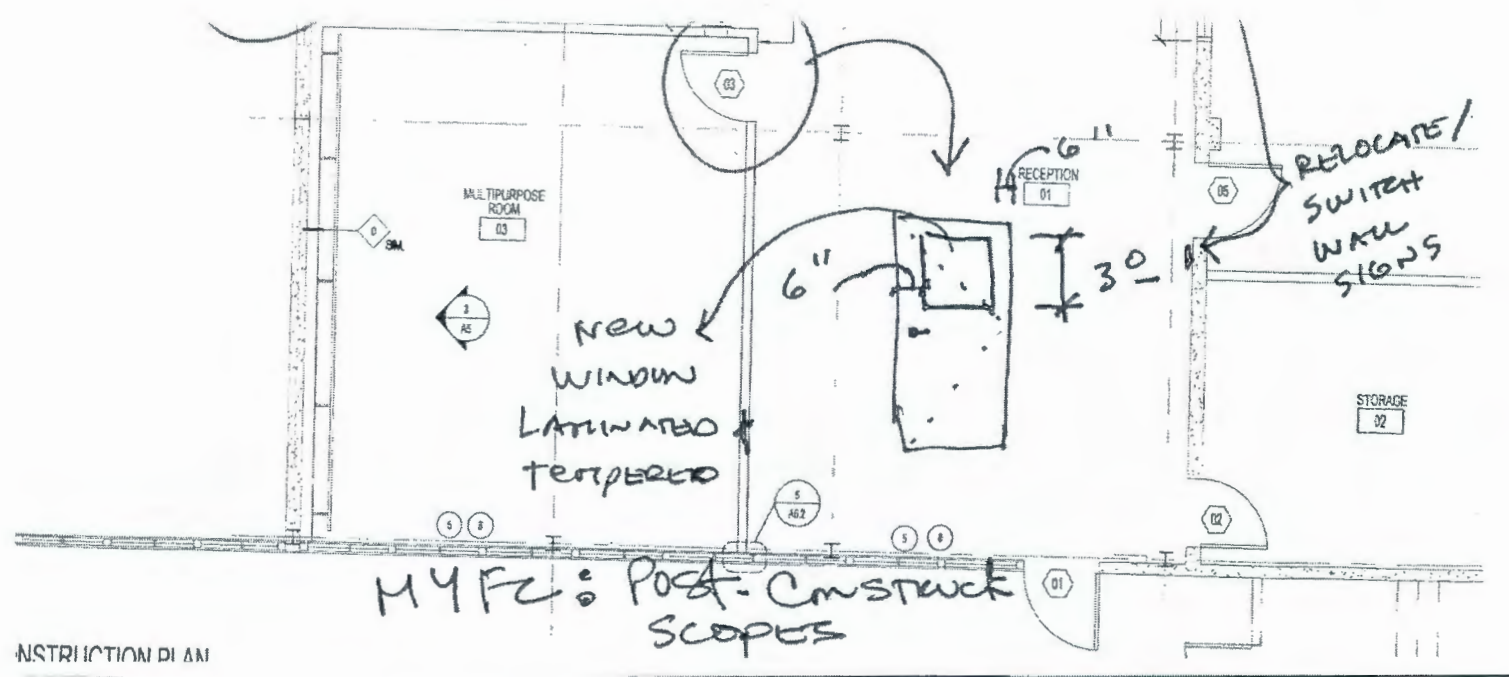
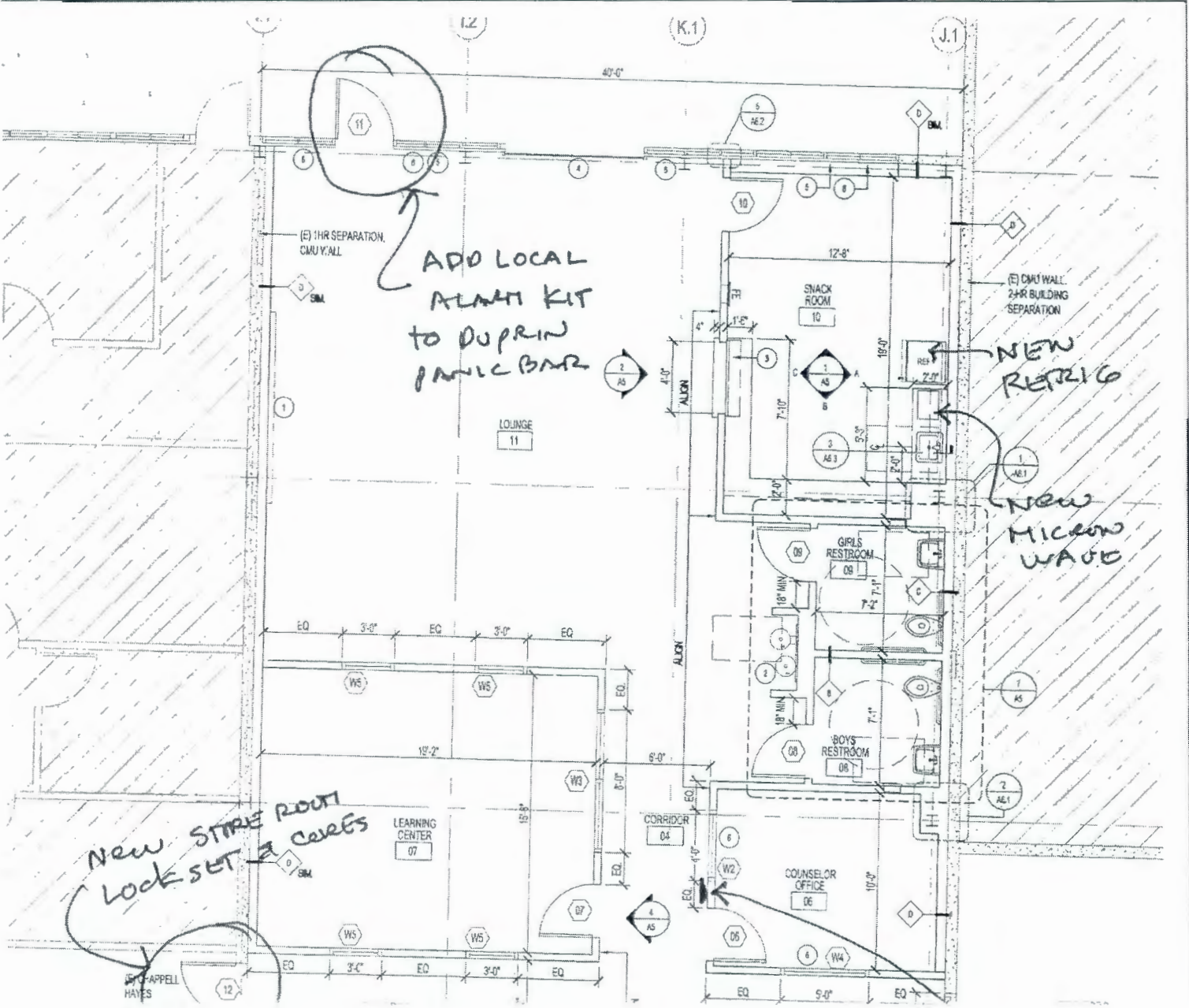

CFCP1NIZ

GE Café™ 20.9 Cu. Ft. Counter Depth French Door Refrigerator

Dimensions and Installation Information (in inches)

Overall Dimensions	Height to top of hinge (in.) A	69-5/8
	Height to top of case (in.) B	69
	Case depth without door (in.) C	23-7/8
	Case depth less door handle (in.) D	28-1/2
	Case depth with door handle (in.) E	31
	Depth with fresh food door open 90° (in.) F	43-1/2
	Width (in.) G	35-7/8
Air Clearances	Width with door open 90° inc. door handle (in.) H	44
	Each side (in.)	1/8
	Top (in.)	1
	Back (in.)	1/2

Dimensions (in inches)

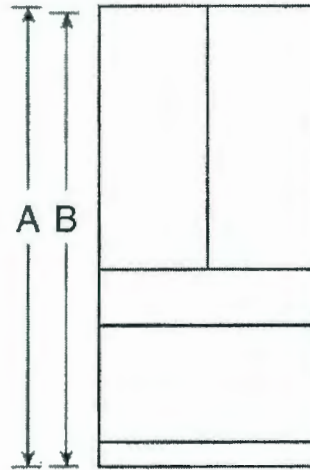

Front View

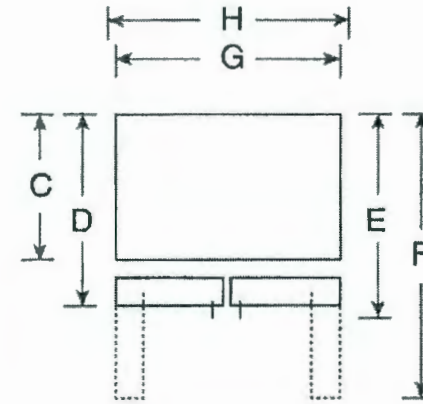

Top View

Above illustration intended for dimensional reference only. Refer to photography for actual product appearance.

For answers to your Monogram,® GE Profile™ or GE® appliance questions, visit our website at geappliances.com or call GE Answer Center® service, 800.626.2000.



imagination at work



Specification Created 1/10

210816

CFCP1NIZ

GE Café™ 20.9 Cu. Ft. Counter Depth French Door Refrigerator

Features and Benefits

- Counter-depth configuration - Counter-depth configuration makes it possible to have the look of a built-in without the added expense
- Stainless steel doors with hidden hinges - Up to a striking finish with rounded doors and a clean, elegant look
- ClimateKeeper™ system - Electronic controls, multiple electronic sensors and a multi-flow air system help provide even cooling
- Upfront temperature controls with actual temperature display - Easy-to-reach, easy-to-read controls display accurate temperatures
- Internal water dispenser with GE water filtration - Clean filtered, chilled water is available with just a touch
- Factory-installed icemaker with water filtration system - Refrigerator comes ready to automatically create filtered ice
- BrightSpace™ interior with GE Reveal® light interior lighting - It's easy to find tasty treats under bright, clear interior lighting
- Freshness Center™ with full-width drawer crispers and a full-width drawer - Maintain fresh tastes with two humidity-controlled crispers and a full-width drawer
- Multi-level Slide 'n Store™ system - You'll have instant access to frozen foods in three full-extension baskets
- In-the-door condiment bin and beverage holder - Cans and condiments are chilled and ready without taking up valuable shelf space
- QuickSpace™ shelf - Tall containers area served with a quick slide of the retractable shelf
- TurboCool™ setting - Restores proper temperature to the refrigerator after frequent door openings
- CFCP1NIZSS - Stainless Steel

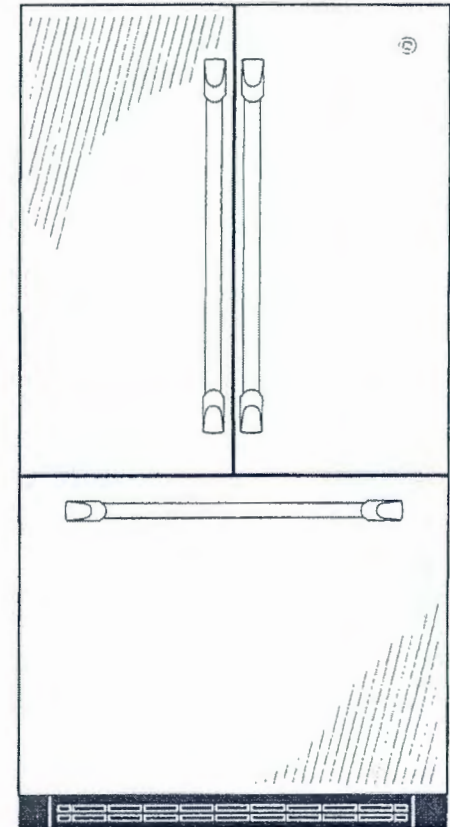

imagination at work

KitchenAid® Countertop Microwave Ovens

PRODUCT MODEL NUMBERS

KCMS1555S

Electrical: A 120-volt, 60 Hz, AC-only, 15 or 20 amp fused electrical supply with a fuse or circuit breaker is required. It is recommended that a separate circuit serving only this appliance be provided.

OVERALL DIMENSIONS

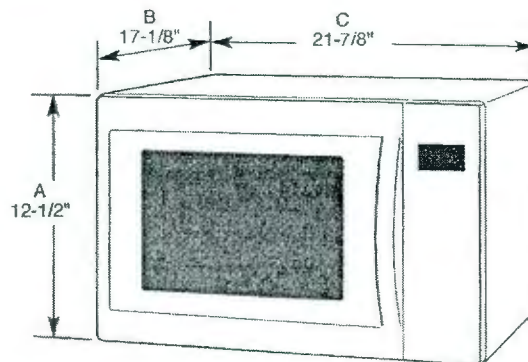

Height (A)	12-1/2"
Depth (B)	17-1/8"
Width (C)	21-7/8"

NOTE: Microwave oven can be built into a wall or cabinet over over approved electric single ovens only using approved trim kits. See dealer for details.

NOTE: Do not block the exhaust vents or air intake openings. Allow a few inches of space at the back and side of the oven where the exhaust vents are located. Blocking the exhaust vents could cause damage to the oven and poor cooking results.

VON DUPRIN

Installation Instructions



941042-00

33/35 and 98/99 Series ALK Alarm Kit

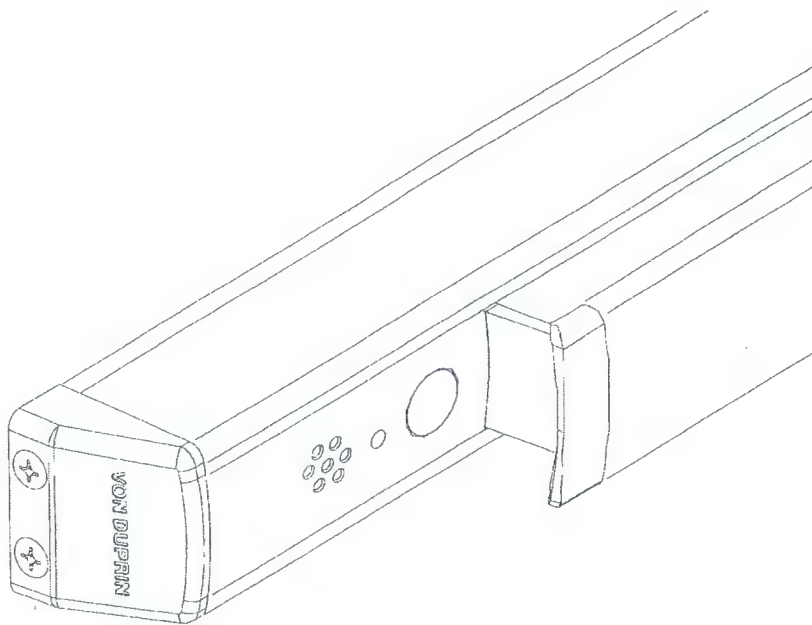

Index:

• General Information	2
• Parts List	2
• Installation	3
• Wiring	5
• Operating Instructions	7
• Changing the Battery	8