

OAKLAND UNIFIED SCHOOL DISTRICT
Office of the Superintendent

June 13, 2012

Legislative File

File ID No.: 12-1568

Introduction Date: 06/13/2012

Enactment No.: 12-1611

Enactment Date: 6-13-12 

TO: Board of Education

FROM: 
Dr. Anthony Smith, Superintendent
Timothy E. White, Assistant Superintendent of Facilities Planning and Management,
Building & Grounds, and Custodial Services

SUBJECT: Prop. 39 Facilities Use Agreement for 2012-2013 School Year

ACTION REQUESTED:

Approve the proposed Facilities Use Agreement to be made between Oakland Unified School District and Bay Area Technology School under the Proposition 39 statute, wherein charter schools are granted the right to request facilities allocations from the school district in which they reside, commensurate with the in-district ADA of the charter school.

SUMMARY:

Following a period of final offer and acceptance of facility use as required under state statute; staff recommends the approval of the final Facilities Use Agreement under Proposition 39, as outlined in the attached agreement with the specific facility space allocation and fees shown in the exhibits.

Each Proposition 39 application submitted pursuant to statute requirements was evaluated to determine the specific facilities needs that the District was obligated to meet. To the extent possible, OUSD attempted to match charter school facility requests with space available, based on the compatibility of the following features:

- The quantity of classroom space requested and the excess classroom space available.
- The grade served by each program when programs are co-located.
- The school program and the site.
- The location requested and the location available.

The facilities charge in the Facilities Use Agreement is established at \$2.95 per square foot, per year, based on an analysis by Facilities Counsel and the Chief Financial Officer as to the applicable costs associated with the statute.

The attached agreement and its exhibits outline the total square footage and teaching stations to be provided under Proposition 39. It also identifies the specific space to be used by the charter school for the period required by statute.

BACKGROUND:

Under the California Education Code Section 47614, "Each school district shall make available, to each charter school operating in the school district, facilities sufficient for the charter school to accommodate all of the charter school's in-district students in conditions reasonably equivalent to those in which the students would have been accommodated if they were attending other public schools of the district."

Under this statute, the District is obligated to provide facilities to requesting charter schools operating within Oakland Unified attendance boundaries. The period for which these facilities will be provided for use by the requesting charter school is one academic school year only: 2012-2013. The requesting charter school may submit a subsequent Prop. 39 facilities request for the ensuing school years, pursuant to the requirements of the statute and applicable legislation, which will then be evaluated within the context of the District's continued capacity to provide such facilities.

RECOMMENDATION:

It is the recommendation of staff to approve the proposed Facilities Use Agreement between the Oakland Unified School District and Bay Area Technology School under Proposition 39 as outlined in the attached agreement.



**PROPOSITION 39 CHARTER FACILITIES USE AGREEMENT
BY AND BETWEEN OAKLAND UNIFIED SCHOOL DISTRICT AND
BAY AREA TECHNOLOGY SCHOOL**

THIS AGREEMENT ("Agreement") is made this 13th day of June, 2012, by and between the Oakland Unified School District, a public school district organized and existing under the laws of the State of California ("District") and Bay Area Technology School, a California public charter school ("Charter School"). The District and the Charter School are collectively referred to as "the parties."

RECITALS

WHEREAS, the Charter School is a non-profit public benefit corporation that is operating a charter authorized by the District;

WHEREAS, pursuant to the requirements of California Education Code section 47614 and its implementing regulations (also known as "Proposition 39"), the Charter School has made a written request for facilities for the 2012-2013 school year, a true and correct copy of which is attached as Exhibit A and hereby incorporated by reference; and

WHEREAS, pursuant to the requirements of Proposition 39 and its implementing regulations the District Board of Education has made a written offer to provide the Charter School with facilities for its in-district students, a true and correct copy of which is attached as Exhibit B and hereby incorporated by reference, and the Charter School has accepted the terms of that offer; and

WHEREAS, the parties desire to set forth the terms and conditions pursuant to which the Charter School will occupy classrooms and use facilities (the "Dedicated Space") at the District's King Estates Campus (the "Site"), located at 8251 Fontaine Street, sharing the Site with the District's Rudsdale, Sojourner Truth Independent Study, and Advance Path programs (the "District School"), commencing with the 2012-2013 school year. See facilities offer, Exhibit B, for a detailed description of the Dedicated Space.

NOW THEREFORE, in consideration of the covenants and agreements hereinafter set forth, the parties agree as follows:

Section 1. Use of Dedicated Space.

The District agrees to allow the Charter School exclusive use of the Dedicated Space (see Exhibit B), for the sole purpose of operating the Charter School educational program in accordance with the Charter School's charter. The Charter School's right to exclusive use of the Dedicated Space shall commence on July 1, 2012 and shall expire on June 30, 2013. Upon the termination of this Agreement, the right to exclusive use and occupation of the Dedicated Space and the facilities and equipment



OFFICE OF CHARTER SCHOOLS

thereon shall revert to the District, subject to the parties' negotiation of a successor Agreement, if necessary, containing the terms of the District's provision of facilities to the Charter School in accordance with the provisions of Proposition 39. As titleholder to the Dedicated Space and the facilities and equipment located thereon, the District reserves the right at the termination of this Agreement to recoup the full rights and benefits of such ownership, including, but not limited to, use of such Dedicated Space, facilities and equipment for District services.

The Charter School shall otherwise have full and exclusive use of the Dedicated Space. The Charter School shall comply with District policies regarding the operations and maintenance of the facilities, furnishings, and equipment.

Although the Charter School shall have the exclusive use of the Dedicated Space, District with the prior consent of Charter School, may agree to make the Dedicated Space available to members of the community in accordance with the provisions of the Civic Center Act (Education Code section 38131et seq.) If Charter School authorizes access to the Dedicated Space pursuant to the Civic Center Act, Charter School assumes the risk of loss or damage to property as a result of that access.

For purposes of compliance with the Civil Center Act with respect to the Dedicated Space only, the governing body of Charter School shall hold the same powers and obligations applicable to School District Boards of Trustees under Education Code sections 38130-38139 and shall also follow District Board Policy and Administrative Regulations in making use of the facilities accessible to members of the community.

Pursuant to the requirements of Proposition 39, the allocation of space as set forth in this Section is based upon an assumption of 249 in-district classroom ADA for the 2012-2013 school year. Future requests for additional facilities based on enrollment increases may be made in the manner specified in Section 11969.9 of the Proposition 39 regulations (Cal. Code Regs., Tit. 5, § 11969.9.)

The parties agree that the provision of facilities pursuant to this Agreement constitutes full and complete satisfaction of the District's obligation to provide facilities to Charter School under Proposition 39 for the 2012-2013 school year.

Section 2. Shared Space.

The District hereby grants to the Charter School the right to joint use of the following "Shared Space" solely for the purposes set forth in the Charter School's charter and on the terms and conditions set forth herein:

BATHROOMS: The Charter School students and staff shall have equal access to bathrooms in the shared space.



OFFICE OF CHARTER SCHOOLS

COMMON HALLWAYS: The District shall allow the Charter School students to use common hallways, to the extent necessary, for ingress and egress to the Charter School Dedicated Space described herein and to other shared spaces. Said use of common hallways by the Charter School students shall be pursuant to a set schedule and under the supervision of a Charter School employee.

PARKING: The District shall allow Charter School staff and faculty to access the employee parking at the Site on the same basis as that permitted to District employees. The District shall make parking available for Charter School staff and visitors on the same basis as that permitted to other schools on the Site. The District shall distribute the number of parking spaces equitably between the Charter School and the District School.

ATHLETIC FACILITIES: The District shall allow the Charter School to schedule supervised student use of the Site's gymnasium, locker rooms, and basketball/blacktop area so that the Charter School will provide its own Physical Education programs within the school day using these shared spaces. The Charter School shall coordinate with the Shared Site Committee to schedule its use of said athletic facilities for Physical Education. The athletic fields will be made available for use consistent with existing and future revised site-sharing agreements with the District School located on the site. Use of said fields will be in a manner defined by and distributed equally within the agreement.

DINING AREA/CAFETERIA/AUDITORIUM: The District shall allow the Charter School to schedule supervised student use of the Site's dining area and auditorium as outlined below.

COORDINATING SHARED USE: Charter School use of the parking area, shared bathrooms, athletic facilities, dining area/cafeteria, and such other common areas as may be located on the Site shall be coordinated through the Shared Site Committee. A clear and reasonable process shall be developed and adopted prior to the start of school in August 2012. The principal of the District School at the Site and principal of the Charter School may also, at their discretion, jointly refer other matters of shared site operations of the schools to the Shared Site Committee. The District shall provide the Charter School with appropriate keys to access shared space no fewer than ten (10) days prior to the start of school in August 2012, or seven (7) days prior if the District has good cause for delay. The Charter School will notify the Office of Charter Schools in writing by August 15, 2012 of any concerns regarding either access to keys or coordination of use for the shared space.

STUDENT DISCIPLINE: The principal of the District School at the Site and principal of the Charter School will collaborate to resolve any student disciplinary issues that involve students and/or property of both the Charter School and other District programs. The District shall otherwise have no responsibility as it relates to student discipline of Charter School students.

BELL SCHEDULE/ALARMS/ANNOUNCEMENTS: It is recognized that the Charter School may have a separate bell schedule from the District's programs. If deemed feasible, the dedicated space will have a separate intercom and bell system. If not feasible, the principal of the Charter School and the



principal of the District School shall collaborate in the development of a plan for modification of the intercom and bell system.

Section 3. Emergency Procedures for Shared Sites.

The principal of the Charter School and the principal of the District School shall immediately inform one another or their designees of any health and/or safety emergency as they relate to the safety of the schools on Site. This includes reports of any serious incident that takes place on the Site where the police, fire department, or paramedics are involved, including, but not limited to, incidents of physical or sexual abuse, bomb threats, weapons on the school Site, and the sale of narcotics on the school Site. Charter School staff, faculty, and students shall cooperate with, and participate in, any lockdowns or exigent security procedures required by the District at the Site.

The Charter School will be notified two operating days in advance of scheduled fire drills and emergency drills on the Site which may disrupt the Charter School and its operations. The Charter School will provide notification two operating days in advance to the District School of scheduled fire drills and emergency drills on the Site which may disrupt the District School and its operations.

Fire and other security and emergency alarm testing will be limited to after-school hours or non-teaching/training days. The principal of the Charter School and the principal of the District School shall meet in September to identify appropriate dates and times through the year for these tests.

Section 4. Facility & Amenities – Occupancy & Use.

FURNISHINGS AND EQUIPMENT: The District shall provide, in accordance with the Proposition 39 regulations, furnishings, and equipment at the Site. These furnishings and equipment shall remain the property of the District. The furnishings and equipment provided shall be equivalent to those furnishings and equipment provided in the comparison group of schools in accordance with 5 C.C.R. Section 11969.2. The District and the Charter School shall develop a mutually agreeable inventory of the furnishings and equipment that will be located at the Site.

SECURITY: The Dedicated Space shall be wired to the Site's alarm system. The Charter School shall be responsible for costs incurred due to false alarms and security breaches that are related to the Dedicated Space. The Charter School shall operate a closed campus and cooperate with the District on security issues. The Charter School may have a unique security code. If there is a fire at the property, the Charter School shall immediately notify the District but no later than within one business day.

SCHOOL SAFETY OFFICER: If School Safety Officer services are to be provided to the Charter School for the Dedicated Space, the District will be given the first opportunity to provide service. If the District deems it is unable to provide service, the Charter School may retain services from an external



OFFICE OF CHARTER SCHOOLS

provider. The Charter School will be responsible for costs of on-site security staff, whether provided by the District or an external provider.

EMERGENCY: In an emergency, including if the Space is destroyed or damaged in any material way, the District reserves the right to temporarily interrupt the Charter School's use of the Space, or any Site facilities or systems.

Section 5. Maintenance and Operations.

MAINTENANCE AND OPERATION DEFINED. Maintenance and Operations ("M&O") are broadly and generally defined as maintaining, repairing, and operating buildings (including the classrooms therein) and grounds efficiently on a regular basis, in a manner that promotes learning in a safe, clean, and healthy environment.

DISTRICT AND CHARTER SCHOOL RESPONSIBILITIES. The District and Charter School shall be responsible for performing M&O on the Site, including the Dedicated Space, to maintain a good, safe and sanitary condition, as described in the Charter School Facilities Guide attached hereto as Exhibit C. The District and the Charter School shall provide M&O services to the Site consistent with the District's M&O standards and policies and shall provide these services at a service level similar to that provided to the District public schools. Costs of M&O services provided by the District are included in the Pro Rata share which are paid by the Charter School and determined by calculating the actual square footage of the Dedicated Space and the percentage of Charter school's usage of the Shared Space, if applicable. If the Charter School requests any additional facilities-related services that are above and beyond the service level provided by the District public schools and which are not included in the M&O Pro-Rata Share but have been agreed to be provided by the District, costs of said services will be charged to the Charter School on a fee-for-service basis.

DEFERRED MAINTENANCE PLAN AND SERVICES. "Deferred Maintenance" shall mean facilities repair or replacement projects as described in Education Code section 17582(a) or additionally approved by the State Allocation Board; and further detailed by Office of Public School Construction Deferred Maintenance Program Handbook, as updated from time to time. Those projects include, but are not limited to, work necessary to restore or replace deteriorated or damaged building systems such as plumbing, heating, air conditioning, electrical, roofing, flooring, and wall systems. The exterior and interior painting of school buildings, asphalt paving, the inspection, sampling and analysis of building materials to determine the presence of asbestos-containing materials, the encapsulation or removal of asbestos-containing materials, the inspection, identification, sampling, and analysis of building materials to determine the presence of lead-containing materials, the control, management, and removal of lead-containing materials, or such other items as may be approved by the Board, to such condition that the school buildings may be effectively utilized for their designated purposes. The Parties acknowledge and agree that the District has certain obligations to deliver Deferred Maintenance to the Site in exchange for Charter School's Pro Rata Share Charge payments. The



OFFICE OF CHARTER SCHOOLS

District acknowledges and agrees that it will carry out its responsibilities in a good and workmanlike manner by properly qualified and licensed personnel and in accordance with all applicable laws and District policies. The District further acknowledges and agrees that all work it is obligated will be timely commenced and diligently prosecuted through completion.

Section 6. Reimbursement.

In the event that the space allocated to the Charter School is considered “over allocated” in accordance with 5 C.C.R. Section 11969.8, the Charter School shall follow the notification and reimbursement procedures outlined in 5 C.C.R. Section 11969.8.

Section 7. Modernization.

In the event that the District designates matching facilities funds for the facility and begins modernizing the facility, the District and the Charter School will meet to discuss the issue of modernization for the Site and impact on the Charter School’s occupancy.

Section 8. Fees and Payment.

DEFINITION OF PRO RATA SHARE CHARGE. The Parties acknowledge and agree that the District may not, pursuant to California law, charge Charter School rent in exchange for its use of the Dedicated Space; provided, however, that the District shall have the right to charge the Charter School an annual fee for use of the Dedicated Space consistent with Education Code section 47614(b) (the “Pro Rata Share Charge”). In exchange for payment of the Pro Rata Share Charge by Charter School, the District shall perform Deferred Maintenance upon the Dedicated Space for the benefit of Charter School. In charging the Pro Rata Share Charge the District shall not charge the higher oversight fee under Education Code section 47613.

CALCULATION OF PRO RATA SHARE CHARGE. The Pro Rata Share Charge shall be calculated in accordance with Title 5 CCR section 11969.7. When determining Charter School’s facilities costs, Charter School shall only be responsible for facilities payments for those types of facilities spaces used in the District’s calculation of the Pro Rata Share Charge. If the Charter School shares the Site, the Charter School shall only be charged the Pro Rata Share Charge on the Charter School Shared Space on a percentage of its usage of the shared premises. The Pro Rata Share Charge shall be determined by calculating the actual square footage of the Dedicated Space and the percentage of its usage of the Shared Space. Calculation of square footage and percentage of Shared Space is provided in Exhibit D hereto. The Charter School will not be charged a Pro Rata Share Charge for the Site that it does not use, but may be charged a proportional Pro Rata Share Charge for shared space needed for the overall operation of the campus as set forth in Title 5 CCR section 11969.7(c).



OFFICE OF CHARTER SCHOOLS

PAYMENT OF PRO RATA SHARE CHARGE. The District will invoice the Charter School and the Charter School will make installment payments on this invoiced amount payable to "Oakland Unified School District" and delivered to the District's Office of Charter Schools according to the following schedule:

- 25% by October 1;
- 25% by December 1;
- 25% by April 1;
- 25% by July 1.

The Charter School may choose to prepay any of the installment payments without incurring a prepayment penalty from the District. Charter School payments of undisputed amounts that are more than 30 calendar days late arriving at the District will incur a one (1%) percent per month interest charge on the balance. The District will deduct from subsequent transfer payments payable to the Charter School any undisputed scheduled payment amount due from this Agreement, plus interest charges, that is more than 60 calendar days past due.

The Fee does not include Site-specific costs which the school must include in its own budget. The Fee does not include, among other items, the cost of computers, computer lab, laptop carts, server equipment, internet service, phone service, audio-visual equipment, utilities, custodial, or campus security.

Either the Charter School or the District may call, at any time, for a meeting to discuss adjustments or reconciliation of these figures whenever there is reason to believe that these estimates do not reflect actual amounts owing.

If the Charter School disputes any fee or charge, it shall send written notification to the District. The Charter School has the right to submit the issue for resolution in accordance with the dispute resolution procedures outlined herein. Pending resolution of any dispute resolution procedures relating to the fee or charge, the Charter School shall only be required to continue paying any undisputed amount. Upon resolution of the dispute relating to the fee or charge, and based upon the ultimate resolution thereof, the Parties shall reconcile the amounts owed. The Charter School withholding disputed funds in not grounds for revocation.

FALSE FIRE AND INTRUSION ALARM RESPONSE ASSESSMENTS. The Charter School shall be solely responsible for the cost of all assessments, fines or penalties ("Assessments") imposed by the City of Oakland or its third party collection service for responding to false fire and intrusion alarms that are attributable to and /or located on the Dedicated Space. These false alarm response Assessments shall be presented to the Charter School upon receipt by the District of same from the City and shall be due and payable within thirty (30) calendar days from receipt.



Section 9. Utilities and Custodial Services.

The Charter School shall be solely responsible for the cost of all utilities used or consumed by the Charter School on the Site, including charges for electricity, natural gas, water, sewer, waste disposal, telephone and internet connectivity. With respect to internet connectivity, if feasible, the Charter School may assume use of the pre-existing T-1 line and transfer billing for the use of such line over to the Charter School. The Charter School shall obtain its own internet service and telephone provider and shall assume sole responsibility for upkeep and maintenance of all telephone systems, data lines, and related equipment, software and hardware. For costs of electricity, natural gas, water, sewer and waste disposal for the current year, the Charter School will be charged a fee equal to its percentage of the Site use times the total Site utilities costs billed to the District. The percentage of the Site use shall be calculated based on the square footage of the Designated Space plus the Charter School's proportional use of Shared Space, if applicable, as shown in Exhibit D. Such charges are to be paid according to the same billing cycle as for the pro rata fee.

Custodial service for the Site shall be provided by the District, unless otherwise agreed by the Parties. For the costs of custodial service, the Charter School will be charged a fee equal to its percentage of its Site use times the total charge for custodial services made to the Site through the District's budget system. The percentage of the Site use shall be calculated based on the proportion of classroom spaces dedicated to the Charter School's use, as shown in Exhibit D. Such charges are to be paid according to the same billing cycle as for the pro rata fee.

Section 10. Installation of Improvements.

IMPROVEMENTS: During the Term of this Agreement, the Charter School has no right to make alterations, additions, or improvements to the Site, which shall include modular classrooms, ("Improvements"), without the prior written consent of the District, and if required, the Division of the State Architect. The Charter School may submit a request to make Improvements to the Site and the District agrees to act upon a timely and complete request by the Charter School within thirty (30) days. If the District fails to provide a response to the Charter School within thirty (30) days regarding any such timely and complete request, the request shall be deemed approved. The District's approval of any Improvements, including the construction schedule, work hours, and modifications, shall be at District's sole and absolute discretion, and District may disapprove of such improvements without reason. Contractors retained by the Charter School with respect to the construction or installation of Improvements shall be fully licensed and bonded as required by law and must maintain levels of casualty, liability and workers' compensation insurance and performance and payment bonds consistent with District construction requirements. The construction or installation of Improvements shall be performed in a sound and workmanlike manner, in compliance with all laws applicable to charter schools. The District or the District's agent shall have a continuing right at all times during the period that Improvements are being constructed or installed to enter the premises and to inspect the



work, provided that such entries and inspections do not unreasonably interfere with the progress of the construction or interrupt instruction to students.

SIGNAGE: The Charter School may install signage at the Site including one sign at the Charter School's main entrance stating the charter school name and other pertinent information, a sign indicating the main office of the Charter School, and other directional signs as appropriate. The signage shall not require any Improvement to the Site in order to erect such signage. Such signage shall be in compliance with any District standards previously made available to Charter School and Charter School's receipt of any applicable permits and approvals required under any municipal or other governmental laws, ordinances, rules or regulations; provided, that in the event of any conflict between the District's standards and any applicable municipal or governmental permit and/or approval, the terms and conditions of the municipal or governmental permit and/or approval shall prevail. The Charter School may place additional signs on the property with prior District approval.

Section 11. Condition of Property.

The Charter School, at its expense, shall comply with all applicable laws, regulations, rules and orders with respect to its use and occupancy of the Dedicated Space, including, without limitation, those relating to health, safety, noise, environmental protection, waste disposal, and water and air quality. The Charter School shall not be responsible for any and all environmental conditions that existed prior to the Charter School's occupancy of the Dedicated Space. The District shall remain responsible for compliance with the ADA, FEHA, and other applicable building code standards regarding access for any existing compliance issue prior to the date of execution of this Agreement. The Charter School shall only assume responsibility for compliance with ADA and FEHA access rights to the extent of any modifications or improvement made by the Charter School.

Should any discharge, leakage, spillage, emission, or pollution of any type occur upon or from the Dedicated Space due to the Charter School's use and occupancy thereof, the Charter School, at its expense, shall be obligated to clean all the property affected, to the satisfaction of the District and any governmental agencies having jurisdiction over the Dedicated Space.

Section 12. Title to Property.

The parties acknowledge that title to the Dedicated Space is held by the District and shall remain in the District at all times.

Section 13. Fingerprinting.

The Charter School shall be responsible for ensuring compliance with all applicable fingerprinting and criminal background investigation requirements described in Education Code section 45125.1. Verification of compliance with the aforementioned fingerprinting and criminal background investigation requirements shall be provided in writing to the District prior to each individual's



commencement of employment or participation in any activity of the Charter School on the Dedicated Space and prior to permitting contact with District pupils.

Section 14. Insurance.

CHARTER SCHOOL INSURANCE. Charter School, at Charter School's sole cost and expense, shall both obtain and keep in full force and effect, beginning on the commencement date and continuing until this Agreement terminates, the following insurance policies for the Site, or, in lieu of maintaining coverage through an insurance company, use a self-insurance mechanism that meets the following criteria:

(1) **Liability Insurance.** Commercial general liability insurance with respect to the Site and Dedicated Space, if any, and the operations of or on behalf of the Charter School in, on or about the Site, including but not limited to: bodily injury, product liability (if applicable), blanket contractual, broad form property damage liability coverage and host liquor liability in an amount not less than One Million Dollars (\$1,000,000) in the aggregate, and excess liability coverage on a basis consistent with coverage for schools of a type similar to the Charter School. The policy shall be endorsed to name the Oakland Unified School District and the Board of Education of the City of Oakland as named additional insured and shall provide specifically that any insurance carried by the District which may be applicable to any claims or loss shall be deemed excess and the Charter School's insurance primary, provided however, that District's insurance shall be primary for claims caused by the actions of third parties, except to the extent that the third party's actions arose as a result of the negligence, intentional disregard or malfeasance of the Charter School.

(2) **Property Insurance.** Property insurance against fire, vandalism, malicious mischief and such other additional perils as now are or hereafter may be included in a standard "All Risks" coverage, including sprinkler leakage, insuring all of the Charter School's trade fixtures, furnishings, equipment, stock, loss of income or extra expense, and other items of personal property ("Charter's Property") in an amount not less than eighty percent (80%) of fair market value.

(3) **Workers' Compensation, Employer Liability.** Workers' compensation insurance in accordance with provisions of the California Labor Code adequate to protect the charter school from claims that may arise from its operations pursuant to the Workers' Compensation Act.

(4) **Fidelity Bond.** Fidelity bond coverage for all of Charter School's employees and who handle, process, or otherwise have responsibility for Charter School's funds, supplies, equipment or other assets. Minimum amount of coverage shall be \$50,000 per occurrence, with no self-insurance retention.

INSURANCE POLICY CRITERIA. All policies of insurance required to be carried by Charter School shall be written by responsible insurance companies authorized to do business in the State of



OFFICE OF CHARTER SCHOOLS

California. Any such insurance required of the Charter School hereunder may be furnished by the Charter School under any blanket policy carried by it or under a separate policy therefor. A true and exact copy of each paid-up policy evidencing such insurance or a certificate of the insurer, certifying that such policy has been issued, providing the coverage required and containing the provisions specified herein, shall be delivered to the District prior to the date the Charter School is given the right to possession of the Site. In addition, the District and the Board of Education of the City of Oakland shall be named as an additional insured on the liability policies and a loss payee on the property coverages for the Site. The District may, at any time and from time to time, upon reasonable notice to the Charter School and at no cost to the Charter School, inspect and/or copy any and all insurance policies required hereunder, and in no event shall the then-limits of any policy be considered as limiting the liability of the Charter School under this Agreement.

FAILURE TO OBTAIN INSURANCE. If the Charter School fails to procure, maintain and/or pay for at the times and for the durations specified in this Agreement, the insurance required hereunder, or fails to carry insurance required by any applicable law, the District may (but without obligation to do so), and with concurrent notice to the Charter School, perform such obligations on behalf of the Charter School, and the cost thereof, together with interest thereon at the Interest Rate from the date of demand until paid, shall become due and payable as additional payment by Charter School to the District. Charter School shall reimburse the District for cost of the premiums paid by the District for the insurance carried by the District pursuant to the terms above.

DISTRICT INSURANCE. During the Term of this Agreement, the District shall maintain insurance or shall self-insure against claims for injuries to persons or damages to property (real and personal, including the structures on the Site and any District-owned personal property) in amounts equal to that which would be in place if the Site were occupied by another school of the District. For services provided by the District to the Charter School, the District shall maintain responsibility for these services and such services shall be covered by the District's self-insurance or any insurance that the District may maintain.

Section 15. Indemnification.

The Charter School shall indemnify, hold harmless, and defend the District, its trustees, officers, employees and agents against and from any and all claims, demands, actions, suits, losses, liability, expenses and costs for any injury, death or damage to any person or property occurring in, on or about the Site after District delivers possession of the Dedicated Space to the Charter School, arising from the Charter School's use of the Dedicated Space or from the conduct of its business or from any activity, work, or other things done, permitted or suffered by the Charter School in or about the Dedicated Space; provided, however, that the Charter School shall not have any obligation to indemnify, hold harmless or defend the District, its trustees, officers, employees and agents against and from any and all claims, demands, actions, suits, losses, liability, expenses and costs for any injury, death or damage to any person or property occurring in, on or about the Site after the District delivers possession of the



Dedicated Space to the Charter School, resulting from or arising out of the sole negligence or willful malfeasance of the District, its trustees, officers, employees and agents or any person or entity not subject to the Charter School's control and supervision.

The District shall indemnify, hold harmless, and defend the Charter School, its trustees, officers, employees and agents against and from any and all claims, demands, actions, suits, losses, liability, expenses and costs for any injury, death or damage to any person or property occurring in, on or about the Site after District delivers possession of the Dedicated Space to the Charter School, arising from the District's use of the Dedicated Space or from the conduct of its business or from any activity, work, or other things done, permitted or suffered by the District in or about the Dedicated Space; provided, however, that the District shall not have any obligation to indemnify, hold harmless or defend the Charter School, its trustees, officers, employees and agents against and from any and all claims, demands, actions, suits, losses, liability, expenses and costs for any injury, death or damage to any person or property occurring in, on or about the Site after the District delivers possession of the Dedicated Space to the Charter School, resulting from or arising out of the sole negligence or willful malfeasance of the Charter School, its trustees, officers, employees and agents or any person or entity not subject to the District's control and supervision.

Section 16. Access.

The District and its authorized representatives shall have the right, after forty-eight (48) hours prior written notice to the Charter School, to enter the Site during normal business hours for the purpose of inspection and audit ("Inspection"); or to perform Deferred Maintenance in or on the Site. Nothing in this section shall prevent the District from entering the Site to address an emergency upon the Site nor shall this provision restrict the District's authority to enter the Site without advanced notice to perform its general oversight responsibilities under the terms of Charter School's charter and applicable law. An "emergency" shall be defined to include circumstances that risk the health and safety of students, personnel or other persons on the Site, or circumstances that risk further imminent damage or destruction to the Site, or otherwise jeopardizes the operation of the Site including, but not limited to, the safety and sanitary condition of the Site.

Section 17. Surrender of Dedicated Space.

Upon the termination date or other termination of occupancy pursuant to this Agreement, the Charter School shall peaceably quit and surrender to the District the Dedicated Space together with any furniture and equipment owned by the District, and Charter School improvements and all alterations approved by the District, in good order and condition, except for normal wear and tear after the Charter School's having made the last necessary repair required on its part under this Agreement, and further except for any portion of the Dedicated Space condemned and any damage and destruction for which the Charter School is not responsible hereunder.



Section 18. Holding Over.

Charter School shall surrender possession of the Site immediately upon the expiration of the term or earlier termination of this Agreement. Charter School will not be permitted to hold over possession of the Site after such expiration or earlier termination of the Term without the express written consent of the District, which consent the District may withhold in its sole and absolute discretion. Any holdover by Charter School shall constitute a breach of this Agreement by Charter School entitling the District to pursue any and all remedies available at law and in equity, including without limitation consequential damages resulting therefrom. During any hold over period, Charter School shall: (i) not occupy and use the premises during the hold over period except to remove its personal property and Alterations as it has coordinated with District; and (ii) authorize District to charge the Charter School \$100 per day (or any portion thereof) on the sixth day of the hold over and said per day rate shall increase by 100% for each 15 day period thereafter; provided, however, that these hold over provisions shall not apply to those situations where Charter School previously made a timely and legally sufficient request under Prop. 39 for the school year to commence after the last day of the term of this Agreement, the District made a facilities offer and Charter School accepted, and there is a delay in the delivery of the facilities.

Section 19. Liens.

Charter School shall not suffer or permit any liens to stand against the Site, or any part thereof, by reason of any work, labor, services or materials done, supplied, or claimed to have been done or supplied. If as a result of work performed by or under the direction of the Charter School any such lien shall at any time be filed against the Site, the Charter School shall provide written notice thereof to the District as soon as notice of such lien or action comes to the knowledge of the Charter School. The Charter School shall cause the lien or action to be discharged of record within thirty (30) days after the date of the filing of same, either by payment, deposit or bond, unless a bond therefore is already in effect. Nothing in this Agreement shall be construed as consent or agreement by the District to subject its estate in the Site or any estate that may be construed in favor charter school under this agreement to liability under any mechanics' lien law or to any contractor or laborer for work performed.

If any such liens are not so discharged within thirty (30) days after the date of the filing of the same, the District, without waiving its rights and remedies based on such breach by the Charter School whose dealings gave rise to the lien and without releasing the Charter School from any of its obligations, cause such liens to be released by any reasonable means, including payment in satisfaction of the claim giving rise to such lien.



Section 20. Damage and Destruction.

NOTICE TO THE DISTRICT. Charter School shall provide written notice to the District immediately of any casualty that wholly or partially damages or destroys the Charter School Dedicated Space.

(1) If Charter School and the District determine that all or substantially all of the Charter School Dedicated Space are inaccessible or unusable by Charter School in a safe manner, then the parties may mutually agree to terminate this Use Agreement.

(2) If Charter School and the District determine that Charter School can safely continue its educational program from the Charter School Dedicated Space, Charter School may elect to continue the Use Agreement in effect; provided, that Charter School's Pro Rata Share Charge shall be adjusted proportionately for that portion of the Charter School Dedicated Space that Charter School cannot and relinquishes use of.

(3) Upon mutual agreement between the parties, Charter School may elect to pay the District for the full estimated cost and expense to repair such damage or destruction, or pay in accordance with a structured payment schedule agreed to by the District. If Charter School exercises such option, this Use Agreement shall continue in full force and effect but the Pro Rata Share Charge and all other charges, expenses and fees shall be proportionately reduced as provided above.

(4) If this Use Agreement is terminated as provided above, the District shall house Charter School's entire program that was conducted at the Charter School Premises in a single facility for the remainder of the Charter School's planned school year. If the District cannot provide Charter School with a single facility, the District shall provide Charter School with classrooms sufficient to house the Charter School's entire program that was conducted at the Charter School Premises across multiple facilities or by temporary use of DSA compliant modular classrooms, as permitted by law, either on the Site or at other District real property that the District deems appropriate; provided, that pursuant to Section 47614(b)(1) of the Education Code nothing herein shall obligate the District to expend unrestricted general fund revenues.

Section 21. EMINENT DOMAIN

TERMINATION OF USE AGREEMENT. This Use Agreement shall terminate if all of the Charter School Dedicated Space is permanently taken under the power of eminent domain. If only a part of the Charter School Dedicated Space is permanently taken under the power of eminent domain, the District or Charter School may elect to terminate this Use Agreement by providing sixty (60) days' written notice to the other party. In the event of a permanent partial taking which does not result in termination of this Use Agreement, the Pro Rata Share Charge shall be proportionately reduced based on the portion of the Charter School Dedicated Space rendered unusable, and the District shall restore



the Charter School Dedicated Space by constructing a demising wall deemed necessary by the District to separate the Charter School Dedicated Space from the portion permanently taken. In the event the District terminates this Use Agreement pursuant to this Section, the District shall make best efforts to house Charter School's entire program in a contiguous facility for the remainder of the Charter School's planned school year. If the District cannot house the Charter School's entire program in a single contiguous facility, the District shall make best efforts to provide Charter School with classrooms sufficient to house the Charter School's entire program across multiple facilities or by use of temporary modular classrooms.

ALLOCATION OF CONDEMNATION AWARD. In the event of a permanent condemnation or taking of all or part of the Site, the District shall be entitled to any and all awards which may be made in such taking or condemnation relating to all interests, including the fee title, to the Site. Nothing contained in this Article 15 shall be deemed to give the District any interest in or to require Charter School to assign to the District any separate award as designated by the condemning authority made to Charter School for (i) the taking of Charter School's personal property, (ii) interruption of or damage to Charter School's business, or (iii) amounts attributable to Charter School's relocation expenses.

TEMPORARY TAKING. No temporary taking of the Charter School Dedicated Space or any part of the Charter School Dedicated Space and/or of Charter School's rights to the Charter School Dedicated Space under this Use Agreement shall terminate this Use Agreement or give Charter School any right to any abatement of any payments owed to the District pursuant to this Use Agreement, provided that such temporary taking does not continue for more than five (5) consecutive days or a total of five (5) non-consecutive days in any thirty (30) day period. Any award made by reason of such temporary taking shall belong entirely to the District, except as to compensation for (i) the temporary taking of Charter School's personal property, (ii) interruption of or damage to Charter School's business, or (iii) amounts attributable to Charter School's temporary relocation expenses.

Section 22. Charter School's Default; District's Remedies.

CHARTER SCHOOL'S DEFAULT. The occurrence of any one of the following events shall be considered a default of this Agreement by Charter School:

(1) The failure of Charter School to pay any charges or fees due and payable hereunder; provided, however, that any such notice shall be in lieu of, and not in addition to, any notice required under Code of Civil Procedure section 1161, and such ten (10) day cure period shall run concurrently with any cure period required under California law, including Code of Civil Procedure section 1161;

(2) The failure of Charter School to observe or perform any of its covenants or obligations hereunder, which failure continues past the notice and cure period provided herein. The District shall provide Charter School with written notice of default and Charter School shall have ten (10) business days to provide a response to the District either evidencing compliance with the terms of



OFFICE OF CHARTER SCHOOLS

this Agreement or a plan to cure the default and a reasonable timeline acceptable by the District within which Charter School will diligently prosecute the same to completion. In no event shall such default continue for more than ninety (90) days after written notice thereof by the District to Charter School without prior written agreement by the District. Any such notice shall be in lieu of, and not in addition to, any notice required under Code of Civil Procedure section 1161; and such cure period shall run concurrently with any cure period required under California law, including Code of Civil Procedure section 1161;

(3) Charter School's abandonment of the Charter Schools Dedicated Space for a period of thirty (30) consecutive days, it being agreed that the fact that any of Charter School's property remains in the Charter Schools Dedicated Space shall not be evidence that Charter School has not vacated or abandoned the Charter Schools Dedicated Space; provided, however, any normal school holidays including summer and inter-term breaks shall not constitute abandonment of the Charter Schools Dedicated Space;

(4) The making by Charter School of any general assignment or general arrangement for the benefit of creditors; the filing by or against Charter School of a petition to have Charter School adjudged bankrupt or a petition for reorganization or arrangement under any law relation to bankruptcy (unless the same is dismissed within sixty (60) days); the appointment of a trustee or received to take possession of substantially all of the Charter School's assets located at the Charter Schools Dedicated Space, or of Charter School's interest in this Agreement, where possession is not restored to Charter School within thirty (30) days; or the attachment, execution or other judicial seizure of substantially all of Charter School's assets located at the Charter Schools Dedicated Space or of Charter School's interest in this Agreement, where such seizure is not discharged within thirty (30) days.

(5) The cessation of the Charter School's program after a revocation, nonrenewal or surrender of the charter to the granting agency. However, the Charter School shall not be in default of this Use Agreement until after the Charter School has exhausted all appeals subsequent to the revocation or nonrenewal of its charter.

DISTRICT'S REMEDIES. (1) In the event of any default by Charter School and if Charter School fails to cure such default within the time period specified in this Agreement after receipt of written notice from the District of such default, the District shall have the right, in addition to all other rights available to the District under this Agreement or now or later permitted by law or equity, to terminate this Agreement by providing Charter School with a ninety (90) day prior written notice of termination. Upon termination, the District may recover any damages proximately caused by Charter School's failure to perform under this Agreement, or which are likely in the ordinary course of business to be incurred, including any amount expended or to be expended by the District in an effort to mitigate damages, as well as any other damages which the District is entitled to recover under any statute now or later in effect.



(2) In accordance with Civil Code section 1951.4 (or any successor statute), Charter School acknowledges that in the event Charter School has breached this Agreement and abandoned the Site, this Agreement shall continue in effect for so long as the District does not terminate Charter School's right to possession, and the District may enforce all its rights and remedies under this Agreement, including the right to recover the Pro Rata Share Charge as it becomes due under this Agreement and the reasonable costs incurred to preserve the property. Acts of maintenance or preservation of the Charter School Dedicated Space or the appointment of a receiver upon initiative of the District to protect the District's interest under this Agreement shall not constitute a termination of Charter School's right to possession. In addition to its other rights under this Agreement, the District has the remedy described in Civil Code section 1951.4.

(3) In the event of any default by Charter School and if Charter School fails to cure such default within a the time period specified in this Agreement after receipt of written notice from the District of such default, the District shall also have the right, with or without terminating this Agreement, to enter the Charter School Premises or Charter School Shared Premises and remove all persons and personal property from the Site, such property being removed and stored in a public warehouse or elsewhere at Charter School's sole cost and expense. No removal by the District of any persons or property in the Site shall constitute an election to terminate this Agreement. Such an election to terminate may only be made by THE District in writing, or decreed by a court of competent jurisdiction. The District's right of entry shall include the right to remodel the Charter School Premises or Charter School Shared Premises and re-let the Charter School Premises or Charter School Shared Premises. Any payments made by Charter School or third party to whom the facilities are re-let shall be credited to the amounts owed by Charter School under this Agreement. No entry by the District shall prevent the District from later terminating this Agreement by written notice.

(4) If Charter School fails to perform any covenant or condition to be performed by Charter School within a the time period specified in this Agreement after Charter School received written notice of such failure from the District, the District may perform such covenant or condition at its option, after notice to Charter School. In the event of an Emergency, the District has the right to perform such activity to mitigate the impact of the Emergency. All reasonable costs incurred by the District in so performing shall be reimbursed to the District by Charter School in accordance with section 5.2 hereof. Any performance by the District of Charter School's obligations shall not waive or cure such default. All out-of-pocket, reasonable costs and expenses actually incurred by the District in collecting payments due, or enforcing the obligations of Charter School under this Use Agreement shall be paid by Charter School to the District.

(5) The rights and remedies of the District set forth herein are not exclusive, and the District may exercise any other right or remedy now or later available to it under this Agreement, at law or in equity.



Section 23. The District's Default; Charter School's Remedies.

DISTRICT'S DEFAULT. The District shall be considered in default of this Agreement for failure by the District to observe or perform any of its covenants or obligations hereunder which continue beyond the notice and cure period provided herein (except in the event of an emergency, in which case the District shall perform its obligations immediately). Charter School shall provide the District with written notice of default and the District shall have ten (10) business days to provide a response to Charter School either evidencing compliance with the terms of this Agreement or a plan to cure the default and a reasonable timeline acceptable to Charter School within which the District will diligently prosecute the same to completion. In no event shall such default continue for more than ninety (90) days after written notice thereof by Charter School without prior written agreement by Charter School.

CHARTER SCHOOL'S REMEDIES. If the District fails to perform any covenant or condition to be performed by the District within the time period specified above, after the District received written notice of such failure from Charter School, Charter School shall have the right to withhold payment as its remedy for the District non-performance. In the event of an Emergency, Charter School has the right to perform such activity to mitigate the impact of the Emergency. All out-of-pocket, reasonable costs and expenses actually incurred by Charter School as a result of the District's failure to perform under this Use Agreement, in collecting payments due, or enforcing the obligations the District under this Use Agreement shall be paid by the District to Charter School within thirty (30) days of written demand therefor, or applied as a credit against the Pro Rate Charge.

The rights and remedies of Charter School set forth herein are not exclusive, and Charter School may exercise any other right or remedy now or later available to it under this Agreement, at law or in equity.

Section 24. Capacity to Sign.

All parties represent and warrant that they possess all necessary capacity and authority to sign and enter into this Agreement. Each individual signing this Agreement for a party which is a public agency, a corporation, a partnership, a limited liability company, or other legal entity, or signing under a power of attorney or as a trustee, guardian, conservator, or in any other legal capacity, represents and warrants that he or she has the necessary capacity and authority to act for, sign, and bind the respective entity or principal on whose behalf he or she is signing.

Section 25. Notice.

Any notice required or permitted to be given under this Agreement shall be deemed to have been given, served and received if given in writing and personally delivered or either deposited in the United States mail, registered or certified mail, postage prepaid, return receipt required, or sent by overnight delivery service or facsimile transmission, addressed as follows:



OFFICE OF CHARTER SCHOOLS

If to the District: Office of Charter Schools
Tilden School, Room 11
4551 Steele Street
Oakland, CA 94619
Attn: Coordinator

If to the School: Bay Area Technology School
8251 Fontaine Street
Oakland, CA 94605
Attn: School Director

Any notice personally given or sent by facsimile transmission shall be effective upon receipt. Any notice sent by overnight delivery service shall be effective the business day next following delivery thereof to the overnight delivery service. Any notice given by mail shall be effective three (3) days after deposit in the United States mail.

Section 26. Dispute Resolution.

Notwithstanding anything in this Agreement to the contrary, disputes between Charter School and the District regarding this Agreement, including, the alleged violation, misinterpretation, or misapplication of this Agreement, Proposition 39, or State Regulations shall be resolved using the dispute resolution process identified below.

The party initiating the dispute resolution process shall prepare and send to the other party a notice of dispute that shall include the following information: (1) the name, addresses and phone numbers of designated representatives of the party (the designated representatives must be an employees(s) of Charter School or the District); (2) a statement of the facts of the dispute, including information regarding the parties attempts to resolve the dispute; (3) the specific sections of the Agreement that are in dispute; and (4) the specific resolution sought by the party. Within ten (10) business days from receipt of the notice of dispute the representatives from Charter School shall meet with representatives from the District in an informal setting to try to resolve the dispute.

If the informal meeting fails to resolve the dispute the party initiating the dispute resolution process shall notify the other party (the responding party) in writing that it intends to proceed to mediation of the dispute and shall request the State Mediation and Conciliation Service to appoint a mediator within ten (10) business days to assist the parties in resolving the dispute (if the State Mediation and Conciliation Service ("SMCS") is unable or refuses to provide a mediator the parties shall mutually agree upon a mediator with fifteen (15) days from notice that SMCS will be unable to provide a mediator). The initiating party shall request appointment of a mediator who is available to meet as soon as possible but not later than 30 calendar days after receipt of the request for



appointment. The party initiating the dispute shall forward a copy of the notice of the dispute to the appointed mediator. The responding party shall file a written response with the mediator and serve a copy on the initiating party within seven business days of the first scheduled mediation. The mediation procedure shall be entirely informal in nature; however, copies of exhibits upon which either party bases its case shall be shared with the other party in advance of the mediation. The relevant facts should be elicited in a narrative fashion to the extent possible, rather than through examination and cross examination of witnesses. The rules of evidence will not apply and no record of the proceedings will be made. If an agreement is reached, the agreement shall be reduced to writing and shall be signed by the District and Charter School.

Either party may seek equitable or injunctive relief prior to the mediation to preserve the status quo or prevent irreparable injury pending the completion of that process. Except for such an action to obtain equitable relief, neither party may commence a civil action with respect to the matters submitted to mediation until after the completion of the initial mediation session, or 45 calendar days after the date of filing the written request for mediation, whichever occurs first. Mediation may continue after the commencement of a civil action, if the parties so desire.

Section 27. Subcontract and Assignment.

Neither party shall assign its rights, duties or privileges under this Agreement, nor shall a party attempt to confer any of its rights, duties or privileges under this Agreement (including that of sublease) on any third party, without the written consent of the other party.

Section 28. Independent Status.

This Agreement is by and between two independent entities and is not intended to and shall not be construed to create the relationship of agent, servant, employee, partnership, joint venture, or association.

Section 29. Entire Agreement of Parties.

This Agreement constitutes the entire agreement between the parties and supersedes all prior discussions, negotiations and agreements, whether oral or written. This Agreement may be amended or modified only by a written instrument executed by the parties.

Section 30. California Law.

This Agreement shall be governed by and the rights, duties and obligations of the parties shall be determined and enforced in accordance with the laws of the State of California. The parties further agree that any action or proceeding brought to enforce the terms and conditions of this Agreement shall be maintained in Alameda County, California.



Section 31. Attorneys' Fees.

If either party files any action or brings any proceedings against the other arising out of this Agreement, the prevailing party shall be entitled to recover, in addition to its costs of suit and damages, reasonable attorneys' fees to be fixed by the court. The "prevailing party" shall be the party who is entitled to recover its costs of suit, whether or not suit proceeds to final judgment. No sum for attorneys' fees shall be counted in calculating the amount of a judgment for purposes of determining whether a party is entitled to its costs or attorneys' fees.

Section 32. Waiver.

The waiver by any party of any breach of any term, covenant, or condition herein contained shall not be deemed to be a waiver of such term, covenant, condition, or any subsequent breach of the same or any other term, covenant, or condition herein contained.

Section 33. Successors and Assigns.

This Agreement shall be binding upon and inure to the benefit of the parties hereto and their respective heirs, legal representatives, successors, and assigns.

Section 34. Modifications.

Modifications of this Agreement may be made by mutual written agreement at any time and must express intent to modify this Agreement. Any modification of this agreement must be in writing and executed by duly authorized representatives of both parties.

Section 35. Force Majeure.

Whenever either party hereto shall be required by the terms of this Agreement or by law to perform any contract, act, work, construction, labor or services, or to perform and comply with any laws, rules, orders, ordinances, regulations or zoning regulations, said party shall not be deemed to be in default herein and the other party shall not enforce or exercise any of its rights under this Agreement, if and so long as nonperformance or default herein shall be directly caused by strikes, non-availability of materials, war or national defense preemptions or civil disobedience, governmental restrictions, alien invasion, or other similar causes beyond the reasonable control of the non-performing party.

Section 36. Counterparts.



OFFICE OF CHARTER SCHOOLS

This Agreement and all amendments and supplements to it may be executed in counterparts, and all counterparts together shall be construed as one document.

Section 37. Captions.

The captions contained in this Agreement are for convenience only and shall not in any way affect the meaning or interpretation hereof nor serve as evidence of the interpretation hereof, or of the intention of the parties hereto.

Section 38. Construction.

Nothing in this Agreement shall affect the number of positions held by or reduce the amount of work performed by District employees covered by a collective bargaining agreement with the District.

Section 39. Severability.

Should any provision of this Agreement be determined to be invalid, illegal or unenforceable in any respect, such provision shall be severed and the remaining provisions shall continue as valid, legal and enforceable.

Section 40. Incorporation of Recitals and Exhibits.

The Recitals and each exhibit attached hereto are incorporated herein by reference.

IN WITNESS WHEREOF, the parties hereto have executed this Agreement on the date first above written.

OAKLAND UNIFIED SCHOOL DISTRICT



Jody London, President, Board of Education



Date



Edgar Rakestraw, Jr., Secretary, Board of Education

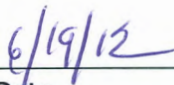

Date



OFFICE OF CHARTER SCHOOLS

APPROVED AS TO FORM:

[Signature]
Cate Boskoff, OUSD Facility Counsel
General Counsel

6/19/12
Date

CHARTER SCHOOL

By: HAYRI HATIPOGLU [Signature]

Date: 06/11/2012

Title: Principal of Bay Area Technology School

OUSD or the District verifies that the Contractor does not appear on the Excluded Parties List at www.epls.gov/epls/search.do

File ID Number: 12-1568
Introduction Date: 6-13-12
Enactment Number: 12-1611
Enactment Date: 6-13-12
By: [Signature]

Exhibit A: Charter School Proposition 39 Facilities Request



REQUEST FOR FACILITIES FOR THE 2012-2013 SCHOOL YEAR UNDER EDUCATION CODE §47614 (Proposition 39)

- Facilities request will only be accepted if submitted on this form.¹
- Include only information requested on this form; please refrain from including extraneous information.
- Facilities request must be received by 5:00 pm on Monday, November 1, 2011.
- A new or proposed new charter school may make a facilities request only if it submitted its charter petition on or before November 1 of the fiscal year preceding the year for which facilities are requested, and only if it receives approval of the petition before March 15 of the fiscal year preceding the year for which facilities are requested.

Charter School Name: Bay Area Technology School

Office Use Only

Contact Information

Date Submitted:

Initials:

Name: Hayri Hatipoglu

Phone: (510) 645-9932

Email: hhayri@baytechschool.org

Fax: (510) 645-9934

Mailing Address: 4521 Webster St. Oakland, CA 94609

Soft copy available at www.ousdcharters.net under the 'Accountability' tab.

1. Please complete the following tables:

Table 1: Total ADA Projections

A	B	C	D
Grade Level	Actual Total Prior Year (P-2)	Projected Total Current Year	Projected Total Request Year
6	33.4	41.4	47.5
7	24.5	40.7	47.5
8	39.6	32.1	47.5
9	30.4	36.8	42.8
10	18.1	31.9	42.8
11	16.1	19.4	28.5
12	14.6	17.6	23.7
Total	176.7	219.9	280.3

¹ 5 CCR § 11969.9(c)(3) School districts may require the charter school to submit its facilities request containing the information specified in paragraphs (1) and (2) on...another form specified by the school district.



Table 2: Total In-District ADA Projections

A	B	C	D
Grade Level	Actual Total Prior Year (P-2)	Projected Total Current Year	Projected Total Request Year
6	28.2	34.2	42.8
7	23.1	35.2	42.8
8	37.2	27.6	42.8
9	27.2	29.5	38.0
10	16.2	21.9	36.1
11	14.5	17.1	21.8
12	13.1	13.3	24.7
Total	159.5	178.8	249.0

The following is a list of the projected **in-District ADA** (from Table 2 above) by grade level and the District school the student would otherwise attend:

School Name/Grade	K	1	2	3	4	5	6	7	8	9	10	11	12
Bret Harte							6	3	2				
Claremont							6	8	7				
Edna Brewer								2					
Elmhurst							1		4				
Frick / MLA							9	3	3				
James Madison							1	1	1				
Roosevelt / Ascend							5	6	5				
Roots / Coliseum							3		1				
UFS/UPA/Ascend							5	7	2				
West Oakland								7	9				
Westlake							9	8	11				
Castlemont/Yes/Coliseum										6	5	4	7
Fremont/Life Acad.										5	4	4	6
McClaymonds HS										10	10	9	8
Oakland HS										2	5	1	4
Oakland Tech / Far West										11	12	1	3
Skyline HS										6	2	5	

2. Provide a description of the methodology used for the ADA estimates above. Title 5 CCR §11969.9, specify that a requesting charter school must determine a reasonable projection of the in-district average daily classroom attendance (ADA) for the applying school year.

In the last three school years (2008-2009, 2009-2010 and 2010-2011), BayTech school has shown strong growth in students numbers, growing from 163 to 229 students in just two years (an average growth of



OFFICE OF CHARTER SCHOOLS

18.5%). Its in-District ADA has also seen steady growth, including an increase of 23% between 2010-2011 and 2011-2012. As a result, BayTech is reasonably projecting that its ADA for the 2012-2013 educational year will increase.

BayTech has historically had an attendance rate/ADA percentage of 95%; BayTech therefore applied an attendance rate of 95% to its enrollment projections for the 2012-2013 school year in order to arrive at its projected ADA.

To date, BayTech has received its intent to re-enroll forms from 95% of its current students. In other words, almost every single student currently enrolled at BayTech will be returning for the 2012-2013 school year. Although we've received 95% of the Intent to Enroll forms of currently enrolled students, due to unexpected circumstances and situations which is typical in Oakland, such as; moving, legal custody issues, etc. it is a modest expectation that BayTech is projecting an %90 of retention rate for the upcoming year, nevertheless, we always have a waiting list to compensate for the transferring students. In addition, to date we have received 133 intent to enroll forms from new students, 58 of whom are prospective 6th grade students. The rest of the 133 students aforementioned which is equal to 75 is distributed among the other grade levels. Therefore, we are strongly expecting that we will easily reach the maximum number of student enrollment targets in each grade. Please see Tables 1,2 and 4.

BayTech has successfully fulfilled all the mandatory requirements to continue giving quality education to Oakland youth and recently was granted the WASC accreditation for the upcoming 6 years. Accordingly, BayTech is implementing a new vision, a new structure, a new approach and a broader outreach for the school through innovative technological programs and techniques such as CoolSIS (A Real Time Student Information System). In addition, BayTech won the silver medal in the famous ISWEEP Olympiads, last year, which also motivated our students and families which increased their commitment to our school.

Moreover, the huge turnout to our school events, programs and the wonderful positive feedback we are getting from our parents, friends and students also demonstrate that our school is well-regarded in the community, that we continue to gain new students through word of mouth. Please refer to our website: www.baytechschool.org ,or; please log onto the www.greatschools.org to view the fabulous comments about our school from a diverse range of people.

Please find the enrollment table below the ADA, retention rate and growth rate of BayTech for the last three years:

Table 4:

School Year	Enrollment	ADA %	ADA	Retention Rate	Grades
2009 / 2010	163	95%	154.8	-	6-11
2010 / 2011	186	95%	176.7	75%	6-12
2011 / 2012	229	96%	219.9	77%	6-12
2012 / 2013*	290	95%	275.5	90%	6-12



OFFICE OF CHARTER SCHOOLS

*BayTech's projection for 2012/2013

3. **Provide documentation of the number of in-district students meaningfully interested in attending the charter school, if relevant. Attach as APPENDIX 1.** *Title 5 CCR §11969.9(c)(1)(B)(C) state that the annual request must include a description of the methodology used in making the ADA projections and if relevant, documentation of the number of in-district students meaningfully interested in attending the charter school.*

Please see attached APPENDIX 1.

4. **Provide description of the district school site and/or general geographic area in which the charter school wishes to locate.**

BayTech currently shares its District campus with the International High School. BayTech is allocated 13 rooms; one of which is utilized as BayTech's front office (discipline coordinator, dean of academics, secretary and our music teacher all share this room) and the other is utilized as BayTech's administrative space (executive director, the principal, college counselor and after school coordinator/department head all share this one office). The other eleven rooms are utilized as classrooms for 12 classes, two classes per grade for 6th, 7th, 8th, 9th and 10th Grades, one class per grade for 11th and 12th Grades. However, because there are 12 classes and only 11 rooms (one of which is the computer lab) BayTech was forced to improvise by having combined classes/lessons. Furthermore, BayTech currently does not have a staff room. Some of our staff has no room to stay during what maybe their only prep time for the day, which creates inconveniences for our staff, students and administration on a regular basis. Unfortunately, there is not enough space to accommodate BayTech's program, which makes teaching very challenging for our teachers and learning very challenging for our students. In order to fully operate its program, BayTech needs a minimum of 12 regular teaching stations, one computer lab, one science lab, as well as (at least) an additional space for its offices.

Over the years, BayTech has contributed substantial time and has spent a lot of its own money (over \$80,000) to improve and upgrade its facilities so that the facilities can meet the challenging educational demands of its students. While BayTech is committed to continuing to upgrade, innovate, improve and develop the facilities, equipments, and furnishings which the District has provided to it, BayTech cannot continue to do this work singlehandedly, and requests the District's help in ensuring that the facilities BayTech occupies are reasonably equivalent to the facilities of the comparison schools. In specific, BayTech needs the District to do timely repairs and maintenance as most of the time it takes a few weeks for the district to attend to the work. Thus, the automatic AC systems in the classrooms malfunction occasionally. Hence, we would like the district to also oversee this.

BayTech requests that OUSD keeps the school in its current location for next year (2012-2013) as its teachers, students and parents love it and they all view it as their second home. Nonetheless, BayTech urgently needs two portables for additional classrooms, and another designated room for a staffroom. If



OFFICE OF CHARTER SCHOOLS

the district is on board , we have enough space for this new portable near portable #4 which is currently used as our only administration office.

5. Provide information on the charter school's educational program that is relevant to the assignment of facilities.

BayTech's mission statement concisely reads:

- * To be an educated, responsible citizen; working in a multicultural community
- * A curriculum based on Math, science and technology
- * To be ahead of or in line with the modern and global environment
- * To provide a healthy mind and body with a disciplined approach

Thus, BayTech's mission statement, and the District's obligations under Proposition 39, require that BayTech is provided with adequate facilities and resources. In other words, in order to implement our mission successfully, BayTech needs better facilities, greater space, and suitable equipment and technology. As a charter school, BayTech tries to accommodate the needs of all of its students and improve student performances, by providing tutoring for low-performing students, ESL, after school activities, clubs, weekend tutorials, homework time, SSR, etc..

In order to provide this aspect of our educational program, and in order for the District to meet its obligations under Proposition 39, the facility allocated to the Charter School must provide the following:

- (1) BayTech needs 12 classrooms, 1 computer lab, 1 Science Lab, 3 offices (one main office, one administrative room and one staffroom) to satisfactorily carry out its educational program.
- (2) A fully furnished and equipped cafeteria in order to utilize the National School Lunch Program for qualified students. (BayTech serves an average of 75% free and reduced lunch eligible students in its operation)
- (3) Fully furnished and equipped science laboratory space reasonably equivalent to that enjoyed by the district students in the comparison schools (please note that this is already required pursuant to 5 CCR 11969.3(b) and (c) but the district has not provided these spaces to BayTech in the past).
- (4) At least one classroom for performing arts/music instruction, as well as performance space such as an auditorium (please note that this is already required pursuant to 5 CCR 11969.3(b) and (c) but the district has not provided these spaces to BayTech in the past).
- (5) Physical education instruction facilities, including but not limited to athletic field space, gymnasium space, locker room space, and playground space (please note that this is already required pursuant to 5 CCR 11969.3(b) and (c)).
- (6) Access to the Charter School's entire facility for the entire school year, including the summer months.

In addition, if the District's comparison schools include any other facilities not identified here, the District must also allocate a reasonably equivalent amount of these facilities.



6. Include a copy of the charter school's 2012-2013 operational calendar. Attach as APPENDIX 2.

Please see attached APPENDIX 2.



BAY AREA TECHNOLOGY SCHOOL

Quality is everyone's responsibility



Academic Calendar 2012-2013

July '12						
M	Tu	W	Th	F	Sa	Su
						1
2	3	4	5	6	7	8
9	10	11	12	13	14	15
16	17	18	19	20	21	22
23	24	25	26	27	28	29
30	31					

August '12						
M	Tu	W	Th	F	Sa	Su
		1	2	3	4	5
6	7	8	9	10	11	12
13	14	15	16	17	18	19
20	21	22	23	24	25	26
27	28	29	30	31		

September '12						
M	Tu	W	Th	F	Sa	Su
					1	2
3	4	5	6	7	8	9
10	11	12	13	14	15	16
17	18	19	20	21	22	23
24	25	26	27	28	29	30

October '12						
M	Tu	W	Th	F	Sa	Su
1	2	3	4	5	6	7
8	9	10	11	12	13	14
15	16	17	18	19	20	21
22	23	24	25	26	27	28
29	30	31				

November '12						
M	Tu	W	Th	F	Sa	Su
			1	2	3	4
5	6	7	8	9	10	11
12	13	14	15	16	17	18
19	20	21	22	23	24	25
26	27	28	29	30		

December '12						
M	Tu	W	Th	F	Sa	Su
					1	2
3	4	5	6	7	8	9
10	11	12	13	14	15	16
17	18	19	20	21	22	23
24	25	26	27	28	29	30
31						

January '13						
M	Tu	W	Th	F	Sa	Su
	1	2	3	4	5	6
7	8	9	10	11	12	13
14	15	16	17	18	19	20
21	22	23	24	25	26	27
28	29	30	31			

February '13						
M	Tu	W	Th	F	Sa	Su
				1	2	3
4	5	6	7	8	9	10
11	12	13	14	15	16	17
18	19	20	21	22	23	24
25	26	27	28			

March '13						
M	Tu	W	Th	F	Sa	Su
				1	2	3
4	5	6	7	8	9	10
11	12	13	14	15	16	17
18	19	20	21	22	23	24
25	26	27	28	29	30	31

April '13						
M	Tu	W	Th	F	Sa	Su
1	2	3	4	5	6	7
8	9	10	11	12	13	14
15	16	17	18	19	20	21
22	23	24	25	26	27	28
29	30					

May '13						
M	Tu	W	Th	F	Sa	Su
		1	2	3	4	5
6	7	8	9	10	11	12
13	14	15	16	17	18	19
20	21	22	23	24	25	26
27	28	29	30	31		

June '13						
M	Tu	W	Th	F	Sa	Su
					1	2
3	4	5	6	7	8	9
10	11	12	13	14	15	16
17	18	19	20	21	22	23
24	25	26	27	28	29	30

No School Days

- August '12
 - 1-Aug Teacher In Service
 - 2-Aug Teacher In Service
 - 3-Aug Teacher In Service
 - 6-Aug Teacher In Service
 - 7-Aug Teacher In Service
 - 10-Aug Parent Orientation
 - 11-Aug Parent Orientation
- September '12
 - 3-Sep Labor Day
- October '12
 - 15-Oct Professional Development
- November '12
 - 11-Nov Veterans Day Observed
 - 22-Nov Thanksgiving
 - 23-Nov Thanksgiving
- December '12
 - 17-Dec Winter Break
 - 18-Dec Winter Break
 - 19-Dec Winter Break
 - 20-Dec Winter Break
 - 21-Dec Winter Break
 - 24-Dec Winter Break
 - 25-Dec Winter Break
 - 26-Dec Winter Break
 - 27-Dec Winter Break
 - 28-Dec Winter Break
 - 31-Dec Winter Break
- January '13
 - 1-Jan Winter Break
 - 2-Jan Winter Break
 - 3-Jan Winter Break
 - 4-Jan Winter Break
 - 18-Jan Professional Development
 - 21-Jan ML King Day
- February '13
 - 15-Feb Professional Development
 - 18-Feb President's Day
- March '13
 - 11-Mar Spring Break
 - 12-Mar Spring Break
 - 13-Mar Spring Break
 - 14-Mar Spring Break
 - 15-Mar Spring Break
- April '13
 - 1-Apr Professional Development

Important Days

- August '12
 - 14-Aug 1st Day of School
 - 20-Aug MAP I (1 Week)
 - 28-Aug Picture Day
- September '12
 - 20-Sep Back to School Night (6pm)
 - 28-Sep Picture Re-Take Day
- October '12
 - 2-Oct CAHSEE ELA 11th, 12th Grades
 - 3-Oct CAHSEE MATH 11th, 12th Grades
 - 17-Oct PSAT 9th, 10th, and 11th Grades
 - 27-Oct ACT Test
- November '12
 - 6-Nov CAHSEE ELA 10th Grades
 - 7-Nov CAHSEE MATH 10th Grades
- December '12
 - 10-Dec Fall Finals (3 Days)
 - 14-Dec End of 1st Semester
- January '13
 - 7-Jan MAP II (1 Week)
- March '13
 - 4-Mar MAP III (1 Week)
 - 16-Mar CHSPE Test Date
- April '13
 - 13-Apr ACT Test
 - 18-Apr STAR TEST (Tentative)
 - 19-Apr STAR TEST (Tentative)
 - 22-Apr STAR TEST (Tentative)
 - 23-Apr STAR TEST (Tentative)
 - 24-Apr STAR TEST (Tentative)
 - 25-Apr STAR TEST Make-Up (Tentative)
 - 26-Apr STAR TEST Make-Up (Tentative)
- May '13
 - 14-May CAHSEE ELA 11th, 12th Grades
 - 15-May CAHSEE MATH 11th, 12th Grades
 - 20-May Spring Finals (3 Days)
 - 23-May 8th Grade Promotion Ceremony
 - 24-May Graduation Ceremony
 - 24-May Last Day For Students
- TBA SAT Test
- TBA SAT Test
- TBA STAR Grade 7 Writing Test
- TBA AP US History (Tentative)
- TBA AP Biology (Tentative)
- TBA AP Computer Science (Tentative)
- TBA AP Eng Lang. and Comp (Tentat.)
- TBA AP World History (Tentative)

Purple & Blue : No School Days

Green: Important Days

Exhibit B: OUSD Final Proposition 39 Facilities Offer

OAKLAND UNIFIED SCHOOL DISTRICT
Office of the Superintendent

April 25, 2012

Legislative File

File ID No.: 12-0820

Introduction Date: 3/28/2012

Enactment No.: 12-1255

Enactment Date: 4-25-12

By: 

TO: Board of Education 

FROM: Anthony Smith, Ph.D., Superintendent
Gail Ann Greely, Coordinator, Office of Charter Schools

SUBJECT: Prop. 39 Final Facility Offer 2012-2013 School Year

ACTION REQUESTED:

Approve the proposed Final Facilities Offer to be made by the District to Bay Area Technology School under the Proposition 39 Statute, wherein charter schools are granted the right to request facilities allocations from the school district in which they reside commensurate with the in-district ADA of the charter school enrollment.

SUMMARY:

Following a period of preliminary facility offer considerations, as required under state statute, staff recommends the approval of the Final Facilities Offer under Proposition 39, as outlined in the attached resolution, with the specific facility space allocations included in the attached Final Facilities Offer Letter.

Each Proposition 39 application submitted pursuant to statute requirements was evaluated to determine the specific facilities needs under which the District is obligated to meet. To the extent possible, OUSD has attempted to match charter school facility requests with space available based on the compatibility of the following features:

- The quantity of classroom space requested and the excess classroom space available.
- The grades served by each program when programs are co-located.
- The school program and the site.
- The location requested and the location available.

Following a review of current projected use of District facilities for the academic school year 2012-2013, staff identified the facilities indicated in the attached resolution as the most appropriate and compliant facilities to commit as a Final Facilities Offer pursuant to the school's Proposition 39 facilities request. Statute requires that requesting charter schools receive Final Facility Use Offers by April 2, 2012 (April 1st being a Sunday) and in turn must respond to that offer no later than May 1, 2012. In this case, the District and the charter school have mutually agreed to an extension of the final offer deadline to April 25, 2012, with a response due no later than May 25, 2012. A declined offer finalizes the Proposition 39 Facilities Request process. Should a Final Facilities Offer be accepted, it will be contingent on the terms of the facility use agreement, as well as the expectations established for the equitable sharing of facilities, where applicable, between the school site administrators.

The facility use rate under which the Final Facilities Offer will be made is established at a rate to be \$2.95 per square foot, per year, based on an analysis by Facilities Counsel and the CFO as to the applicable costs associated with statute.

The calculation of square footage allocation to be offered is based on a division of the total facility square footage by a divisor equal to the percentage of total classrooms within the facility being allocated to the charter school. The calculation of teaching stations (classrooms) to be offered to the requesting charter school applies the statutory language where-in the determination must be made using "comparison schools" comprised of the *"school district-operated schools with similar grade levels that serve students living in the high school attendance area ... in which the largest number of students of the charter school reside."*

The attached resolution outlines the total square footage and teaching stations to be included in the Final Facilities Offer under Proposition 39. The attached Final Facilities Letter includes specific space identified for consideration by each requesting school within the statutory timeframe.

BACKGROUND:

Under the California Education Code Section 47614; *"Each school district shall make available, to each charter school operating in the school district, facilities sufficient for the charter school to accommodate all of the charter school's in-district students in conditions reasonably equivalent to those in which the students would have been accommodated if they were attending other public schools of the district."*

Under this statute, the District is obligated to provide facilities to requesting charter schools operating within Oakland Unified attendance boundaries. These facilities offers, if accepted, will be followed by the establishment of a Facility Use Agreement which will define the scope of the facility use terms. The period under which these facilities will be offered by use of the requesting charter school is for **one academic school year only: 2012-2013**. The requesting charter school may submit a subsequent Prop. 39 facilities request for the ensuing school years, pursuant to the requirements of the statute and applicable legislation, which will then be evaluated within the context of the District's continued capacity to provide such facilities.

RECOMMENDATION:

It is the recommendation of staff to approve the proposed Final Facilities Offer to Bay Area Technology School under Proposition 39 as outlined in attached resolution.



OAKLAND UNIFIED SCHOOL DISTRICT

Office of the Superintendent
1025 Second Avenue, Room 301
Oakland, CA 94606
Phone (510) 879-8200
Fax (510) 879-8300

RESOLUTION
OF THE
GOVERNING BOARD
OF THE
OAKLAND UNIFIED SCHOOL DISTRICT

Resolution No. 1112-0201

2012-2013 School Year Offer(s) of King Estates Site (In Part), a District Facility, To Bay Area Technology School, Pursuant to Requirements of Proposition 39

WHEREAS, Proposition 39 – School Facilities, adopted by California voters on November 7, 2000, requires a local K-12 school district under specified circumstances to make available District facilities to Charter Schools; and,

WHEREAS, the District has received such a request pursuant to statutory requirements from one or more Charter Schools for the 2012-2013 school year; and,

WHEREAS, District staff has evaluated the requests and has attempted to match charter school facility requirements with available space, if any, within the District; and,

WHEREAS, District staff specifically has attempted to match charter school facility requests with available space based on the compatibility of the following features:

- The quantity of classroom space statutorily required to be provided and the excess classroom space available;
- The grades served by each program when programs are co-located;
- The school program and the site; and,
- The location requested and the location available; and

WHEREAS, District staff based on the foregoing and a current projected use of District facilities for the 2012-2013 School Year, has identified facilities that are appropriate and compliant with the requirements of Proposition 39 to make available to Charter Schools; and,

WHEREAS, the District is presently required under statute to make such a Final Facility Offer not later than April 2, 2012 (April 1st being a Sunday); and,

WHEREAS, offers made under Proposition 39 must be responded to by the charter school within 30 calendar days of the date at which the offer is made, or no later than May 1, 2012; and,

WHEREAS, the District and the charter school mutually agreed to extend the timeline for the Final Facility Offer to April 25, 2012 and the date for a response to no later than May 25, 2012; and

WHEREAS, District staff has developed a preliminary Facility Use Agreement that will be required to come before the Governing Board of the District for final approval, should the Facility Offer be accepted by the charter school; and,

WHEREAS, the facility use rate associated with the facility offer proposed here-in considers all applicable costs that may be included in the pro rata facility use rate under statute, and has been reviewed by District legal counsel to ensure alignment with said statute; and,

WHEREAS, the Final Facility Offer detailed herein is for a period of one year only, the 2012-2013 School Year; and,

WHEREAS, the Final Facility Offer letter attached herein includes the following information, limited to those areas required under statute, per District counsel advice;

- The teaching and non-teaching space to be offered for exclusive use and teaching and non-teaching space to be shared
- The arrangements for shared space
- The in-District classroom ADA assumptions for the charter school
- Pro rata share amount and payment schedule; and,

NOW, THEREFORE, BE IT RESOLVED, the District hereby makes said offers, summarized herein, as follows for the 2012-2013 School Year to the Charter School named below:

<p>Bay Area Technology School, 6-12 (2012-13)</p>	<p><u>ENROLLMENT:</u> In-District ADA: 249 Total in-district enrollment based on most relevant attendance rate: 95.00%</p>	<p><u>RATIO:</u> Ratio applied to in-district enrollment based on an evaluation of equivalent facility allocation to comparison district school students: 20.13</p>	<p><u>TEACHING STATION ALLOCATION:</u> Total teaching station allocation: 12 teaching stations</p>
<p><u>FINAL FACILITIES OFFER:</u> King Estates (see map)</p> <ul style="list-style-type: none"> - 12 teaching stations identified within the attached map - 2 non-teaching stations identified within the attached map - Access to shared spaces as identified (cafeteria, gym, gym work-out rooms, yard and fields) 	<p><u>PRO RATA SHARE FACILITY USE RATE:</u> Total Square Footage of exclusive use and prorated shared use of the Facility space included in Final Offer:</p> <p>29,268 sq ft (calculated based on exclusive use and percentage of shared use space: includes 32% of cafeteria and gym, and exclusive use of space marked Unit C, 7 portable classrooms, and rooms 1, 2, 3, and 4 in Unit D)</p> <p>Annual Facility Use Rate \$2.95 per square foot, per year.</p>	<p><u>SHARED ACCESS TO SHARED SPACE:</u> Final Facilities Offer to include shared use of cafeteria, gymnasium, work-out/dance room, yard and fields commensurate with the percentage of total facility space allocated for exclusive use by the charter school (see map).</p>	

	Total Facility Use Rate pursuant to this offer: \$83,662.00	
--	---	--

BE IT FURTHER RESOLVED that any such offer accepted not later than May 25, 2012 by Charter School shall be formalized by a mutually approved Facility Use Agreement between the District and the Charter School.

I hereby certify that the foregoing is a full, true, and correct copy of a Resolution passed at a Regularly Scheduled Meeting of the Superintendent and/or Board of Education of the Oakland Unified School District on April 25, 2012.

Passed by the following vote:

AYES: David Kakishiba, Gary Yee, Christopher Dobbins, Noel Gallo,
Vice President Jumoke Hinton Hodge and President Jody London

NOES: Alice Spearman

ABSTAINED: None

ABSENT: None

I hereby certify that the foregoing is a full, true and correct copy of a Resolution adopted at a Regular Meeting of the Governing Board of the Oakland Unified School District held April 25, 2012.



Edgar Rakestraw, Jr.
Secretary, Board of Education

File ID Number: 12-0820
Introduction Date: 4-25-12
Enactment Number: 12-1255
Enactment Date: 4-25-12
By: dz

April 25, 2012

Hayri Hatipoglu
Bay Area Technology School
4521 Webster Street
Oakland, CA 94609

Certified Mail & Fax

**RE: Proposition 39 Final Facility Offer
King Estates – 8251 Fontaine Street**

Dear Hayri Hatipoglu:

On November 7, 2000, California voters passed Proposition 39. A portion of this initiative amended Education Code section 47614 to mandate that school districts make excess facility space available to in-district charter school students, if certain conditions are met, in a manner that is fair to all public school students. The California Department of Education has also promulgated implementing regulations, most of which took effect on August 29, 2002.

To the extent possible, Oakland Unified School District has attempted to match charter school facility requests with space available based on the compatibility of the following features:

- The quantity of classroom space requested and the excess classroom space available.
- The grades served by each program when programs are co-located.
- The school program and the site.
- The location requested and the location available.

On February 1, 2012, the District provided your charter school a Proposition 39 preliminary facility offer to occupy space for one year only at Santa Fe Elementary School, as required by the California Code of Regulations, Title 5. Education, Division 1. California Department of Education, Chapter 11. Special Programs, Subchapter 19, Charter Schools, Article 3. Facilities for Charter Schools, Section 11969.9 (5 CCR s 11969.9 Cal. Admin. Code Tit. 5, s 11969.9).

This letter constitutes a Final Offer of facility space as required by the California Code of Regulations, Title 5. Education, Division 1. California Department of Education, Chapter 11. Special Programs, Subchapter 19, Charter Schools, Article 3. Facilities for Charter Schools, Section 11969.9 (5 CCR §11969.9).

Response to Charter School Concerns or Counter-Proposal

As described in 5 CCR §11969.9(g), the charter school responded in writing to the District's preliminary facilities proposal. The District's response to the charter school's concerns and/or counter proposals is attached.

2012-2013 Proposition 39 Final Facility Offer

From Oakland Unified School District

To Bay Area Technology School

For the 2012-2013 School Year Only

- Exclusive use of 12 classrooms at King Estates, 8251 Fontaine Street (including specialized science, computer and music rooms)
- Exclusive use of 2 non-teaching space within King Estates, 8251 Fontaine Street
- Shared use of cafeteria, gym, gym work-out rooms, yard and fields.

This offer is based on an in-district classroom ADA assumption of 249 students in 6-12 at Bay Area Technology School.

The District and the charter school shall negotiate a Facilities Use Agreement regarding use of and payment for the space. The agreement shall contain: for shared space, the arrangements for sharing; specific location(s) of the space; all conditions pertaining to the space; the pro rata share amount; and the payment schedule. (A draft of a Facilities Use Agreement including these terms was provided with the preliminary offer.)

The space allocated by the school district will be furnished with desks and chairs, equipped with dry erase boards, and available for occupancy by the charter school ten days prior to the charter school's first day of instruction in 2012-2013 (may be reduced to seven days, for good cause).

The charter school must report actual ADA to the school district every time that the charter school reports ADA for apportionment purposes. The reports must include in-district and total ADA and in-district and total classroom ADA. The charter school must maintain records documenting the data contained in the reports. These records shall be available on request by the school district.

The charter school and the District may negotiate separate agreements and/or reimbursement arrangements for specific services not considered part of facilities costs as defined in Section 11969.7. Such services may include, but are not limited to, the use of additional space and operations, maintenance, and security services.

ANNUAL PRO RATA SHARE & PAY SCHEDULE

All charter schools that choose to accept the Proposition 39 offer to occupy District facilities will be charged a facilities use rate that represents the charter school's pro rata share of general fund

expenditures for the last fiscal year for costs for building and grounds deferred maintenance, as allowed by statute and regulations.

The charter school's annual rate includes the charter school's contribution for use of classrooms and administration space, shared access to special classrooms and non-classroom space. There may be additional pro rata charges for required services to the entire facility, such as custodial services, sewer charges, and gas, water and electricity. These terms and rates will be part of the final Facilities Use Agreement.

The charter school will be charged, at the actual cost, for any extra or extended services provided by OUSD to the charter school. The charter school will be responsible for acquiring its own basic and long distance telephone service and Internet connectivity. The charter school will not be part of Oakland Unified School District's e-mail network or its '879-xxxx' telephone system. This access will be separately acquired by the charter school after consulting with OUSD facility staff regarding its installation at the site.

The pro rata share amount that the charter school will pay for this space will be \$83,662.00.

The payment schedule for the pro rata share amount, which takes into account the timing of revenues from the state and from local property taxes, is as follows:

- 25% by October 1;
- 25% by December 1;
- 25% by April 1; and
- 25% by July 1.

RESPONSE

The charter school must notify the school district in writing whether or not it intends to occupy the offered space. This notification must occur no later than 5:00 p.m., Friday, May 25, 2012 or within 30 days after District notification, whichever is later. The charter school's notification can be withdrawn or modified before this deadline as the District and charter school negotiate terms of the Facilities Use Agreement. After the deadline, if the charter school has notified the District that it intends to occupy the offered space, the charter school is committed to paying the pro rata share amount as identified. If the charter school does not notify the District by this deadline that it intends to occupy the offered space, then the space shall remain available for school district programs and the charter school shall not be entitled to use facilities of the school district in 2012-2013.

Respond to this final facility offer by fax, mail, or personal delivery, to be **received by 5:00 p.m., Friday, May 25, 2012** at the following address:

Oakland Unified School District
Office of Charter Schools
Attention: Gail Greely

HAND DELIVERY:

Tilden School
4551 Steele Street, Rm. 11

FAX:

510-482-6774

EMAIL:

Gail.Greely@ousd.k12.ca.us

Oakland, CA 94619

Please do not contact the principal currently operating at the offered campus. Contact the Office of Charter Schools to schedule a meeting to discuss any terms and conditions that would apply to the specific District site offered. These specific terms and conditions will be included in the Facilities Use Agreement. If you would like to schedule another viewing the site or if you have any questions, please contact me at (510) 336-7571 or at Gail.Greely@ousd.k12.ca.us.

Sincerely,

Gail Ann Greely
Office of Charter Schools, Coordinator

Cc: Jacqueline Minor, OUSD General Counsel
Cate Boskoff, OUSD Facilities Counsel
Dr. Anthony Smith, Superintendent
Timothy White, Assistant Superintendent, Facilities, Planning & Management
Tadashi Nakadegawa, Director of Facilities Management
David Montes, Director of Quality Community Schools Development Group
Alison McDonald, Network Executive Officer

Enclosure: Plan of King Estates

**Proposition 39 Final Offer of Facilities
Response to Charter School Concerns and/or Counter Proposal/s
Bay Area Technology School**

Concern: Bay Tech would like to continue with the district lunch program, similar to the arrangement at its current location.

- At this time, there is no apparent obstacle to Bay Tech continuing its current agreement with OUSD's Nutritional Services. Bay Tech can contact Jennifer LeBarre, Director of Nutrition Services for more information.

Concern: Bay Tech asks how it will be provided with suitable furniture and equipment for its middle and high school students if located at an elementary school site.

- OUSD will meet its obligations under Proposition 39 to provide furniture and equipment comparable to that provided to district schools, using a variety of measures that could include designating furniture currently at the final offer site, moving furniture and equipment located at the current Bay Tech site, and/or selecting furniture and equipment from District surplus.

Concern: Bay Tech requests the option to provide its own custodial services.

- Because the final offer site will be shared with another District school, use of District custodial services is generally required. Specific arrangements or exceptions for custodial service for Bay Tech at the King Estates site can be addressed in the Facilities Use Agreement.

Concern: Bay Tech requests clarification of the calculation of the square footage upon which the pro rata charge facilities fee is based, particularly with respect to shared space.

- For the final offer, the square footage is the total of the square footage shown on the site plans (included with the offer) for each of the buildings offered to Bay Tech exclusively, plus a portion of the square footage of shared building space. The spaces offered to Bay Tech exclusively are (as designated on the attached site plans) Unit C, all portable classrooms (7) behind Unit C, plus rooms designated as 1, 2, 3, and 4 in Unit D. The shared space is calculated as 32% of the square footage of Units E (cafeteria/multi-purpose room) and F (gymnasium). The share was determined to be 32% based on the proportion of classrooms offered to Bay Tech (12 classrooms of 37 total on campus).

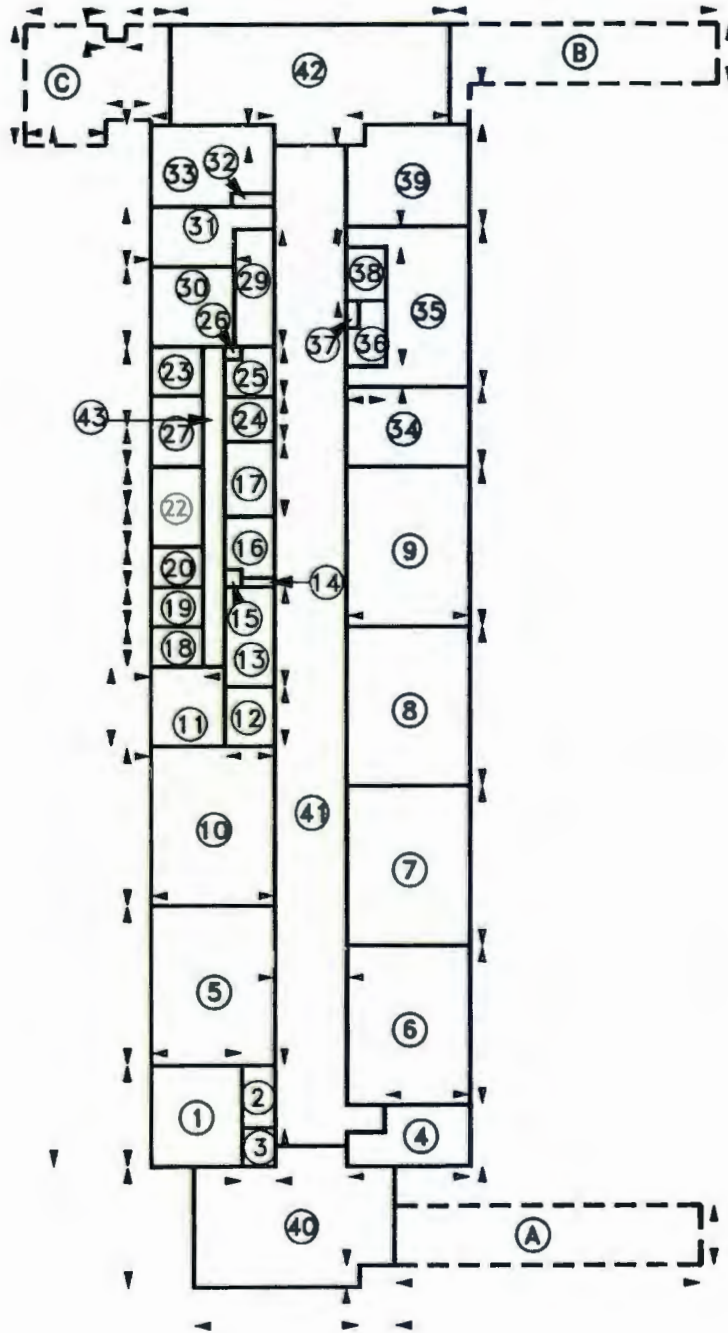

Not drawn to scale

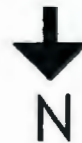

216 - King Estates Middle School - Unit A

8251 Fontaine Street - Oakland, CA 94605-4109

THINK

mkfnd 41 402 0688

2011



OAKLAND UNIFIED
SCHOOL DISTRICT

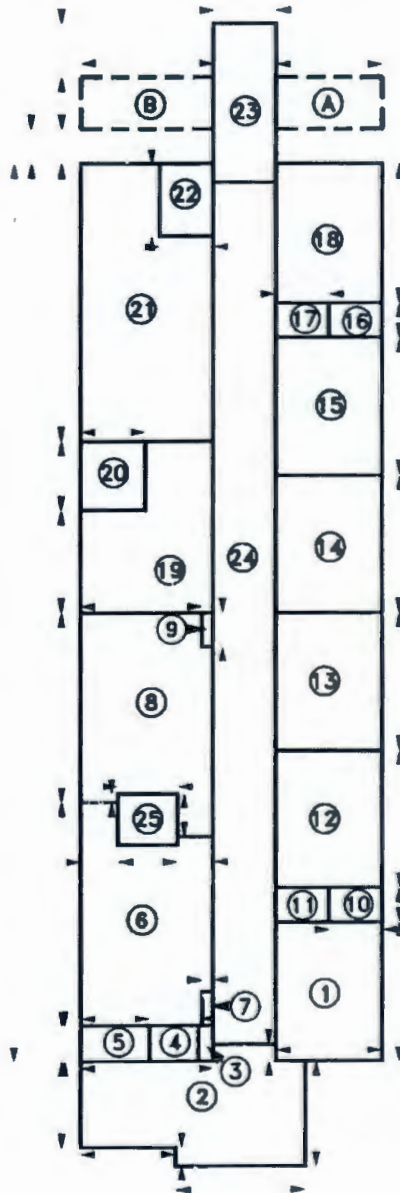

Not drawn to scale

216 - King Estates Middle School - Unit B

8251 Fontaine Street - Oakland, CA 94605-4109

THINK

2011



OAKLAND UNIFIED
SCHOOL DISTRICT

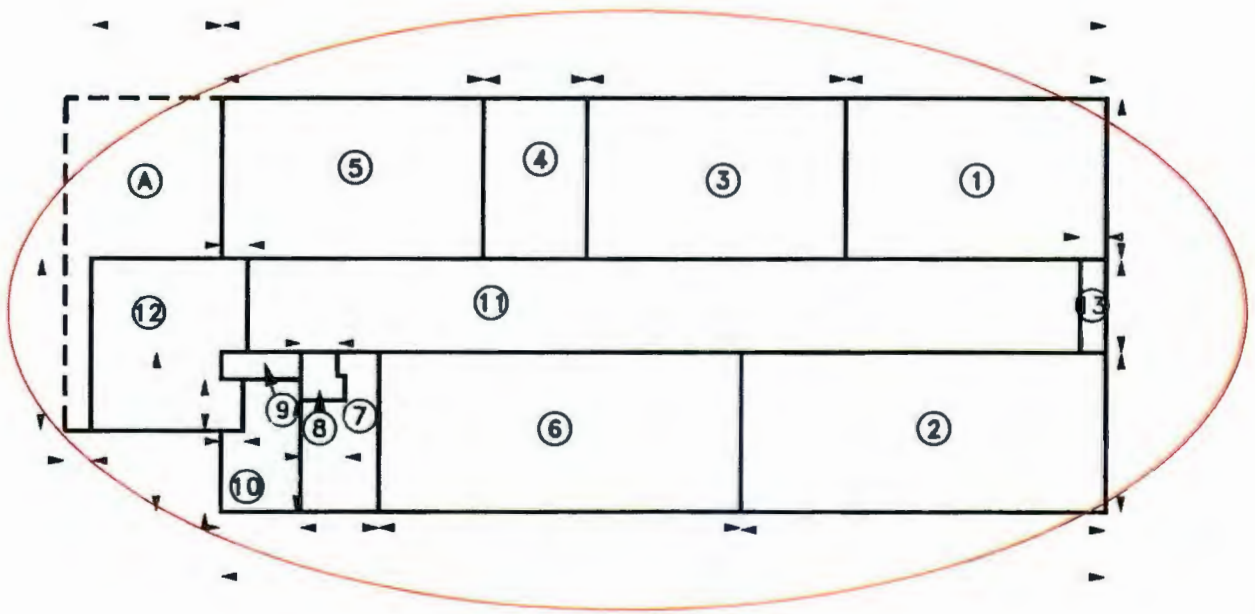

Not drawn to scale



216 - King Estates Middle School - Unit C

8251 Fontaine Street - Oakland, CA 94605-4109

THINK

2011



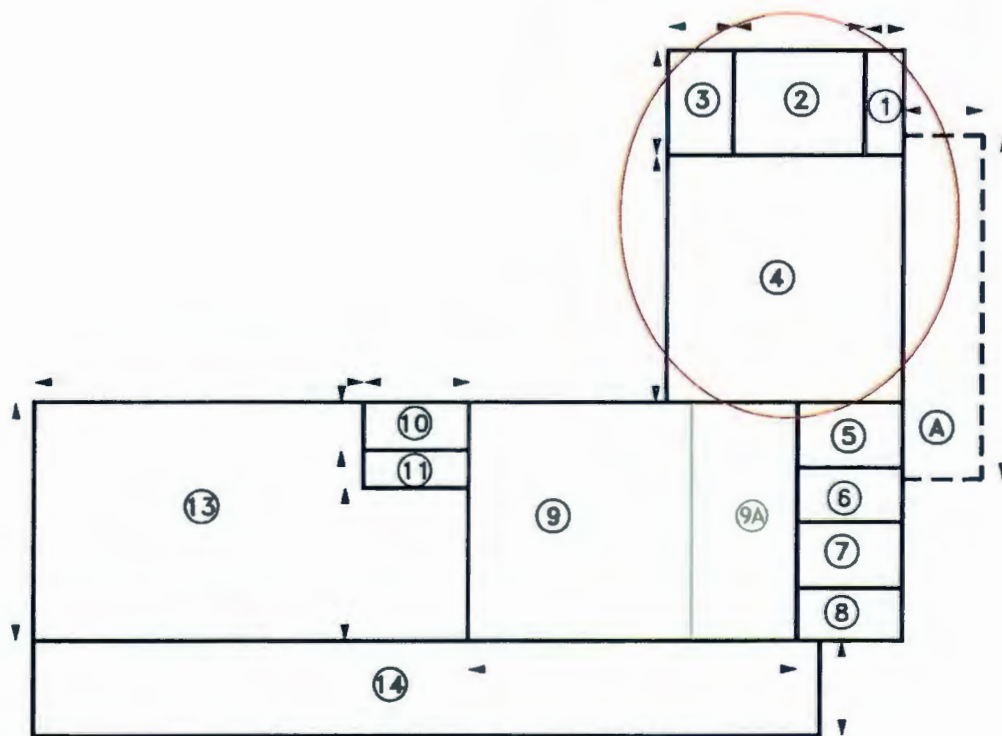

Not drawn to scale



216 - King Estates Middle School - Unit D

8251 Fontaine Street - Oakland, CA 94605-4109

THINK

2011



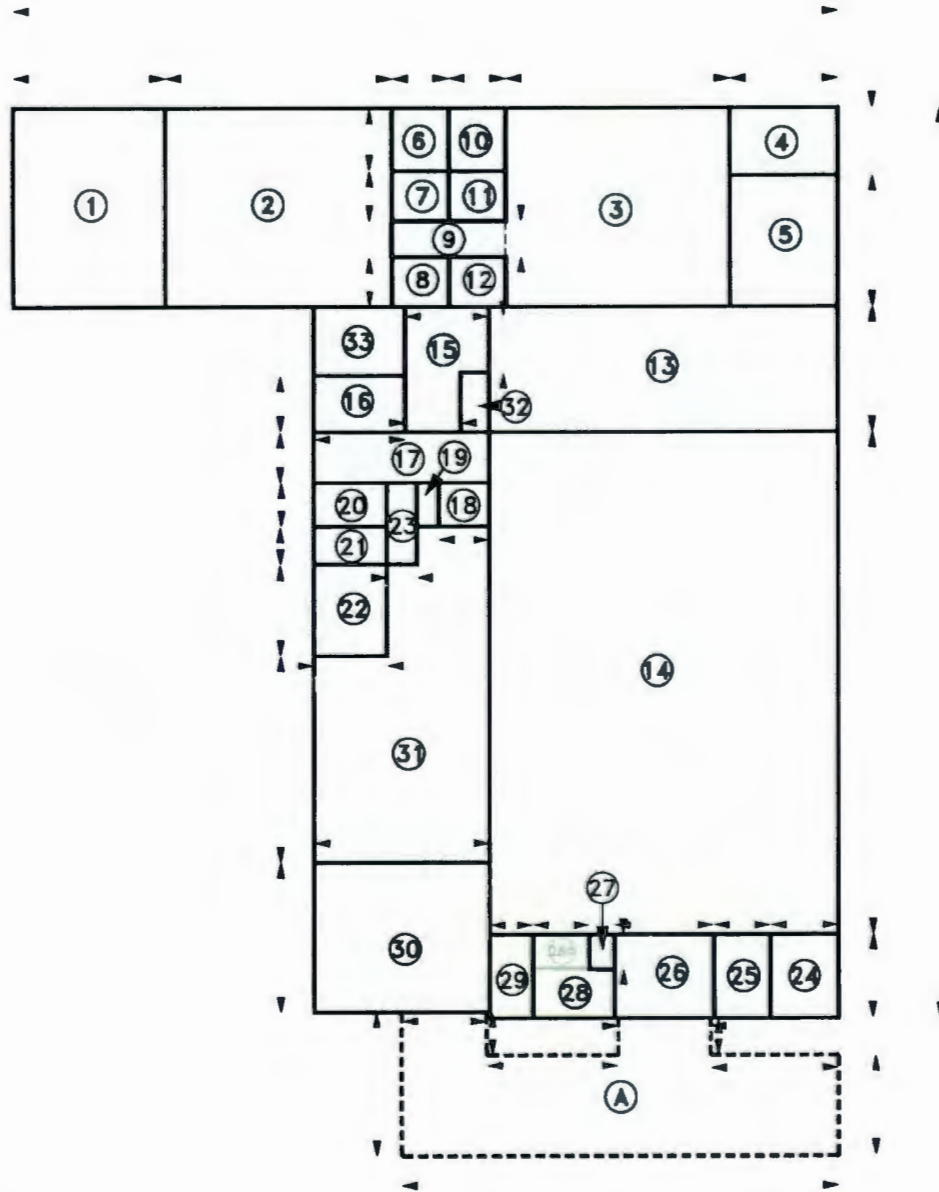

Not drawn to scale

216 - King Estates Middle School - Unit E

8251 Fontaine Street - Oakland, CA 94605-4109

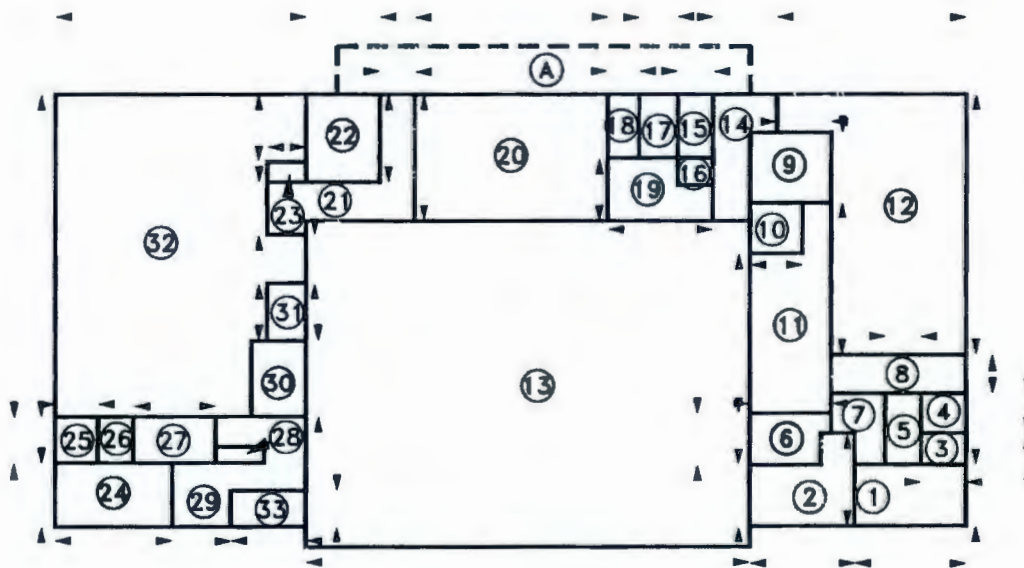

Not drawn to scale



216 - King Estates Middle School - Unit F
 8251 Fontaine Street - Oakland, CA 94605-4109

THINK

2011



**Exhibit C: Guide for Charter Schools in
Oakland Unified School District Facilities
2012-2013**



Guide for Charter Schools in Oakland Unified School District Facilities 2012-2013

Important Contact Information:

- OUSD Buildings & Grounds: 955 High Street Oakland, CA 94601
Phone: (510) 879-8397 Fax: (510) 879-8393
- OUSD Office of Charter Schools: 4551 Steele Street, Main Building, Rm. 11, Oakland, CA 94619
Phone: (510) 336-7500 ext. 1 Fax: TBD



Buildings & Grounds Work Order Protocol

Please note: work orders are to be placed by designated Site Staff only. Please designate a minimum number of staff responsible for placing work orders so as to minimize confusion and the opportunity for miscommunication.

1. Contact work control center at (510) 879-8400 with the following information:
 - a. Site Name (Site Number if applicable)
 - b. Contact Name and Phone Number
 - c. Exact nature of request (i.e. 2 light fixtures broken/missing in room 2 Main Building vs. replace light fixtures) – Please specify if EMERGENCY
 - d. Specific location (Building/Room Number/Area)
 - e. Obtain your Work Order number; this is critical for tracking your order

Work Control Hours are Monday through Friday, 7:30am – 4:00pm

1. If there is an emergency and there is no answer, contact the Main Office: (510) 879-8397.
2. If it is after hours (for emergency only), contact On-Call Manager: (510) 277-7284.

The Work Control Center has the responsibility of evaluating and assigning a priority level to all work requests. General Priority Levels and Time Lines are as follows¹:

1. Emergency Requests: same day response whenever possible or next business day, depending on nature of problem and time received.
 - Emergencies consist of repairs/replacements that need to be addressed immediately in order to protect the health and safety of a student, employee or other person at the site and/or prevent damage to the integrity of the site.
2. Non-emergency requests that require immediate attention, but do not require same day service completed within 1-7 business days.
 - Requests of a general nature that do not pose an immediate threat to the safety of the facility or its occupants to be completed within 10-30 business days.
 - If you have placed a work order and the request has not been addressed within the allotted timeframe, please follow up with the Work Control Center at (510) 879-8400. Have your work order number and date of request.



For pest management and custodial requests contact Custodial Services at (510) 879-8352.



For environmental concerns contact Risk Management at (510) 879-8588.

¹ See Buildings & Ground Prioritization List for more detail.



Facility Task Responsibility Matrix

Below is a comprehensive list of facilities tasks that may arise at your site. The responsibility for each task, whether District or charter school, has been established by the facilities department as a baseline. Each charter school’s specific Facility Use Agreement dictates the ultimate responsible party, and if the Agreement is not in alignment with the below matrix, the Agreement shall trump the matrix.

Task	Charter School	OUSD
1. Broken lock replacement/repair	repair ³	replacement
2. Broken window replacement	X	
3. Broken toilet replacement/repair	repair	replacement
4. Broken sink replacement/repair	repair	replacement
5. Painting exterior/interior of the campus	X	
6. Replacement/repair of broken skylights	repair	replacement
7. Replacement/repairs of broken kitchen equipment (capital equipment such as stoves, ovens, refrigerators)	X	
8. Repair of heaters		X
9. Repair/replacement of window blinds	X	
10. Repair/replacement/upgrade of phone system	X	
11. Repair/replacement/upgrade of security system		X
12. Replacement of broken floor tiles		X
13. Replacement of broken ceiling tiles		X
14. Repair of broken electrical outlets	X	
15. Repair of broken white boards/chalk boards	X	
16. Asphalt repair	routine ⁴	non-routine
17. Fence repair	X	
18. Sidewalk repair in front of and around school exterior		X
19. Replacement of light fixtures (not ballasts or bulbs)		X
20. Replacement of baseboards	X	
21. Repair of water damage		X
22. Repair/replacement of roofs		X
23. Pest management	X	
24. Repair/replacement of doors (interior and exterior)	repair	replacement
25. Repair/replacement of door push bars	repair	replacement
26. Repair of internet cabling/jacks/conduits	cabling, jacks	conduits
27. Repair of gates	repair	replacement
28. Repair/replacement of towel and soap fixtures in bathrooms	X	
29. Replacement of broken mirrors	X	
30. Repair of water fountains	X	
31. Repair of broken wooden cabinets and shelves	X	

³ Where “repair” and “replacement” are cited, this notes a distinction in responsibility. For many tasks, a repair is the responsibility of the charter school, while replacement is the responsibility of the district.

⁴ A distinction of whether a repair is routine or non-routine may be easily made. When it is not, consultation with District facilities staff may be necessary.



EXHIBIT D

Fees, Allocation, and Payment Schedule

Total Square Footage at Site	85,969
Charter School Dedicated Space plus Proportion of Shared Spaces	20,540
% of Site Use (based on teaching stations)	32%

Pro Rata Charge for 2012-2013

Fee per square foot: \$2.95

Total chargeable square footage (above): 20,540

Total charge to Charter School: \$60,593

Utilities

% of Site Use: 32%

Custodial Services

% of Site Use: 32%

Payment Schedule

25% by October 1

25% by December 1

25% by April 1

25% by July 1



OFFICE OF CHARTER SCHOOLS

Priority Level 3 - Requests of a general nature that do not pose an immediate threat to the safety of the facility or its occupants. Requests to be completed within 10-30 business days.

- Light bulbs (5 or less)
- Missing tiles (ceiling/floor)
- Signage
- Broken windows (2nd floor)
- Furniture/fixture repair
- Security lights (3 or more)

Priority Level 4 - Deferred Maintenance/Improvement Services. Improvement requests take precedence over existing Facility small projects, additions, modifications and all work requests not associated with a repair of the facility. All work requests assigned a Level 4 Priority will be reviewed on a case-by-case basis and discussed with the appropriate parties for items such as funding, feasibility and timeline for completion.

- Chalkboards
- Pin boards
- Partition walls
- Cabinetry
- Landscaping
- Enhancement painting
- Fencing additions
- Electrical additions (i.e. computer lab)



Buildings & Grounds Prioritization of Work Orders

The Work Control Center has the responsibility of evaluating and assigning a priority level to all work requests received². The Priority Levels and Time Lines are as follows:

Priority Level 1 - Emergency Requests – Repairs that pose a health and safety concern and require immediate attention. Same day response whenever possible or next business day, depending on nature of problem and time received.

- Gas & Water Leaks (non-roofing)
- Power Shortage
- Hazards
- Sewer backups
- Graphic graffiti
- Floods
- Gain entries
- Elevator malfunction; trapped in shaft
- No Heat (entire bldg)/ No Ventilation – Priority Order: 1) CDC, 2) Elementary, 3) Middle, 4) High, 5) Admin/Adult Ed
- Missing storm drain cover
- Playground equipment
- Communication/Clocks/Bells
- Fallen Trees/Branches
- Personnel locked-in building
- Vandalized Toilet Fixtures

Priority Level 2 - Non-emergency requests – Repairs that require immediate attention, but do not require same day service. Requests to be completed within 1-7 business days.

- General graffiti
- Ramp repair
- Drinking fountain
- Urinal/toilet backup
- Potholes
- Roof leaks
- Broken windows/doors/hardware/restroom accessories
- Fence repair
- Re-keying/replacement of keys
- Intrusion/fire alarm repair
- Light bulbs (5 or more)
- No Heat (specific rooms) –Priority Order: 1)CDC 2)Elementary 3)Middle 4)High 5)Admin/Adult Ed
- Thermostat Adjustment

² Please note that the prioritization list governs work orders for both district and charter schools. In some cases, the items listed may be the responsibility of the charter school. Refer to the Responsibility Matrix and your Facility Use Agreement for more information.