



**OAKLAND UNIFIED  
SCHOOL DISTRICT**  
*Community Schools, Thriving Students*

**DRAFT**

[www.ousd.k12.us/facilities](http://www.ousd.k12.us/facilities)

Produced January 2015



Central Commissary at Foster Project Rendering

## Measure J & B Independent Citizens' Bond Oversight Committee

# Annual Report 2013-2014

# About Measure J & B

## BOND BACKGROUND

In June 2012, Oakland voters passed Measure J, a \$475 million School Facilities Improvement Bond, for Oakland Unified School District to enhance the educational environment for the students and communities of Oakland. In year 3 of the Bond Program, planning and construction progressed at many sites throughout the District.

This annual report summarizes and highlights the work of the Independent Citizens' Bond Oversight Committee (CBOC) and reviews the expenditures in the Measure J and Measure B School Facilities Improvement Bond for the fiscal year 2013-2014.

## MEASURE J PROJECTS

The legal guidelines for spending Measure J funds require that the district restrict expenditures to those projects described in the Bond project list. Since the passage of Measure J, the Board of Education has approved 21 projects with a total value of \$475 million.

Measure J and B provided funding for Modernization and New Construction projects that included:

- Grade Expansions
- Central Commissary
- Finishing Kitchens
- Student Restroom Renovations
- Digital Technology Upgrades
- Libraries
- Multi-purpose rooms
- Cafeterias
- Wellness/Health/Youth Centers
- Child Development Centers
- Fire Alarm/Intrusion alarm replacements
- Playground and athletic field improvements
- California Solar Panel Initiative Installations

## PROJECT DISTRIBUTION ACROSS THE DISTRICT—FISCAL YEAR 2013-2014

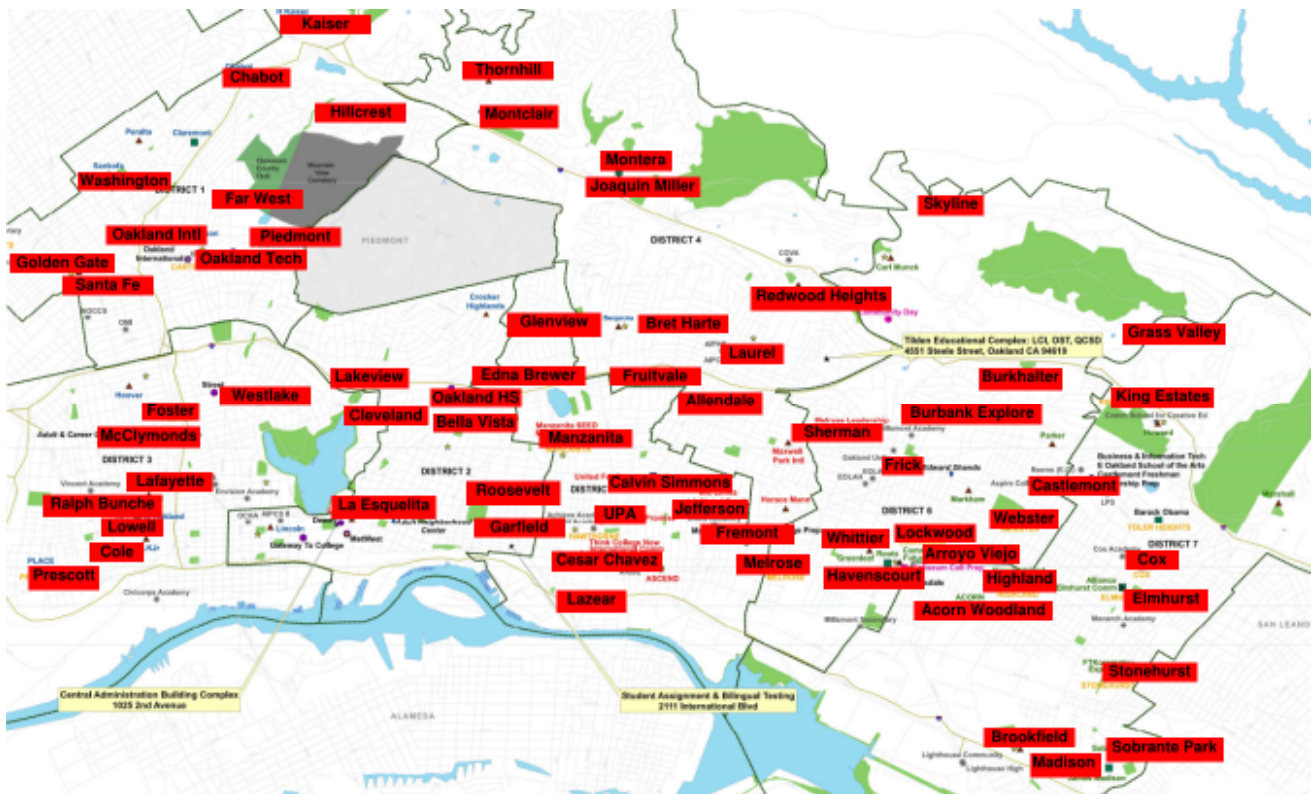

# Measure J & B Dollars at Work

## 2014 LOCAL BUSINESS UTILIZATION HIGHLIGHTS

In January 2014, the Board of Education amended the Local Business Program (circa 2008) to increase the Local Business Utilization (LBU) for the District's Capital Program from 20% to 50% requirement on each contract. The Board amendment to the Local Program further increased the amount of Oakland voter-approved bond funds spent with Oakland businesses. By the end of December 2014, the District reached a milestone with an overall Local Business Utilization of 50% of the Capital Program of \$289 million spent.

All of Facilities projects awarded using the Lease-Leaseback negotiated procurement process exceeded the 50% Local Business Utilization. The following are several Lease-Leaseback projects that did exceedingly well:

<i>LLB Project Name</i>	Havenscourt MS	La Escuelita Phase 2	Lowell MS
<i>Project Total</i>	\$13M	\$35M	\$13.7M
<i>LBU (in \$)</i>	\$9.1M	\$22.5M	\$10M
<i>LBU (in %)</i>	70.8%	64%	74%

## LEVERAGING MEASURE J & B FUNDS

OUSD continues to use available opportunities to leverage the \$435 million Measure B Bond. For instance, the District, in conjunction with the local community, obtained Urban Forestry and Air Resource Quality grants from the State and Youth / Family Center grants from the City. In addition to State and Local grant funding, the District has taken advantage of subsidized interest rates offered by the Federal government through financial instruments such as Quality School Construction Bonds (QSCB) and Clean & Renewable Energy Bonds (CREB). To date, the District has applied for approximately \$105,309,688, and has received \$76,495,167, in grants and matching funds. The District continues to aggressively explore new opportunities to leverage Measure B funds.

## SUSTAINABILITY AND CHPS

The District's robust green building sustainability initiative requires that all design and construction projects meet its High Performance Schools Guidelines. There is a focus on maximizing natural daylighting, conserving energy, conserving water, resource efficiency, and superior indoor environmental quality among other sustainable attributes. The Bond Program utilizes the latest CHPS (Collaborative for High Performance Schools) Criteria (currently CA-CHPS v.2009) in all elements of design and construction of Modernization and New Building projects. The La Escuelita Education Center, Phase One earned CHPS Leader Verified which is currently among the highest number of points awarded in the State. Moreover, the La Escuelita Education Center was designed to be the District's first zero net energy (ZNE) school campus, with a combined Phase 1 and 2 solar photovoltaic system of approximately 600 kW.

Other ongoing OUSD High Performance Schools include projects at: Montclair Elementary, Havenscourt Middle School, Washington (Sankofa Academy) Elementary, and La Escuelita Education Center Phase 2.

## DISTRICT VISION, PRIORITIES, & GOAL

### The Vision

OUSD's vision is to support academic achievements and re-establish schools as centers of the community by transforming OUSD into a full-service community school district. In this model, high quality instruction, health and physical education, nutrition, medical, dental, recreation, housing, employment, and language instruction are all provided at the school, which becomes the hub of community activity. The emphasis is on educating and caring for the whole child. Social and human services are not seen as extras or add-ons in these schools. Instead, collaboration centered on the well-being of children and families drive all programs at these schools.

### The Priorities

OUSD's priorities are:

- Safe healthy, and supportive schools
- High quality, effective instruction
- College and career readiness

### The Goal

OUSD's goal is to build a Full-Service Community School District that cares for the whole child, eliminates inequity, and provides all students with excellent teachers every day.

# Building a Better Community

## COMPLETED PROJECTS HIGHLIGHTS

### ROOFING PROJECTS

The roofing projects completed this past summer included roof repairs at Rudsdale, Thornhill and Melrose Elementary. Work included removal of existing gutters, downspouts through-out, including replacing the ductwork for the existing HVAC systems and related electrical conduits on the new roofs.



Thornhill ES Roofing Replacement Project

### ELMHURST PAVING

The Elmhurst Paving project included replacement of existing asphalt at parking lots and playgrounds including new striping for parking lots, playgrounds and the basketball court.



Elmhurst MS Paving Project

### CALIFORNIA SOLAR INITIATIVE (CSI) PROJECTS

The California Solar Initiative project is a solar rebate program through Pacific Gas and Electric. The project includes the installation of photo-voltaic panels at 17 different school sites, spread across the entire school district. Several sites will receive new roofing, while others will receive parking shade structures to house the solar panels. Construction of the 16 out of 17 individual sites are complete. The 17 sites include:

- ◆ Bret Harte MS
- ◆ Oakland International HS @ Carter
- ◆ Castlemont HS
- ◆ Edna Brewer MS
- ◆ Havenscourt MS
- ◆ King Estates MS
- ◆ Lowell MS
- ◆ Madison MS
- ◆ McClymonds HS
- ◆ Montera MS
- ◆ Oakland HS
- ◆ Oakland Tech HS
- ◆ Roosevelt MS
- ◆ Sankofa/Washington ES School
- ◆ Skyline HS
- ◆ Westlake HS
- ◆ Joaquin Miller ES



Oakland High School CSI Project

# Building a Better Community

## UPCOMING PROJECTS IN DESIGN

### Central Commissary at Foster

The Central Commissary project will be the state-of-the-art green facility and a model for the nation that brings innovation of integrating school food and education. The project includes a Central Commissary (40,000 sf), an Administration Building (10,000 sf) and Education Center (5,000 sf) that features a 1.5 acre urban farm, including an outdoor dining and kitchen area that will accommodate 120 persons.

The Central Kitchen will serve as the new district-wide school food system network that connects nutrition, education and community programs at OUSD's satellite kitchens, school community kitchens, school gardens and produce market stands. The Central kitchen will prepare student meals for delivery to 80 plus schools throughout the District, to house food storage, food freezers and coolers, areas for food preparation, bakery, production office, warehouse, janitorial and laundry.

The Education Center features a demonstration/teaching kitchen, a general education classroom, a training classroom, faculty workstations, student lockers and student restrooms. The education center will be used for a variety of programs: career pathways (linked learning), professional development and community education. The educational aspect of the Central Kitchen will also include an Instructional Farm: The instructional farm comprises 1.5 acres and is designed to showcase a wide variety of hand-scale agricultural techniques, growing methods and crops. Interpretive signage and artwork will be included to communicate key ideas and build a sense of place. Project is currently slated to begin work in Summer of 2015.

### Finishing Kitchens

As part of the Foster Central Commissary model the finishing kitchens are designed to prepare meals from bulk ingredients delivered by the new Central Commissary. Currently each existing kitchen serves pre-packaged hot food delivered to the school. This new design will allow students the opportunity to have fresh prepared meals onsite. The project includes a fully equipped kitchen addition (970 SF) containing a servicing line, cooking oven, dry goods storage, tray wash area, food preparation area, staff restroom and custodial closet. Hot food will be prepared, cooked and served in the new kitchen and includes a full-service salad bar, fresh fruit, milk coolers and a hydration station.



Foster Central Commissary Rendering  
Indoor and Outdoor Spaces Invite Students to Learn



Foster Central Commissary Rendering  
View of Urban Farm Looking Back to Education Center

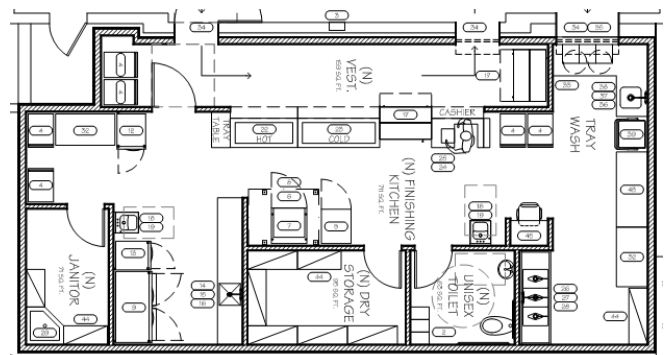

Finishing Kitchen Floor Plan

# Building a Better Community

## UPCOMING PROJECTS IN DESIGN

### Glenview Elementary New Construction Project

The Glenview Elementary School New Construction project scope includes a new 52,000 SF two-story building with a partial basement that will replace the existing structures. The new building will include a lobby, administrative and student support offices and meeting rooms, a library and a multi-use room with a stage, kitchen and storage. The new building will be constructed to be designed to be grid neutral incorporating rooftop PV panels. The existing two story facade section and porch feature which is to be retained will be incorporated into the new building structure and related site work improvements.



Existing Glenview Elementary Front Entrance Façade to be Retained

### Whittier Elementary Expansion Project

The expansion project at Whittier includes construction of a new two-story addition, a multipurpose building, a flex classroom building and four new modular kindergarten rooms. The existing three level classroom building will include seismic improvements and upgrades to the heating system, plumbing, lighting and interior finishes.



Whittier ES Expansion Project Rendering

### Fire Alarm Upgrade Projects

An ongoing safe environment for all students is an OUSD priority. The District continues to improve infrastructure systems such as fire and intrusion alarm systems. Currently under the Measure J Bond program, there are 7 fire alarm and intrusion upgrade projects in design and slated to begin



# CBOC Roles & Activities

## PURPOSE AND DUTIES OF THE CBOC

As required by Education Code Section 15278, the District appointed a Committee of local residents, whose main charge is to inform the public about how the Bond money is being spent. The Committee actively reviews and reports on the expenditure of taxpayer's money for school construction to ensure that bond funds are spent in accordance with the provisions of the bond. The Committee is comprised of up to 8 appointees, including a chairperson and secretary.

### Committee Members for the 2013-2014 Fiscal Year

Chair	Renee Swayne
Vice Chair	Andrea Dawson
Secretary	Lisa Young
Member	Patricia Williams
Member	Patricia Centeno
Member	Jean Moore
Member	Christopher Vernon
Member	George Holland

**"Thankfully, the people of Oakland understand that students are more likely to prosper when their environment is conducive to learning. By passing the bond measures the community has insured that the District can continue to build new and renovate existing school buildings. This sends a powerful message to kids and shows the importance their community places on education."**

**- Lisa Young, CBOC Secretary**

## CBOC ACTIVITIES

The Committee convened and participated in a number of key activities such as preparing the Annual Report, reviewing program expenditures, and visiting project sites to observe construction progress.

### Following is a list of Project Site Visits for 2013-2014 Fiscal Year:

#### February 7, 2014

Roosevelt MS California Solar Initiative (CSI)  
Glenview ES Portable Replacement

#### March 7, 2014

Foster ES, Central Commissary  
Bret Harte MS California Solar Initiative (CSI)

#### April 4, 2014

Oakland Int'l HS California Solar Initiative (CSI)  
Whittier Expansion Project

#### May 2, 2014

Havenscourt MS California Solar Initiative (CSI)  
LEEC Phase 2 New Construction

#### June 6, 2014

Sankofa ES California Solar Initiative (CSI)  
Sankofa ES Expansion Project

**"I have learned that every site in OUSD is unique. The facilities staff is great at identifying the needs and challenges of each site and then planning and providing safe and modern facilities that support our students' development and success."**

**- Pat Williams, CBOC Member**

*Note:*

*CDC = Child Development Center*

*ES = Elementary School*

*MS = Middle School*

*HS = High School*

# Audit Review and Findings

## ANNUAL EXPENDITURE REVIEW

Of all the activities undertaken by the CBOC, its primary duty is to review and ensure that the Measure J & B funds are spent in accordance with the Bond language. The chart at the end of this report reflects a summary of project expenditures for the Fiscal Year Ended June 30, 2014. The report is organized to reflect the life of each project commencing with the Pre-Design Phase and concluding with the Completed Phase. In addition, \$8,884,908 was expended on program support items such as staff and consultants in direct support of the bond program. The combined project and program expenditure for the 2013/2014 Fiscal Year totaled 20,626,307, and the cumulative expenditures for the first seven years of the bond program totaled \$360,798,880 through June 30, 2014.

The Bond Issuances for the 2013/2014 Fiscal Year, each on March 21, 2013, were:

- *Election 2006, Series 2012A; amount \$31,040,000, maturity date is August 1, 2032*
- *Election 2006, Series 2012B, Qualified School Construction Board; amount \$23,960,000, maturity date is August 1, 2033*

## FINANCIAL AND PERFORMANCE AUDIT

As required by Measure B, each fiscal year a financial and performance audit of Measure B expenditures is conducted. Yano Accountancy Corporation conducted the Financial and Performance Audits of Measure B Revenues and Expenditures for the year ending June 30, 2013.

The Financial Audit included a review of the financial schedule presented by the District and found that the financial schedule presents Measure B revenues and expenditures for the fiscal year ending June 30, 2013. The Financial Audit included the following findings and responses from the District Management:

- *Finding 2013-01: The audit found that credits to expenditures did not have adequate support. OUSD responded that recommended adjustments have been made to correct this finding.*
- *Finding 2013-02: The audit found that some construction contract invoices were not processed within 30 days of submission. OUSD management says progress has been made and they continue to work to address this finding and pledge to have it corrected before the next audit is issued.*

The Performance Audit evaluated the District's compliance in ensuring all proceeds were spent on bond-approved projects and implementing internal controls. Based on the evidence obtained from OUSD there is a reasonable basis for the findings and conclusions that bond funds were properly expended and internal controls over compliance were implemented.

## STATEMENT OF COMPLIANCE

The 2013/2014 Measure J & B Annual Report is submitted to the Board of Education by the Committee, in accordance with the Education Code section 15278 (b). The Committee advises that, to the best of its knowledge based on available information provided by the District, OUSD is in compliance with the requirements of Article XXIIA, Section 1(b)(3) of the California Constitution. Specifically, the performance and financial audits were conducted and included a list of bond-approved projects. There were no findings disputing the requirements that all bond proceeds be used on bond-approved projects and that bond proceeds not be used to pay administrator salaries.



### **LOOKING AHEAD (Fiscal Year 2014-2015)**

As we conclude this 2013-2014 annual report, we look forward to the 2014/2015 year. Here are some of next year's scheduled milestones in design and construction:

- Foster Central Commissary
- Glenview ES New Construction
- Finishing Kitchens at Piedmont ES, Laurel ES, Hillcrest ES, and Kaiser ES
- Fremont HS New Construction
- Restroom Renovations at various sites
- Athletic Fields Replacement
- Grade Expansion Projects

### **MEASURE J**

In November 2012, Oakland voters passed Measure J, a \$475 million School Facilities Improvement Bond, for Oakland Unified School District to enhance the educational environment for the students and communities of Oakland. Measure J will provide funding for Modernization and New Construction projects that include:

- Seismic upgrades of schools and classrooms to reduce danger from earthquakes
- Improving energy efficiency
- Repair bathrooms and unsafe playground areas
- Upgrade kitchen facilities to improve nutrition and nutritional education
- California Solar Initiative Project
- Paving Projects

**"In a city where many of the schools were built years ago and where some sites have not had improvements in many years, it is exciting to see how the bond expenditures have improved the educational environment for students in Oakland, even as we realize there is simply not enough money to correct all of the insufficiencies that exist.**

**- Renee Swayne, CBOC Chair**

# Expenditures

Measure B 2013/2014 Fiscal Year		
Site	Project	Expenditures
<b>Projects in Pre-Design</b>		
Burbank (Explore)	Small Schools	
Fremont Federation	Modernization Phase 3	48,804.25
Lakeview CDC	Fire and Intrusion Alarm Replacement	
Laurel Elementary	Intrusion Alarm	3,867.80
Lazear Elementary	Modernization	
Melrose	Small Schools (Bridges)	
Roosevelt Elementary	Modernization	170,621.65
Whittier	New Building	5,830.00
<b>Total Expenditures in Pre-Design</b>		<b>229,123.70</b>
<b>Projects in Design</b>		
Allendale	Allendale Fire Alarm Replacement	3,775.00
Bella Vista Elementary	Fire and Intrusion Alarm Replacement	14,208.00
Burbank Elementary	Fire and Intrusion Alarm Replacement	
Centro Infantil	CDC Fire Alarm Replacement	
Edna Brewer	Fire and Intrusion Alarm Replacement	
Far West High School	Fire and Intrusion Alarm Replacement	
Foster Elementary	Fire Alarm Replacement	
Glenview Elementary	Fire and Intrusion Alarm Replacement	2,778.60
Golden Gate	CDC Fire Alarm Replacement	
Grass Valley CDC	Fire and Intrusion Alarm Replacement	
Hintil	CDC Replacement	
Joaquin Miller	Fire and Intrusion Alarm Replacement	10,555.60
Laurel Elementary	CDC Replacement	151,396.91
Laurel Elementary	Fire Alarm Replacement	
Life Academy	Life Academy Renovation Seismic/Reno	
Manzanita Elementary	CDC Fire Alarm Replacement	4,540.00
McClymonds Small Schools	Small Schools	12,359.70
Santa Fe CDC	Fire and Intrusion Alarm Replacement	1,970.00
Sherman Elementary	Fire and Intrusion Alarm Replacement	
Skyline High School	Auditorium Fire Alarm Replacement	
Washington Small Schools	CDC Fire Alarm Replacement	
Webster Academy	CDC Replacement	
<b>Total Expenditures in Design</b>		<b>201,583.81</b>
<b>Projects in Construction</b>		
Lafayette Elementary	Fire and Intrusion Alarm Replacement	229,996.47
Piedmont Avenue Elem.	Fire and Intrusion Alarm Replacement	283,950.53
La Escuelita Education Center	New Education Center	6,592,739.35
<b>Total Expenditures in Construction</b>		<b>7,106,686.35</b>
<b>Projects in Closeout</b>		
Acorn/Woodland Library	Library	
Arroyo Viejo	CDC Replacement	30,064.75
Arts Far West	Intercom/PA/Clock Repairs	
Bret Harte Middle	Modernization	
Brookfield	Playground	
Burckhalter Elementary School	Portable Installation Project	21,195.00
Calvin Simmons	Improvements and Career Tech Lab	185,219.75
Calvin Simmons	Health Center	
Calvin Simmons	Modernization/Small Schools	
Carter Middle	Modernization	
Castlemont	Auditorium Renovations	
Cesar Chavez Elementary	School Fire Alarm Replacement	
Chabot Elementary	Portable	
Cleveland Elementary	Modernization Phase 2	
Cole Middle School	Renovations	
Cole Middle School	Health Center	
Cole Middle School	Intercom/PA/Clock Repairs	
Cox Elementary	Modernization/ Small Schools	7,834.73
Cox Elementary	Additional Classroom Phase 1	
Cox Elementary	Additional Classroom Phase 2	
Cox Elementary	Additional Classroom Phase 3	
Cox Elementary	Additional classroom Phase 4	7,251.68
Cox Elementary	Additional Classroom Phase 5	
Cox Elementary	Additional Classroom	7,251.68
District-wide	Fire Alarm Maintenance	117,164.11
District-wide	Playground Inspections & Repair	996.00
Edna Brewer	Restroom Renovation	

# Expenditures

*Continued Measure B Expenditures...*

Elmhurst Middle	Modernization/ Small Schools	1,415.22
Elmhurst Middle School	Elmhurst wellness Center	257.60
Emerson Elementary	Modernization	
Frick	Frick Wellness Center	3,643.96
Grass Valley Elementary	Portable Installation Project	27,761.75
Harriet Tubman	CDC Fire Alarm Replacement	3,340.00
Havenscourt Middle	Classroom and Cafeteria	9,195.00
Havenscourt Middle	Health Center	1,425.06
Havenscourt Middle	Modernization	65,959.00
Highland Small Schools	CDC Fire Alarm Replacement	43.65
Highland Small Schools	Fire Alarm Upgrade	
Highland Small Schools	Interim Housing	
Highland Small Schools	Modernization/ Small Schools Phase 1	
Highland Small Schools	Modernization/ Small Schools Phase 2	
Highland Small Schools	Modernization/ Small Schools Phase 3	
Highland Small Schools	Modernization/ Small Schools	-
Highland Small Schools	New Building	97,066.17
Hoover	Modernization	
Jefferson Elementary	CDC Fire Alarm Replacement	5,740.00
Jefferson Elementary	Portable	8,241.09
Joaquin Miller	ADA Accessibility	
King Estates Schools	Fire Alarm Replacement	14,076.08
King Estates Small Schools	Small Schools Phase 1	454.07
King Estates Small Schools	Small Schools Phase 2	
King Estates Small Schools	Small Schools Phase 3	
King Estates Small Schools	Small Schools Phase 4	
King Estates Small Schools	Small Schools	454.07
Lafayette	Intercom/PA/Clock Repairs	
Laurel Elementary	Modernization	
Lincoln Elementary	Portable Replacement	25,967.50
Lockwood	ES Fire and Intursion alarm Replacement	2,600.00
Lockwood CDC	Fire and Intrusion Alarm Replacement	12,808.70
Lowell Middle	Modernization	586,911.36
Lowell Middle	Health Center	1,097.80
Madison Middle	Modernization	6,785.32
Madison Middle	Health Center	
Manzanita Elementary	Modernization	
Manzanita Elementary	Modernization Phase 2	
Manzanita Elementary	Modernization Phase 3	789.41
Manzanita Elementary	Modernization Phase 4	
Manzanita Elementary	Modernization	789.41
McClymonds	McClymonds intercom/PA/clock Repairs	
Montclair	New Classroom	649,400.59
Montera	Modernization	8,274.64
Montera	Fire Alarm	
Oakland High	Building G Restroom project	10,016.42
Oakland High	Health Center	2,619.94
Oakland High	Williams Settlement	
Oakland Tech	Retro Commissing Project	
Oakland Tech	Oakland Tech Modernization	3,272.57
Peralta	Modernization	
Piedmont	CDC Fire Alarm Replacement	3,420.00
Piedmont	Portable Library	80,587.78
Prescott Small Schools	Small Schools (PLACE)	24,131.78
Prescott Small Schools	Mod	
Ralph Bunche	Modernization	
Redwood Heights	ES Fire Alarm Replacement	
Redwood Heights Portable	Portable addition	
Roosevelt	ES Fire Alarm Replacement	
Roosevelt Middle School	Health Center	
Sequoia	Sequoia Portable Installation	
Skyline High School	Skyline HS Wellness Center	
Sobrante Park	Modernization	6,879.06
Stonehurst	CDC Replacement	14,013.25
Stonehurst	Restroom Renovation	
Stonehurst	Small Schools (Esperanza)	
Urban Promise Academy	Multi-purpose Gym	
Washington Small Schools	Small Schools (Sankofa)	43,522.38
Webster Academy	Kitchen Renovation	4,480.00
Webster Academy	Portable Demolition	
Westlake	Modernization	

# Expenditures

Measure J 2013/2014 Fiscal Year		
Site	Project	Expenditures
<b>Projects in Pre-Design</b>		
Fruitvale ES	Paving and Infrastructure	
Franklin ES	Paving and Infrastructure	
Oakland Tech	Paving and Infrastructure	
Skyline HS	Paving and Infrastructure	11,008.00
Fruitvale ES	Restroom Renovation	
Sobrante Park ES	Restroom Renovation	
Elmhurst MS	Restroom Renovation	
Far West, Roosevelt, Piedmont	Restroom Renovation	
Webster and Lockwood	Restroom Renovation	
Allendale, Garfield, Maxwell Park and Parker	Restroom Renovation	
Hillcrest ES	Finishing Kitchen	
Kaiser ES	Finishing Kitchen	
Laurel ES	Finishing Kitchen	
Piedmont Ave ES	Finishing Kitchen	
Multiple Sites	Restroom Renovation	8,043.46
Burbank ES	Site Improvements	
<b>Total Expenditures in Pre-Design</b>		<b>19,051.46</b>
<b>Projects in Design</b>		
Fremont HS	Replacement	-
Foster ES	Central Commissary	580,098.52
Glenview ES	Renovation or Replacement	52,976.24
Madison MS	Expansion Project	
Oakland International HS	Turf Replacement	-
Various Schools	Portable Demolition	-
Whittier ES	Expansion Project	190,656.00
Washington ES	Expansion Project	69,779.60
Various Schools	Prop 39 Projects	-
<b>Total Expenditures in Design</b>		<b>893,510.36</b>
<b>Projects in Construction</b>		
900/955 High Street	Paving and Infrastructure	149,722.79
Various Schools	California Solar Initiative (CSI) Project	7,542,192.38
Various Schools	Technology Projects	449,449.49
Elmhurst MS	Paving and Infrastructure	108,409.39
		<b>8,249,774.05</b>
<b>Projects in Closeout</b>		
Rudsdale ES	Roofing Project	33,102.99
Thornhill ES	Roofing Project	42,306.71
Melrose ES	Roofing Project	35,644.39
<b>Total Expenditures in Closeout</b>		<b>111,054.09</b>
<b>Total of Measure J Expenditures</b>		<b>9,273,389.96</b>
<b>Total of Measure J &amp; B Expenditures 2013/2014 Fiscal Year</b>		<b>29,908,192.79</b>